

ORDINANCE 17,676

AN ORDINANCE AMENDING APPENDIX A THE UNIFIED DEVELOPMENT CODE OF THE CITY OF PEORIA RELATING TO HANDICAP ACCESSIBLE PARKING

WHEREAS, the City of Peoria is a home rule municipality pursuant to Article VII, Section 6, of the Illinois Constitution of 1970; and

WHEREAS, as a home rule municipality, the City may exercise any power and perform any function pertaining to its government and affairs including zoning regulations and uses; and

WHEREAS, the City of Peoria desires to amend Appendix A, the Unified Development Code;

NOW, AND THEREFORE, BE IT ORDAINED BY THE CITY COUNCIL OF THE CITY OF PEORIA, ILLINOIS AS FOLLOWS:

Section 1: Appendix A of the Peoria City Code, being Ordinance No. 17,403 as adopted on October 11, 2016, is hereby amended by deleting the following stricken words and adding the following underlined words:

8.0 GENERAL DEVELOPMENT STANDARDS

8.1 OFF STREET LOADING AND PARKING

8.1.5 Off-Street Parking General Requirements

E. Handicapped Accessible Parking

1. Any required parking area shall provide parking spaces designated and located to adequately accommodate the disabled, and these shall be clearly marked as such.
2. Markings shall include yellow striping on the pavement designated as the accessible parking space and shall provide a clearly posted sign as provided by Section 11-301 of the Illinois Vehicle Code. Signs shall be vertically mounted on a post or wall at front center of the parking space, no more than 6 feet horizontally from the front of the parking space and set a minimum of 5 feet and a maximum of 9 feet from the finished grade to the bottom of the R7-8 sign. Signage shall clearly announce the fine for illegal parking in the accessible space as \$350.00.
3. Handicapped accessible parking spaces shall be designated nearest the accessible entrance (exit) to the facility. For the first 25 (or less) parking stalls required on a site, one shall be a handicapped accessible space. When more than 25 stalls are required, handicapped accessible parking shall be provided at the rates indicated in the 8.1.6. Such schedule of handicapped accessible parking rates shall be applicable to all districts.
4. Each stall shall be 16 feet in width, including either an eight-foot or five-foot diagonally striped access aisle, by 18½ feet in length. The access aisle can be located on either side of the vehicle portion of the accessible space. Two parking space may share a common access aisle. Diagonal parking spaces shall not share an access aisle. Access aisles serving diagonal parking spaces must be located on the passenger side of the vehicle space. Any adjacent accessible parking space shall not share a common access aisle and nNo ramp shall be located within an access aisle. The aisle shall be kept free from any and all

obstructions at all time. This shall include a prohibition against parking in the access aisle.

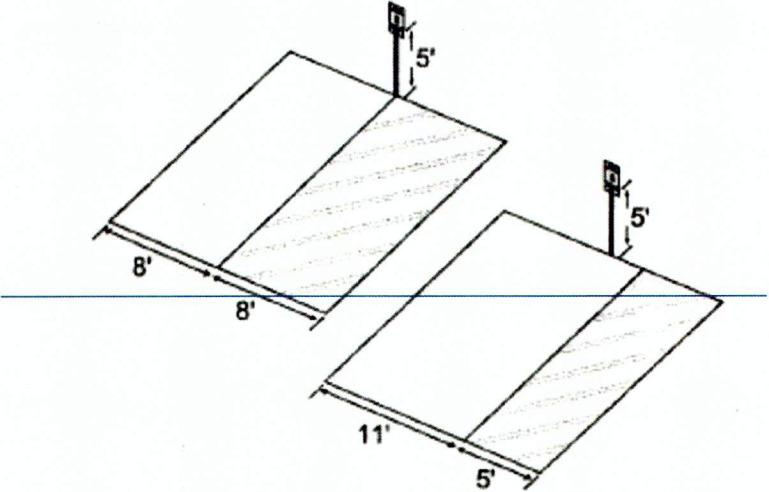

Above: Illustration of two examples of legal accessible parking spaces.

Figure 1

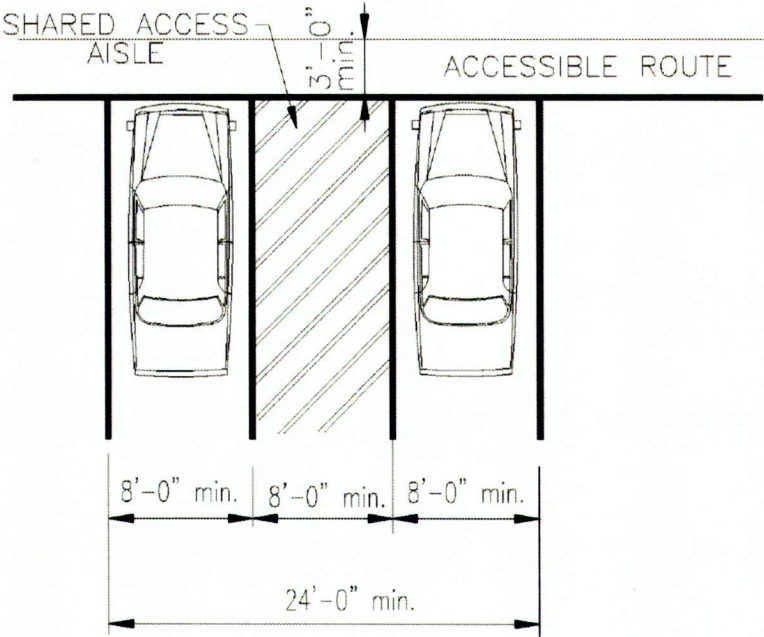

Figure 2

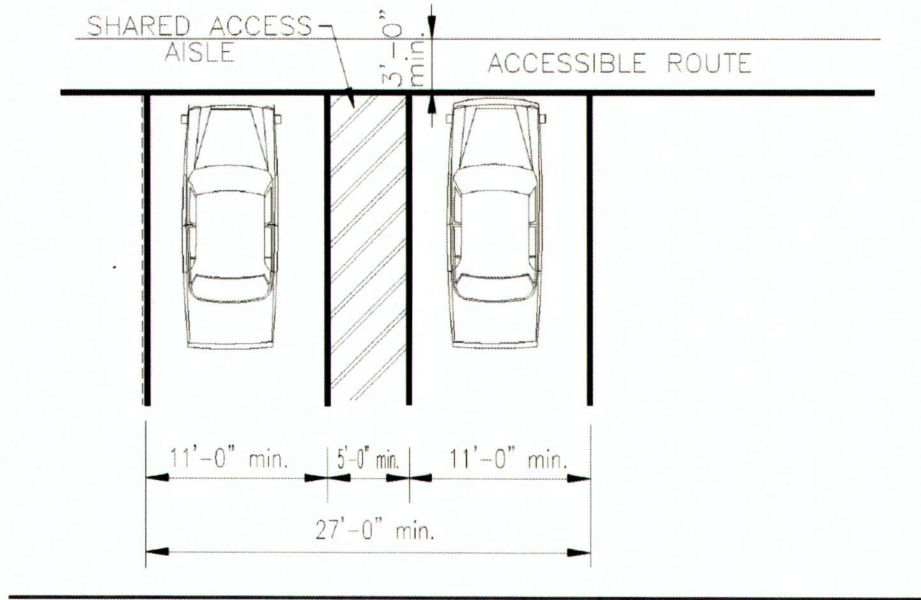
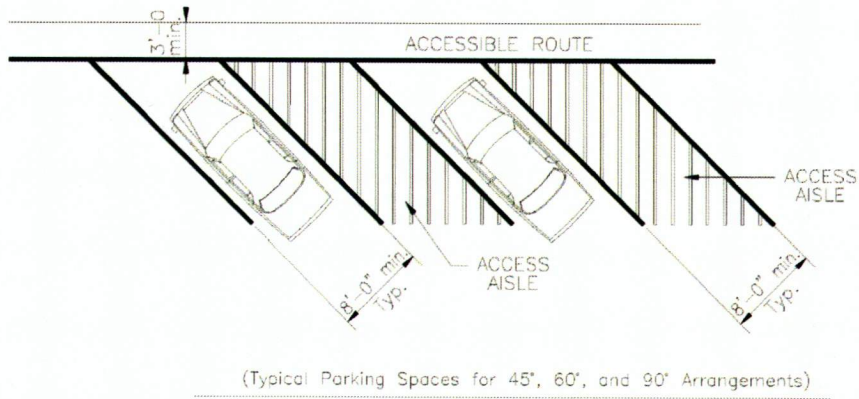

Figure 3



5. Slopes related to accessible parking spaces and access aisles shall not exceed a 1:50 ratio (two percent) in any direction. Exceptions may be granted for unusual terrain conditions. The Zoning Administrator shall have sole discretion to determine the existence of such unusual terrain conditions.
6. Ramps shall be constructed of slip-resistant material with hazardous warning texture and any adjacent sidewalk shall provide a width of unobstructed sidewalk space of at least 36 inches, including any ramp encroachment. The designation of handicapped accessible parking stalls shall constitute consent by the property owner to the enforcement of the restriction of such spaces to disabled motorists by the City.

Section 2. This Ordinance shall be in full force immediately and upon passage and approval according to law.

PASSED BY THE CITY COUNCIL OF THE CITY OF PEORIA, ILLINOIS, THIS

23rd DAY OF April, 2019

APPROVED:

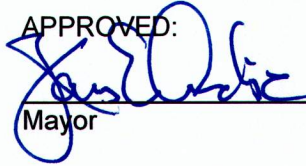

Mayor

ATTEST:



City Clerk

EXAMINED AND APPROVED:



Corporation Counsel