

ORDINANCE NO. 17,249

**ORDINANCE AMENDING APPENDIX C OF THE CODE OF THE CITY OF PEORIA
RELATING TO PARKING REQUIREMENTS**

WHEREAS, the City of Peoria is a home rule municipality pursuant to Article VII, Section 6, of the Illinois Constitution of 1970; and

WHEREAS, as a home rule municipality, the City may exercise any power and perform any function pertaining to its government and affairs including zoning regulations and uses; and

BE IT ORDAINED BY THE CITY COUNCIL OF THE CITY OF PEORIA, ILLINOIS AS FOLLOWS:

Section 1: Appendix C of the Peoria City Code, being Ordinance No. 16,121 as adopted on June 12, 2007, and thereafter amended, is hereby amended by adding the following underlined words:

8.0 - GENERAL DEVELOPMENT STANDARDS

8.1.5 Off-Street Parking General Requirements

- A. No parking is required for non-residential uses; however, if parking is provided it must meet all Code requirements.

AB. Location of Parking Spaces

1. All parking spaces required to serve buildings or uses erected or established after the effective date of this development code shall be located on the same zoning lot as the building or use served, except that parking spaces to serve business, commercial, industrial, and office buildings or uses may be located within 300 feet of such use if said spaces are located in a commercial or industrial district.
2. Buildings or uses existing on the effective date of this development code that are subsequently altered or enlarged so as to require the provision of parking spaces under this section, may be served by parking facilities located on land other than the zoning lot on which the building or use served is located, provided such facilities are within 300 feet of such use. Owners of property, nonconforming as to parking, who elect to provide parking and become conforming may locate such parking on land other than the zoning lot on which the building or use is located, as allowed in this section.
3. Off-street parking spaces, open to the sky, may be located in any yard except the required front yard or corner side yard. Enclosed buildings and carports containing off-street parking shall be subject to applicable yard requirements.

BC. Control of Parking Facilities

1. In cases where parking facilities are permitted on land other than the zoning lot on which the building or use served is located, such facilities shall be in the same possession as the zoning lot occupied by the building or use to which the parking facilities are accessory.
2. Private possession may be either by deed or long-term lease, the term of such lease to be approved by the Zoning Administrator; and such deed or lease shall be filed with the Zoning Administrator. The deed or lease shall require such owner or their heirs or assigns to maintain the required number of parking facilities for the duration of the use served or the deed or lease, whichever ends first.

CD. Size of Parking Stalls

1. Except for parallel parking spaces, each required off-street parking space shall be at least 8½ feet in width and at least 18½ feet in length, exclusive of access drives or aisles, ramps, columns, or office work areas.
2. Such space shall have a vertical clearance of at least seven feet, and shall be measured at right angles to the axis of the vehicle.
3. For parallel parking, the length of the parking space shall be 22 feet.

DE. Handicapped Accessible Parking

1. Any required parking area shall provide parking spaces designated and located to adequately accommodate the disabled, and these shall be clearly marked as such.
2. Markings shall include yellow striping on the pavement designated as the accessible parking space and shall provide a clearly posted sign as provided by Section 11-301 of the Illinois Vehicle Code. Signage shall clearly announce the fine for illegal parking in the accessible space as \$350.00.
3. Handicapped accessible parking spaces shall be designated nearest the accessible entrance (exit) to the facility. For the first 25 (or less) parking stalls required on a site, one shall be a handicapped accessible space. When more than 25 stalls are required, handicapped accessible parking shall be provided at the rates indicated in the 8.1.6. Such schedule of handicapped accessible parking rates shall be applicable to all districts.
4. Each stall shall be 16 feet in width, including either an eight-foot or five-foot diagonally striped access aisle, by 18½ feet in length. The access aisle can be located on either side of the vehicle portion of the accessible space. Any adjacent accessible parking space shall not share a common access aisle and no ramp shall be located within an access aisle. The aisle shall be kept free from any and all obstructions at all time. This shall include a prohibition against parking in the access aisle.

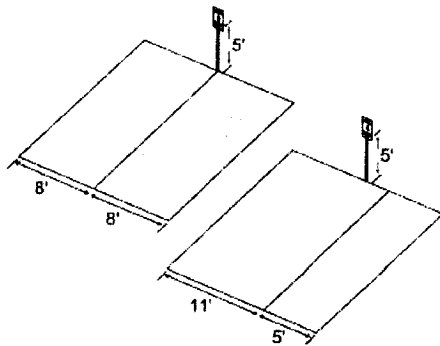

Above: Illustration of two examples of legal accessible parking spaces.

5. Slopes related to accessible parking spaces and access aisles shall not exceed a 1:50 ratio (two percent) in any direction. Exceptions may be granted for unusual terrain conditions. The Zoning Administrator shall have sole discretion to determine the existence of such unusual terrain conditions.
6. Ramps shall be constructed of slip-resistant material with hazardous warning texture and any adjacent sidewalk shall provide a width of unobstructed sidewalk space of at least 36 inches, including any ramp encroachment. The designation of handicapped accessible parking stalls shall constitute consent by the property owner to the enforcement of the restriction of such spaces to disabled motorists by the City.

EF. Access/Driveways

All off-street parking facilities shall be designed with appropriate means of vehicular access to a street or alley in a manner which will least interfere with traffic movement. All vehicular access/driveways shall be hard surfaced pursuant to paragraph G H.3 below. In any event, all driveways shall conform to all applicable driveway requirements adopted by the City.

1. The following driveway width regulations shall apply to all residential properties:
 - a. **Driveway width when located in the required yard for front, rear, or corner side yard.**
 A driveway leading to a garage shall not exceed fifteen (15) feet for a single stall garage; twenty (20) feet for a double stall garage; or thirty-four (34) feet for a triple stall garage. However, a driveway leading to a garage may include an extension, which leads to a legal parking space(s), provided the extension is designed with the least amount of hard-surfaced material as determined by the Zoning Administrator. In the absence of a garage, the driveway width serving any legal parking shall not exceed twenty (20) feet in width. Any garage larger than three (3) stalls must have the driveway width approved by the City traffic engineer.
 - b. **Driveway width when not located within the required yard for front, rear, or corner side yard.**
 A driveway leading to a garage shall not exceed the width of the garage. However, a driveway leading to a garage may include an extension, which leads to a legal parking space(s), provided the extension is designed with the least amount of hard-surfaced material as determined by the Zoning Administrator. In the absence of a garage, the driveway width serving any legal parking shall not exceed fifteen (15) feet for a single parking space; twenty (20) feet for a double parking space; or thirty-four (34) feet for a triple parking space.
 - c. The size of a driveway and any extension cannot conflict with the allowable number and location of parking spaces per 8.1.7D of this code.

FG. Use of Required Parking Spaces

Except as may otherwise be provided in the granting of a special use, required off-street parking facilities provided for uses listed in 8.1.6 below are solely for the parking of passenger automobiles of patrons, occupants, or employees of such uses.

GH. Design and Maintenance

1. **Plan**
 The design of parking lots or areas shall be subject to the approval of the Site Plan Review Board, in accordance with standards developed by the City Engineer.
2. **Character**
 Accessory parking spaces may be open to the sky, or enclosed in a building.
3. **Surfacing**
 All off-street parking facilities, including access, shall be surfaced with asphalt, Portland cement, interlocking concrete paver or brick, or bituminous cement binder pavement, and treated in such a manner as to provide a durable and dustless surface, and shall be graded and drained to dispose of all surface water and to provide effective drainage without allowing the water to cross the sidewalk or driveway. Parking area and access shall be constructed and maintained in a manner to provide an evenly paved surface, free from potholes, ruts, channels, growth of weeds, and other similar obstructions.
4. **Landscaping and Screening**

Landscaping and screening shall be provided in accordance with the requirements of 8.2.

5. Lighting

Any lighting used to illuminate off-street parking and loading areas shall be in accordance with 8.5.

6. Cleaning and Maintenance

Except in the industrial districts, no cleaning or maintenance of parking lots utilizing motorized equipment may be performed between 10:00 p.m. and 7:00 a.m. each day, except for the removal of snow. Parking areas in all districts, including access, shall be maintained in a manner to provide an evenly paved surface, free from potholes, ruts, channels, growth of weeds, and other similar obstructions.

7. Signage

Signage shall be permitted on parking areas in accordance with the provisions specified in 8.3.

8. Access

Each required off-street parking space must be independently maneuverable so that no vehicle shall be stored or parked so as to reduce the availability of any other off-street parking spaces below the minimum number of spaces required in 8.1.6.

8.1.6 Parking Schedule

- A. All off-street parking spaces ~~provided required by this development code~~, except those required for one- and two-family dwellings, shall be designed in accordance with one of the formulae set forth in the Off-Street Parking Schedule below. Off-street parking spaces shall be provided in accordance with the Off-Street Parking Schedule. In addition to the requirements of the Parking Schedule, a business must also provide one space for each business vehicle parked at the business. Parking spaces for accessory uses not specifically enumerated within a parking class shall be assumed to be included in the principal (permitted or special) use requirement. If, for any reason the classification of any use, for the purpose of determining the amount of off-street parking or the number of spaces to be provided by such use is not readily determinable, the parking class of such use shall be established by the Zoning Administrator.
- B. In computing required parking spaces, the total number of required spaces shall be based upon use(s) of the zoning lot or portion thereof. Therefore, one principal use may actually contain two or more parking class uses (e.g., retail sales and warehousing).
- C. In the event this ordinance does not specify the number of parking spaces for a specific use, the Zoning Administrator shall determine the number of spaces required. In making this determination of the number of spaces required for a proposed use, the Zoning Administrator shall consider the number of parking spaces required for the listed use most similar to the proposed use in terms of parked vehicles which are expected to be generated. In determining the number of parked vehicles likely to be generated by a use, the Administrator shall consider the square footage occupied by the use where appropriate. In the alternative, the Zoning Administrator may consider the number of employees and patrons which are anticipated for the proposed use.
- D. No required parking spaces are required in the B1 District. However, if parking is provided, other than the number of spaces, all other requirements as set forth in 8.1.5G above apply as though the spaces were required, with the exception of landscaping requirements.
- E. When determination of the number of off-street parking spaces required below results in a requirement of a fractional space, any fraction of less than one-half may be disregarded,

while a fraction of one-half or more, shall be counted as one parking space. Parking spaces required on an employee basis shall be based on the maximum number of employees on duty or residing or both, on the premises at any one time.

Off-Street Parking Schedule Minimum Parking Requirements: All Zoning Districts (Except B1 and all Form Districts)

Use	Number of required parking spaces
RESIDENTIAL	
Apartment Hotel	1 per unit
Bed and Breakfast	2 for the operator and 1 per guest room
Boarding House Dormitory Fraternity, Lodging House, Rooming House	1 per sleeping acc.
Convalescent Home, Nursing Home, Elderly Housing	1 per 3 residents + 1 per employee
Hotel/Motel	1.25 per guest room + 12 per 1,000 SF for convention facilities
Mobile Home Park	1.25 per unit
Multi-Family	2 per unit
Single and Two Family	2 per unit for units constructed after June 4, 1991 per unit + 1 for each permitted gratuitous guest for units constructed prior to June 4, 1991
Family Care Facility and Group Care Facility	1 per employee + 1 per resident (the resident parking requirement may be waived by the Zoning Administrator for those facilities that prohibit ownership or operation of motor vehicles by residents of the facility)

Off-Street Parking Schedule Maximum Parking Allowed—All Zoning Districts Except B1

The following table outlines the maximum parking number allowed by right; however, the maximum number may be exceeded if a fee is paid for over parking. The fee for over parking is \$250 per space up to 20% of the maximum allowed. A fee of \$500 per space is required for parking which exceeds 20% of the maximum allowed. This is applicable for all parking added after the effective date of this ordinance.

COMMERCIAL	
ATM	6 stacking spaces for 1 ATM on a site and 8 stacking spaces for 2 ATMs on a site
Auto Service	3 per service bay
Car Wash	4 stacking spaces per bay or stall, 15 stacking spaces per automated bay or stall plus 1 parking space per employee.
Drive Through Facility, non-ATM	8 stacking spaces for the first window, plus 2 stacking spaces for each additional window in addition to the parking required for that specific land use
Durable Goods, Furniture,	2 per 1,000 SF of GFA

Appliances, etc.	
Eating/Drinking	12 per 1,000 SF of GFA
Retail, freestanding	4 per 1,000 SF of GFA
Shopping Center	4 per 1,000 SF of GLA - 25,000 to 400,000 SF 4.5 to 5 in linear progression per 1,000 of GLA - 400,000 to 600,000 SF 5 per 1,000 SF of GLA - 600,000 + SF (adjustments to these requirements can be considered on a case by case basis pursuant to the Special Use process).
Wholesale	2 per 1,000 SF of GFA up to 10,000 SF + 0.5 per 1,000 SF remaining Office area parking requirements shall be calculated separately based on office parking rates.
SERVICE	
Beauty/Barbershop	3 per chair
Funeral Services	1 per 50 SF public access rooms + 1 per vehicle used in connection with the enterprise
Financial	4 per 1,000 SF of GFA
Gym/Health Club	5 per 1,000 SF of GFA + additional for outdoor accessory uses based on their requirements
Hospital	2 per bed + outpatient areas calculated at medical/dental rate
Medical/Dental	6 per 1,000 SF of GFA
Business and Professional Office	4 per 1,000 SF of GFA
Personal Services	3 per 1,000 SF of GFA
Religious Institution	1 per 4 seats
SCHOOLS AND LIBRARIES	
Dance/Music/Vocational/Trade	1 per employee + 2 per 3 students based on the maximum number of students attending classes on the premises at any one time
Day Care/Nursery	4 per 1,000 SF GFA
K—9th Grades	1 per employee + 4 for visitors
Library	3 per 1,000 SF GFA
Senior High School	1 per employee + 1 per 8 students
CULTURE/ENTERTAINMENT	
Amusement Establishment	1 per 3 persons capacity + 1 per employee
Arena/Stadium	1 per 4 seats
Bowling Alley	5 per lane
Club/Lodge	7 per 1,000 SF of GFA
Cultural Institution	1 per 400 SF of GFA
Golf Course	60 per 9 holes
Swimming Pool	1 per 15 SF of shallow water (5 feet or less) or wading area per

	bather; and 25 SF of deep water (deeper than 5 feet) per bather; and for every 50 SF of deck, 1 bather may be added to overall capacity.
Tennis Court	4 per court
Theater	1 per 4 seats
Manufacturing/Utility	1 per 2 employees + 1 per company vehicle
Research and Development	4 per 1,000 SF of GFA
Warehouse	2 per 1,000 SF of GFA up to 10,000 SF + 0.5 per 1,000 SF remaining Office area parking requirements shall be calculated separately based on office parking rates.
Airport	0.75 per airplane tie-down + 1 per 3 passengers whose departure originates from the facility
Bus Facility	1 per 2 employees + 1 per bus
Commuter Train/Bus Station	2 per 3 passengers whose departure originates from facility
Radio/TV Studio	4 per 1,000 SF of GFA

Handicapped Accessible Parking Requirements

Off-Street Parking Spaces Provided	Number of required parking spaces*
1 to 25	1
26 to 50	2
51 to 75	3
76 to 100	4
101 to 150	5
151 to 200	6
201 to 300	7
301 to 400	8
401 to 500	9
501 to 1000	2% of total number
Over 1000	20 plus 1 for each 100 spaces over 1000 spaces

* Medical Facilities that care for or treat patients with mobility impairments must designate 10% of the required parking spaces as handicapped for an outpatient facility or 20% for a facility that specializes in treatment or services for persons with mobility issues. Please reference the Illinois Accessibility Code for more information. Any regulations required by the Illinois Accessibility Code that are above and beyond this ordinance's scope will apply.

Bike Parking Requirements

<u>Off-Street Parking Spaces Provided</u>	<u>Number of bike parking spaces required</u>
<u>1 to 25</u>	<u>1</u>
<u>26 to 50</u>	<u>2</u>
<u>51 to 75</u>	<u>3</u>
<u>76 to 100</u>	<u>4</u>
<u>101 to 150</u>	<u>5</u>
<u>151 to 200</u>	<u>6</u>
<u>201 to 300</u>	<u>7</u>
<u>301 to 400</u>	<u>8</u>
<u>401 to 500</u>	<u>9</u>
<u>501 to 1000</u>	<u>2% of total number</u>
<u>Over 1000</u>	<u>20 plus 1 for each 100 spaces over 1000 spaces</u>

8.1.8 Off-Street Loading

A. Loading Facilities Required

No loading facilities shall be required for any use; however, where loading facilities are established, they shall meet all standards of this section.

B. Location

1. All loading berths shall be located on the same zoning lot as the use served. All motor vehicle loading berths which abut a residential district or an intervening alley separating a residential district from a commercial, industrial, or form district shall be fully screened from view, subject to approval by the Site Plan Review Board.
2. No loading berth shall be located within 30 feet of the nearest point of intersection of any two streets. No loading berth shall be located in a required front yard or corner side yard. Any loading berths located in a required rear yard may be open to the sky, provided they are not within 50 feet of the property line of any residential district. Loading berths or associated maneuvering areas shall not be located in any required transitional buffer yard.

C. Size

~~Unless otherwise specified, an off-street loading berth shall be at least 12 feet in width by at least 35 feet in length for short berths, and 12 feet in width by at least 50 feet in length for long berths exclusive of aisle and maneuvering space, and shall have a vertical clearance of at least 15 feet. Maneuvering aprons for short berths shall be at least 60 feet. Access lanes for short berths shall be 12 feet in width for one-way lanes and 22 feet in width for two-way lanes. For long berths, access lanes shall be 14 feet in width for one-way lanes and 24 feet in width for two-way lanes. Maneuvering aprons for long berths shall be at least 90 feet. Space dedicated for access lanes may also be considered as space for the maneuvering apron. There is no minimum of maximum size of loading berth; however, loading berths are subject to review and approval by the Site Plan Review Board.~~

D. Access

Each required off-street loading berth shall be designed with appropriate means of vehicular access to a street or alley in a manner which will least interfere with traffic movement, and shall be subject to approval by the Site Plan Review Board.

E. Surfacing

All open off-street loading berths shall be surfaced pursuant to 8.1.5G.H.3 above.

F. Utilization

Space allocated to any off-street loading use shall not, while so allocated, be used to satisfy the space requirements for any off-street parking facilities or portions thereof.

G. Central Loading

Central loading facilities may be substituted for loading berths on individual zoning lots, provided the following conditions are fulfilled:

1. Each zoning lot served shall have direct access to the central loading area without crossing streets or alleys at grade.
2. Total off-street loading berths provided shall meet the minimum requirements herein specified, based on the use of the several types of uses served (area of types of uses may be totaled before computing number of loading berths).
3. No zoning lot served shall be more than 500 feet away from the central loading area.
4. The tunnel or ramp connecting the central loading area with the zoning lot served shall be not less than seven feet in width and have a clearance of not less than seven feet.

Section 2. This Ordinance shall be in full force and effect from and after its passage and approval according to law.

PASSED BY THE CITY COUNCIL OF THE CITY OF PEORIA, ILLINOIS, THIS
28th DAY OF July, 2015.

APPROVED:



Mayor

ATTEST:

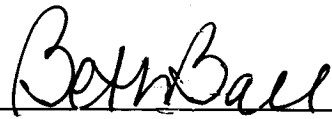

City Clerk

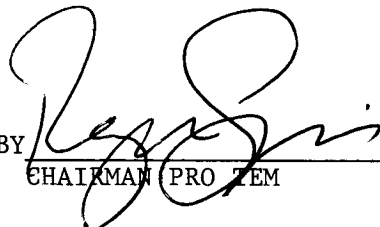

CHAIRMAN PRO TEM

EXAMINED AND APPROVED:



Corporation Counsel