

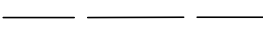

LEGEND

-  BOUNDARY OF VACATION
-  EXISTING PROPERTY LINE
-  NOT TO SCALE IRON
-  MONUMENT FOUND
-  3/4" IRON PIPE SET
- P.O.C.** POINT OF COMMENCEMENT
- P.O.B.** POINT OF BEGINNING

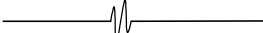

GENERAL NOTES:

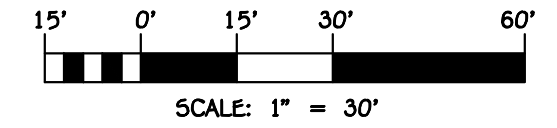
TOTAL AREA OF RIGHT-OF-WAY TO BE VACATED = 1367.7 SQ. FT.*
 BEARINGS BASED ON THE ILLINOIS STATE PLANE COORDINATE SYSTEM, WEST ZONE 1202.
 THE FINAL PLAT OF WOODROW WILSON SUBDIVISION IS RECORDED IN PLAT BOOK "U", PAGE 33 AT THE PEORIA COUNTY RECORDER'S OFFICE.
 RIGHT-OF-WAY BEING VACATED SHALL BE COMBINED WITH PIN 14-31-227-001.
 EXISTING RIGHT-OF-WAY LINES SHOWN WERE DEDICATED BY DOCUMENT NUMBER 60-2511 IN BOOK 1173 PAGE 761 AND DOCUMENT NUMBER 60-2510 IN BOOK 1173 PAGE 758 IN PEORIA COUNTY RECORDER'S OFFICE.

LEGAL DESCRIPTION OF A PART OF GALE AVENUE TO BE VACATED (603.3 SQ. FT. TRACT)

A PART OF LOT 4 IN WOODROW WILSON SUBDIVISION, A SUBDIVISION OF PART OF THE NORTHEAST QUARTER OF SECTION THIRTY-ONE (31), TOWNSHIP NINE (9) NORTH, RANGE EIGHT (8) EAST OF THE FOURTH PRINCIPAL MERIDIAN, PEORIA COUNTY, ILLINOIS BEING MORE PARTICULARLY DESCRIBED AS FOLLOWS:
 COMMENCING AT THE SOUTHEAST CORNER OF LOT 5 IN SAID WOODROW WILSON SUBDIVISION, THENCE NORTH 08°-24'-48" WEST, (BEARINGS BASED ON THE ILLINOIS STATE PLANE COORDINATE SYSTEM, WEST ZONE 1202), ALONG THE SOUTH LINE OF SAID LOT 5 AND THE SOUTH LINE OF SAID LOT 4, 102.04 FEET TO THE POINT OF BEGINNING OF THE TRACT TO BE DESCRIBED: FROM THE POINT OF BEGINNING, THENCE CONTINUING NORTH 08°-24'-48" WEST, ALONG SAID SOUTH LINE OF LOT 4, 9.54 FEET; THENCE NORTH 30°-39'-02" WEST, 67.95 FEET; THENCE NORTH 00°-00'-00" WEST, 14.90 FEET TO THE EXISTING NORTHEASTERLY RIGHT-OF-WAY LINE OF GALE AVENUE; THENCE SOUTH 30°-57'-50" EAST, ALONG SAID EXISTING NORTHEASTERLY RIGHT-OF-WAY LINE, 85.86 FEET TO THE POINT OF BEGINNING, SAID TRACT CONTAINING 603.3 SQ. FT., MORE OR LESS.

LEGAL DESCRIPTION OF A PART OF FORREST HILL AVENUE TO BE VACATED (764.4 SQ. FT. TRACT)

A PART OF LOT 4 AND A PART OF LOT 5 IN WOODROW WILSON SUBDIVISION, A SUBDIVISION OF PART OF THE NORTHEAST QUARTER OF SECTION THIRTY-ONE (31), TOWNSHIP NINE (9) NORTH, RANGE EIGHT (8) EAST OF THE FOURTH PRINCIPAL MERIDIAN, PEORIA COUNTY, ILLINOIS BEING MORE PARTICULARLY DESCRIBED AS FOLLOWS:
 COMMENCING AT THE SOUTHEAST CORNER OF LOT 5 IN SAID WOODROW WILSON SUBDIVISION, THENCE NORTH 01°-35'-40" EAST, (BEARINGS BASED ON THE ILLINOIS STATE PLANE COORDINATE SYSTEM, WEST ZONE 1202), ALONG THE EAST LINE OF SAID LOT 5, 98.50 FEET TO THE EXISTING SOUTH RIGHT-OF-WAY LINE OF FORREST HILL AVENUE AND THE POINT OF BEGINNING OF THE TRACT TO BE DESCRIBED: FROM THE POINT OF BEGINNING, THENCE NORTH 89°-42'-56" WEST, ALONG SAID EXISTING SOUTH RIGHT-OF-WAY LINE, 133.49 FEET; THENCE NORTH 75°-32'-18" EAST, 20.12 FEET; THENCE NORTH 05°-35'-25" EAST, 14.93 FEET; THENCE SOUTH 89°-42'-56" EAST, 99.30 FEET TO THE EAST LINE OF SAID LOT 5; THENCE SOUTH 01°-35'-40" WEST, ALONG SAID EAST LINE OF LOT 5, 6.34 FEET TO THE POINT OF BEGINNING, SAID TRACT CONTAINING 764.4 SQ. FT., MORE OR LESS.

RIGHT OF WAY VACATION PLAT

A PART OF LOT 4 AND LOT 5 OF WOODROW WILSON SUBDIVISION BEING A PART OF THE NE 1/4 OF SEC. 31, T9N, R8E, 4TH P.M., PEORIA COUNTY, ILLINOIS.

FOR: **GLOBAL ONE PROPERTIES** DATE: 5/25/17

AE AUSTIN ENGINEERING, CO., INC.
 Consulting Engineers / Surveyors
 311 SW Water St., Suite 215
 Peoria, Illinois 61602
 License No. 184-001143



SURVEYED	JAG/WLC	DRAWN	MPC/SLB	APPROVED	MPC
SCALE	1" = 30'	PROJECT NUMBER	76-17-014	BOOK	PAGE

BY: _____
 MICHAEL P. COCHRAN
 ILLINOIS PROFESSIONAL LAND SURVEYOR No. 3879
 AUSTIN ENGINEERING COMPANY, INC. (309)691-0224
 311 SW WATER ST., SUITE 215, PEORIA, IL 61602
 mcochrán@austinengineeringcompany.com

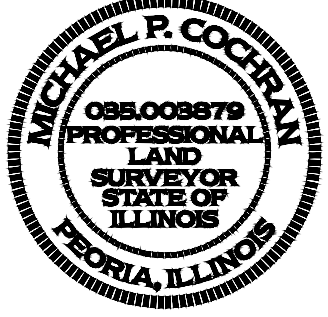

LICENSE EXPIRES NOVEMBER 30, 2018