



Proposal
For
The City of Peoria, Illinois



2014-2015 Process Improvement Program

Submitted by / Reply to:

David Krings
Director, Non-Profit & Local Government Solutions
513-200-4222
krings@techsolve.org

October 13, 2014

Mr. Patrick Urich
City Manager
Peoria, Illinois
419 Fulton, Suite 207
Peoria, Illinois 61602

RE: 2014-2015 City of Peoria Process Improvement Program

Dear Patrick:

Thank you for the opportunity to provide Process Improvement Training for your department heads and to facilitate the hiring and onboarding process improvement event. I very much enjoyed working with you and your staff.

I also very much appreciate your request that I prepare a proposal for four more engagements. I also well understand your request for a discount from our normal rates for contracting for multiple events.

I propose that we maintain the pricing originally propose in 2013 for one day of training and a single three day event and now contract for four such engagements at that rate and then conduct a fifth event at a 50% discount.

I believe that such a series of process improvement event will result in the City having a core group of internal event facilitators who will assist you on a daily basis in the growth of your continuous improvement culture.

If you have any questions regarding the content of this response, or need more information, please contact me at your convenience.

Sincerely,



David Krings
Director, Non-Profit & Local Government Solutions

PROPOSED SERVICES – PROCESS IMPROVEMENT TRAINING

TechSolve will present a series of one-day courses to senior managers and others of your choosing. This training course is a high-level, intensive look at the principles and philosophy of successful continuous improvement efforts within organizations of all types.

TechSolve will discuss what it takes to successfully implement these tools and sustain gains. It will also cover the importance of value stream management, correct performance measurements, and creating a continuous improvement culture within the organization. The training will be a very hands-on event with thorough discussion on its application to the City.

DELIVERABLES

1. Employees trained on Lean Methodologies and continuous improvement.
2. Opportunities to incorporate best practices and Lean Concepts into the organization.
3. Electronic copy of the PowerPoint presentation.

TRAIN THE TRAINER – PROCESS IMPROVEMENT EVENTS

The following process improvement approach will be used for each event the City chooses to conduct.

During the first event, the emphasis will be on improving the processes as well as training selected staff to conduct process improvement events without external help. TechSolve will conduct and lead the first event. A combination of TechSolve and City staff, with TechSolve coaching, will lead the subsequent events according to a mutually agreed to schedule of improvement events. TechSolve staff will also be available, without additional charge, by phone as the City facilitators get their sea legs.

Each event will help build a culture of continuous process improvement.

PROCESS IMPROVEMENT APPROACH

As a result of performing similar engagements across the country, TechSolve has found that the amount of involvement the staff has in the process improvements (and all associated tasks) directly corresponds to the success of the proposed implementation plan. Therefore, TechSolve recommends that a cross-functional group be involved throughout the event(s). This enables the project team to take ownership in the process, provide first-hand knowledge of the process nuances, and facilitate grassroots communication to their respective department staff.

The following is TechSolve's proposed approach broken down into tasks.

PRE-EVENT ACTIVITIES

Stakeholder Group Identification

An initial conference call will be conducted with the project sponsor to identify the members of the core implementation team / stakeholder group. The team selection will be facilitated to assemble an effective inter-departmental team that is effective in identifying opportunities for

improvement and empowered to implement the recommendations. The team could also include representatives from staff departments such as the IT and Legal Departments.

Data Gathering & Analysis

Data collection is very important in any improvement event. Data will include any performance measures currently tracked, workflows of the department, and the process. The data that will be gathered will be determined in a chartering meeting.

ON-SITE EVENT

On-site participants will address all phases of the process chosen for examination. Processes will be examined for improvements in efficiency, effectiveness, and policy.

Process Mapping / Value Stream Mapping

Three days will be spent performing each on-site event. The event can be broken down into the following sub-tasks:

1. Understand the “Current State” of the process
2. Create a visual map of the process
3. Identify non-value-added activities and improvement opportunities
4. Document a visual map of the new and improved process (Future State)
5. Prioritize improvements and develop improvement plan
6. Create a value stream tracking center
7. Implement improvements (including “Just-Do-Its”)

Identifying New Performance Metrics and Targets

Based on the Current/Future State Maps, TechSolve and the City will identify the metrics that will help to achieve, sustain, and continuously improve the Future State. The team will also calculate the baseline measures from the data collected during the Current State mapping process, develop consensus and commitment to the metrics, and determine exactly how the metric will be calculated.

DELIVERABLES

TechSolve will provide one electronic copy of the final presentation, which may be emailed as an attachment or provided on a compact disc. It will include the following deliverables.

Current State Map

This is a detailed documentation of each step in the process. It will be in the “swim lane” format, which places emphasis on concurrent steps and multiple handoffs. Each step will be accompanied by key process metrics (such as cycle time and error percentage). This Map will also capture “wastes” and opportunities for improvement.

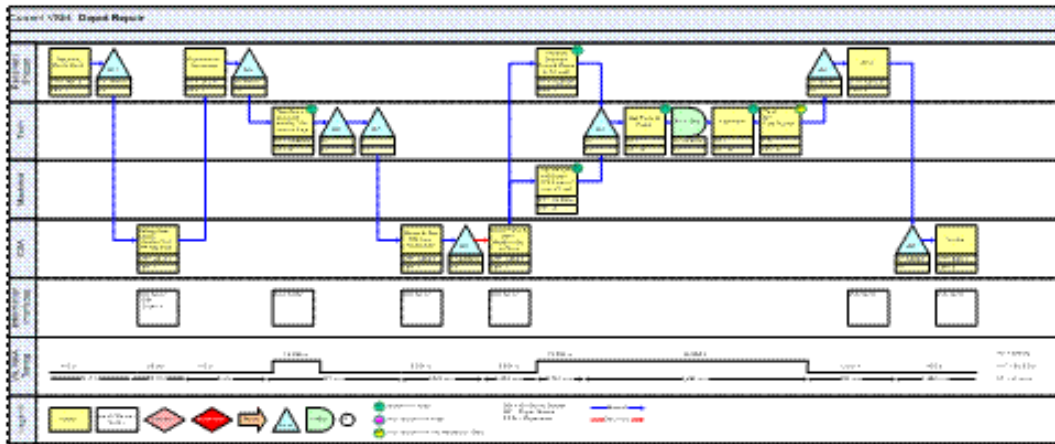

Example of Current State Map

Future State Map

Similar to the Current State Map, a Future State Map is a detailed documentation of each step in the improved future process. The steps are accompanied by key process metrics and improvement projects (which are required to achieve the Future State).

The Future State will address all areas of concern identified in the development of the initial process map. It is anticipated that the City will be able to use the data developed in the future process design to place the time taken for the various steps in a context for management purposes.

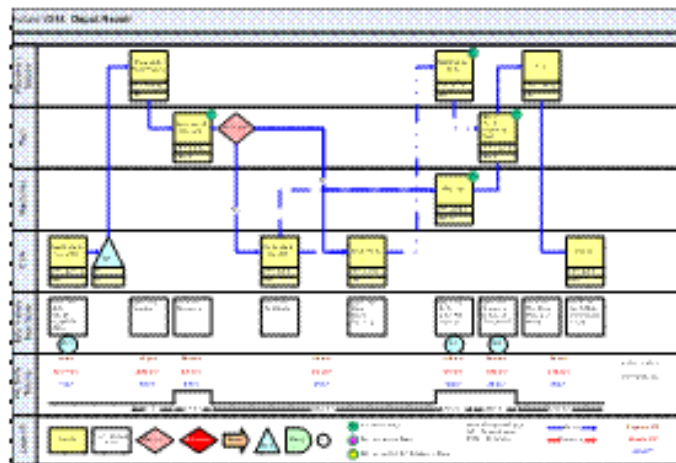

Example of Improved, Future State Map

Roadmap for Implementation

The roadmap is what bridges the current and future states of the process. It documents all changes that need to be made and categorizes them as “Just-Do-Its” or “projects”. It also contains responsibilities and a timeline.

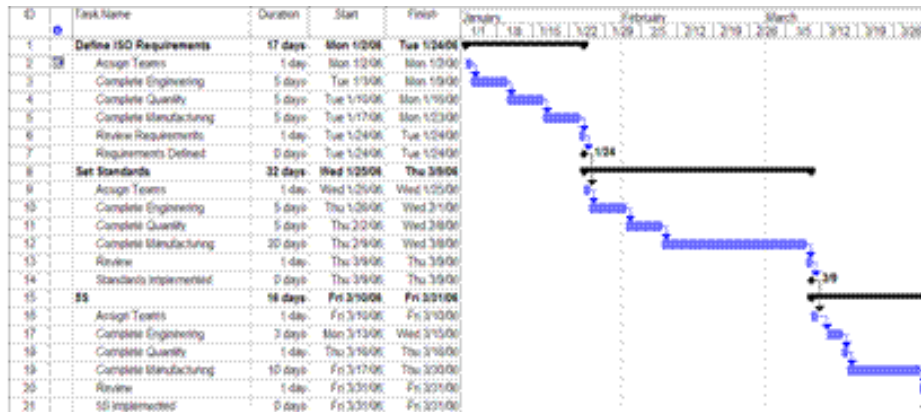

Example of Implementation Roadmap

Performance Metrics and Tracking Center

The tracking center is important in ensuring accountability. It will be comprised of the three previous components and space for ongoing metrics. The Tracking Center is to be prepared by City staff with TechSolve assistance as needed and will be displayed in a high-traffic area for everyone to view.

After-Project Consultation

TechSolve will be available for phone consultations with City staff as each project is completed to assist in process improvement efforts.

TIMING

TechSolve's Director of Non-Profit and Local Government Solutions, David Krings, and other TechSolve personnel (as necessary) will be available at any point during the engagement for public or private presentations to the City managerial and/or policy leaders. Mr. Krings has over 40 years of experience at top levels of municipal, county, and state government and is quite comfortable in that environment.

Scheduling for the project will be developed to meet the City staff schedules.

INVESTMENT

For each of four training and improvement events:	\$12,500
For a fifth training and improvement event:	\$ 6,250

*Plus all travel and other out-of-pocket expenses, including administrative processing charges.

TERMS AND CONDITIONS

1. **Terms and Conditions Applicable.** The Terms and conditions set forth herein shall apply to any and all orders made by the Purchaser for any or all of the products and/or services described in the Proposal. These terms and conditions comprise all of the terms and conditions of TECHSOLVE and the Purchaser respecting the subject matter of the Proposal, except to the extent that any terms or conditions shall have been changed or modified in the Proposal. Any other changes or modifications in the terms and conditions contained herein must be specifically agreed to in writing by TECHSOLVE. All representations, promises, warranties or statements by any agent or employee of TECHSOLVE that differ in any way from the terms and conditions hereof shall have no

effect. Any additional contradictory or different terms contained in any initial or subsequent order or communication from Purchaser pertaining to the goods are hereby objected to and shall be of no effect. No course of prior dealings between the parties and no usage of the trade shall be relevant to supplement or explain any terms used in this Agreement. Acceptance or acquiescence in a course of performance rendered under this Agreement shall not be relevant to determine the meaning of this Agreement even though the accepting or acquiescing party has knowledge of the nature of the performance and the opportunity for objection. All orders are subject to the approval by TECHSOLVE. No waiver or alteration of terms herein shall be binding unless in writing and signed by an executive officer of TECHSOLVE.

2. **Price in Proposal.** The price or prices quoted in the Proposal are firm for the number of days set forth in the Proposal, except that such price or prices may be adjusted upward or downward without notice in the event of: (i) alterations in specifications, quantities, designs or delivery schedules; (ii) increases in the cost of fuel, power, material, supplies, or labor; and/or (iii) foreign or domestic legislation enacted by any level of government, including tax legislation, which increases the cost of producing, warehousing, or selling the goods purchased hereunder.

3. **Acceptance of Proposal.** The use of a purchase order or other instrument to indicate acceptance shall be considered to be for the convenience of the Purchaser only and any terms and conditions set forth therein shall be of no force or affect whatsoever.

4. **Rescheduling.** Purchaser may cancel and reschedule a scheduled TECHSOLVE activity by providing TECHSOLVE with notice of its need to cancel and reschedule a minimum of seven business days prior to the date when the activity is scheduled to take place. Should Purchaser cancel an activity with less than seven business days prior notice, Purchaser agrees to pay TechSolve a "lost opportunity" fee equal to Two Thousand Five Hundred Dollars and No Cents (\$2,500.00).

5. **Cancellations.** Orders for less than all of the goods and/or services are not acceptable unless specifically provided in this Proposal or written consent is given by TECHSOLVE. Orders made pursuant to this Proposal may not be canceled for any reason without the written consent of TECHSOLVE. Cancellation or suspension of orders, if consented to by TECHSOLVE, will be upon terms that indemnify TECHSOLVE for liabilities and expenses incurred and for commitments made by TECHSOLVE and which provide for profit on work in process and for the contract value of goods completed and ready for shipment and a cancellation fee equal to ten percent (10%) of the Proposal price. This provision shall not preclude TECHSOLVE from recovering all damages and costs of whatever nature permitted under the Uniform Commercial Code.

6. **Delivery.** Any shipping dates or completion dates set forth in the Proposal or in an agreement that shall result from the Proposal are approximate and time shall not be considered of the essence. Failure to effect shipment or completion by such estimated delivery or completion date will not be considered sufficient cause of cancellation without prior agreement confirmed in writing by an authorized agent of TECHSOLVE.

7. **Risk of Loss.** Notwithstanding title to or ownership of products, risk of loss shall pass to the Purchaser as soon as the products are identified to any contract that shall have arisen from the Proposal.

8. **Non-solicitation.** During the course of the delivery of the services covered by this proposal and for a period of two years after the completion or termination of this work, Purchaser will not directly or indirectly solicit, employ or retain in any capacity, or directly or indirectly offer to employ or retain in any capacity, any personnel of TECHSOLVE who are working or have worked on the Purchasers' project(s).

9. **Taxes and Fees.** Any taxes or fees imposed by any federal, state, municipal or other governmental authority that may be applicable to the sale, use, delivery or transportation of the products or services that may be sold by reason of any contract arising out of this Proposal and any and all duties, tariffs, brokerage charges, shall be added to the price of the order and paid by the Purchaser, except where the Purchaser shall have provided a proper certification of exemption there from. The price for the products and/or services purchased is net of sales, use, excise or similar taxes, whether federal, state, or local. All orders are subject to an increase in price in the event any federal or state legislation, including tax legislation, comes into effect and increases the cost of production of any goods and/or services purchased. Such price increase shall not be greater than the increased cost of production.

10. **Method of Shipment.** Unless otherwise set forth in the Proposal, all shipments made pursuant to any contract arising out of this Proposal shall be made F.O.B. Cincinnati, Ohio or the nearest stocking point. In the event that Purchaser shall specify a method of shipment other than that specified in this Proposal, TECHSOLVE agrees to ship by that method provided that the price shall be adjusted to reflect any increase or decrease in the price to the extent that the cost of shipment is or will be included therein, and provided further that such shipment method shall not modify the risk of loss as specified in this Proposal.

11. **Terms of Payment.** Unless otherwise specified in this Proposal, any products and/or services ordered pursuant to this Proposal shall be paid upon receipt of invoice. Unless otherwise noted in the Proposal, all contracts involving an amount greater than \$10,000 will be invoiced monthly based upon the time devoted to the engagement in the prior month. If Purchaser defaults with respect to any payment described here and above, it shall pay TECHSOLVE for all costs and expenses, including legal expenses and attorney's fees, incurred by TECHSOLVE in exercising any of its rights or remedies. The unpaid balance after thirty (30) days shall be subject to a late charge of 1 ½% per month.

12. **Security Interest.** Until full payment of the purchase price for any products and/or services ordered pursuant to this Proposal, TECHSOLVE shall retain a security interest in such products and may, at its option and without further agreement or signature of the Purchaser, file evidence of such security interest pursuant to the Uniform Commercial Code.

13. **Warranties.** TECHSOLVE warrants that it will perform the services in a workmanlike manner. THIS WARRANTY IS GIVEN IN LIEU OF ANY OTHER REPRESENTATION OR WARRANTY, EXPRESS OR IMPLIED. SELLER MAKES NO OTHER WARRANTIES, EXPRESS OR IMPLIED, INCLUDING THE IMPLIED WARRANTIES OF MERCHANTABILITY AND FITNESS FOR A PARTICULAR PURPOSE WHICH ARE HEREBY DISCLAIMED AND EXCLUDED BY SELLER. TECHSOLVE SHALL NOT BE LIABLE TO BUYER FOR ANY LOSS, CLAIM, DEMAND, LIABILITY, COST, DAMAGE OR EXPENSE OF ANY KIND CAUSED OR ALLEGED TO BE CAUSED, DIRECTLY OR INDIRECTLY, BY THE GOODS OR SERVICES OR BY ANY INADEQUACIES THEREOF, INCLUDING, WITHOUT LIMITATION, ANY LOSS OF BUSINESS, PROFITS, CONSEQUENTIAL, INCIDENTAL,

SPECIAL OR OTHER DAMAGE OF ANY NATURE, WHETHER ARISING IN TORT, CONTRACT, WARRANTY OR STRICT LIABILITY.

14. Limitation on Warranty Liabilities. The sole and exclusive remedies of the Purchaser shall be, at the option of TECHSOLVE, the return of the products and repayment of the price or the repair and replacement of nonconforming products or services. TECHSOLVE will not accept the return of any goods without its prior written consent. In no event shall TECHSOLVE be responsible for incidental or consequential damages from any defect in the goods, the application or use of the goods to or with Purchaser's products or services or breach of warranty including, but not limited to, Purchaser's or any other person's loss of material or profits, increased expense of operation, downtime or reconstruction of work, or damages arising out of any products liability claim and, in no event shall TECHSOLVE'S liability (whether under the theories of breach of contract or warranty, negligence, or strict liability) exceed the contract price paid for the goods or services delivered by TECHSOLVE. These remedies are the exclusive and sole remedies for any breach of warranty. Purchaser shall give written notice to the TECHSOLVE of any claim for breach of warranty within thirty (30) days after receipt of the goods or completion of the services. Any remedy of the Purchaser against TECHSOLVE shall be barred unless notice is given in accordance with the foregoing provisions. All actions by the Purchaser for breach of warranty against the TECHSOLVE shall be brought within one year after the cause of action thereon accrues. TECHSOLVE shall be given a reasonable and prompt opportunity to investigate any goods or services concerning which a claim is made.

15. Product Liability Disclaimer. Purchaser acknowledges that TECHSOLVE has no control over, and is not responsible for, the manner in which the products will be used or otherwise dealt with by the Purchaser. TECHSOLVE disclaims any liability, whether under the theory of tort, contract, warranty or strict liability for any loss, damage or injury arising out of the handling or use by Purchaser, the party to whom the goods were shipped, the party to whom the goods were billed, or any other person using the goods sold hereunder, or any loss or damage to the underlying products of the Purchaser to which the goods sold hereunder relate. TECHSOLVE further disclaims any liability under the theory of tort, contract, warranty or strict liability for any foreseeable results arising out of such loss or damage to the underlying products of Purchaser to which the goods sold hereunder relate, whether such loss or damage may arise by processes used or actions taken by TECHSOLVE or otherwise. TECHSOLVE shall be indemnified by Purchaser for any losses, damages or injuries for which TECHSOLVE may be held liable, which are caused by TECHSOLVE'S products due to any improper application or use of TECHSOLVE'S goods by Purchaser.

16. Proprietary Rights. Any and all models, drawings, sketches, plans and other information supplied by one party to the other shall remain the property of the party who supplied such. The other party may not use any such material or information except with respect to the products and/or services dealt within this Proposal. Any product or service sold under an agreement resulting from this Proposal shall not constitute a license to use any of the proprietary rights of TECHSOLVE.

17. Applicable Law. The terms and conditions of any contract arising out of the Proposal shall be construed in accordance with the laws of the State of Ohio without reference to conflict of laws.

18. General Conditions.

- a. No agent, salesman or other party is authorized to bind TECHSOLVE by an agreement, warranty, statement, promise or understanding not herein expressed.
- b. Any suit, action or proceeding arising out of the sale hereof shall be instituted by either party in the courts of the State of Ohio, Hamilton County, or United States District Court for the Southern District of Ohio, Western Division and TECHSOLVE and Purchaser irrevocably and unconditionally submit and consent to the jurisdiction and venue of any such court for such purpose, and each waives any obligation it may have as to the venue of any dispute arising out of or in connection with this transaction.
- c. Any clerical errors are subject to correction.

19. Force Majeure. TECHSOLVE shall not be liable for any loss, damage, delay, changes in shipment, schedules or failure to deliver, whether arising in tort, contract or warranty, caused by accident, fires, strikes, riots, civil commotion, embargoes, failure of carriers, inability to obtain transportation facilities, foreign or local governmental requirements, acts of God, prior orders from customers or limitations on TECHSOLVE'S or its suppliers' production or any other causes of contingency beyond TECHSOLVE'S control. In such event, TECHSOLVE shall not be liable for any consequential, incidental or special damages to Purchaser. TECHSOLVE may, at its option and without liability, cancel all or any portion of this Agreement and/or extend any date upon which performance hereunder is due.

AUTHORIZATION

In accepting this proposal, please return a signed copy and your organization's Purchase Order to the address below:

TechSolve, Inc.
6705 Steger Drive
Cincinnati, Ohio 45237
Attn: John Garter
Fax: (513) 948-2109

TechSolve will begin work after receipt of your signed authorizations. This proposal is valid for 60 days.

ACCEPTED:

Patrick Urich
City Manager
City of Peoria
City Hall
419 Fulton Street
Peoria, Illinois 61602

By: _____

Date: _____

Title: _____

P.O. No. _____

Signature: _____

ACCEPTED: Gary Conley
President
TechSolve, Inc.
6705 Steger Drive
Cincinnati, OH 45237

Signature: _____

Date: _____
