

SUBMITTED BY:

HOROWITZ CONCRETE

CONTRACTOR'S NAME

128 LEGION LN.

CONTRACTOR'S ADDRESS

E. PEORIA IL 61611

CITY, STATE, ZIP

STATE OF ILLINOIS

CITY OF PEORIA

COUNTY OF PEORIA

SPECIFICATIONS, PLANS, MATERIAL
QUANTITIES AND CONTRACT PROPOSAL

FOR

SIDEWALK PARTICIPATION PROGRAM 2016

TO BE CONSTRUCTED UNDER THE PROVISIONS OF
THE CITY OF PEORIA

BID OPENING:

Thursday, April 28, 2016, 11:00 A.M.

BID AWARDED: MAY 10 2016 BY CITY COUNCIL ITEM #16-148

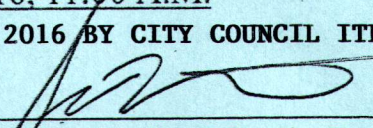

Scott Reise, P.E., City Engineer

**CITY OF PEORIA
CONTRACT**

This agreement, made and entered into this _____ day of _____, 2015, by and between the City of Peoria, an Illinois Municipal Corporation, Party of The First Part, and HOROWITZ CONCRETE, Party of The Second Part for the improvement known as the SIDEWALK PARTICIPATION PROGRAM - 2016;

WITNESSETH: That for and in consideration of the payments and agreements mentioned in the proposal hereto attached, to be made and performed by the Party of the First Part, and according to the terms expressed in the bond referring to these presents, the Party of The Second Part agrees with said Party of The First Part, at his/their own proper cost and expense to furnish and deliver all the work, materials and supplies in accordance with the specifications contained in said proposal, and in full compliance with all the terms of this agreement, for the amount of FOUR HUNDRED TWENTY FIVE THOUSAND AND NO/100 DOLLARS (\$425,000.00).

IT IS UNDERSTOOD AND AGREED that the instructions to bidders, proposal, bid, specifications, performance bond and maintenance bond are component parts of this contract and shall be deemed a part hereof. It is also understood and agreed that the contractor shall not assign, transfer, convey or otherwise dispose of this contract, or his right to execute it, or his right, title or interest in or to it or any part thereof, unless the previous written consent of the City Manager of the City of Peoria shall first be obtained thereto.

EMPLOYEE/EMPLOYMENT RESTRICTIONS – THE CONTRACTOR:

THE CONTRACTOR (hereinafter referred to as “SERVICE PROVIDER”) agrees, as a condition of accepting this contract with the City of Peoria, that, for a period of one (1) year following completion of this contract, it shall be prohibited from hiring, directly or indirectly, any City employee or official who was involved, directly or indirectly in: (1) the selection and/or recommendation to select the SERVICE PROVIDER for performance of this contract; (2) coordinating the efforts of the SERVICE PROVIDER in the consummation or completion of this contract; or (3) monitoring or determining the performance of the SERVICE PROVIDER. The SERVICE PROVIDER further acknowledges and agrees that, upon the City’s determination that a violation of this provision has occurred, the penalty imposed, at the sole discretion of the City, may include one or more of the following: (1) cancellation of any other contract(s) between the City of Peoria and the SERVICE PROVIDER; (2) disqualification of the SERVICE PROVIDER from bidding or being awarded future contracts with the City of Peoria for a period of two [2] years; and/or (3) payment of liquidated damages to the City of Peoria in the amount of TWENTY FIVE THOUSAND DOLLARS (\$25,000.00). This does not apply to any City Employee involved in the 2011-12 reduction in force; nor does it apply to parties taking the Early Retirement incentive offered by the City from November 1, 2011 through November 1, 2012.

IN WITNESS WHEREOF, the said parties have executed these presents on the date above mentioned.

THE CITY OF PEORIA

BY: *Pat Uhl*
City Manager

ATTEST: *Becky Ball*
City Clerk

EXAMINED AND APPROVED:
Donald B. Leist
Corporation Counsel

PARTY OF THE SECOND PART

HOROWITZ CONCRETE
(name of individual, firm or corporation)

BY: *DARIN HOROWITZ Dan Hagg*
(member of firm or officer of corporation)

(If a Co-Partnership)
_____(seal)
_____(seal)

Partners doing business under the firm name
of _____(seal)
(PARTY OF THE SECOND PART)

(If an Individual)
_____(seal)
(PARTY OF THE SECOND PART)

CITY OF PEORIA
PERFORMANCE BOND

BOND # RMI2163401

KNOW ALL MEN BY THESE PRESENTS, That I/we HOROWITZ CONCRETE, INC.,

an individual, of _____

a co-partnership, of _____

a corporation organized under the laws of the State of ILLINOIS

as Principal, and OLD REPUBLIC SURETY COMPANY

a corporation organized and existing under the laws of the State of WISCONSIN with authority to do business in the State of Illinois, as Surety, are held and firmly bound unto the City of

Peoria, Peoria County, State of Illinois, in the penal sum of _____

FOUR HUNDRED TWENTY FIVE THOUSAND AND NO/100 Dollars (\$425,000.00) lawful money of the United States, well and truly to be paid unto said City of Peoria for the payment of which we bind ourselves, our heirs, executors, administrators, successors, and assigns, jointly, severally, and firmly by these presents.

THE CONDITION OF THE FOREGOING OBLIGATIONS IS SUCH that whereas, the said Principal

has entered into a contract with the City of Peoria for SIDEWALK PARTICIPATION PROGRAM 2016

in accordance with the terms and conditions of said contract, which is hereby referred to and made a part hereof as if fully set forth herein;

NOW, THEREFOR, the condition of this obligation is such, that if the above bounden Principal shall well and truly keep, do and perform, each and every, all and singular, the matters and things in said contract set forth and specified to be by said Principal kept, done and performed, at the times and in the manner in said contract specified, or shall pay over, make good and reimburse the City of Peoria, all loss and damage which it may sustain by reason of the failure or default on the part of the Principal so to do, then this obligation shall be null and void; otherwise to remain in full force and effect.

IN WITNESS WHEREOF, we have duly executed the foregoing Obligation this 25TH day of MAY, 2016.

FOR THE CITY OF PEORIA

EXAMINED AND APPROVED:

Donald B. Leist

Corporation Counsel

Darin Horowitz
Principal
DARIN HOROWITZ / PRESIDENT
OLD REPUBLIC SURETY COMPANY

BY:

Jeffrey A. Petefish
Sureties
JEFFREY A. PETEFISH
ATTORNEY-IN-FACT

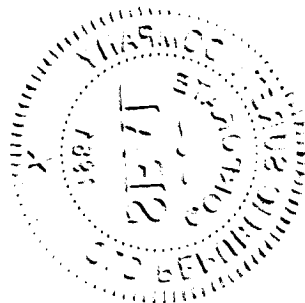

STATE OF ILLINOIS)
) SS
COUNTY OF PEORIA)

I, PHYLLIS D MALONEY, a Notary Public in and for said County, in the State aforesaid, do hereby certify that JEFFREY A PETEFISH, who is personally known to me to be the same person who signed the above foregoing instrument as the Attorney in Fact for OLD REPUBLIC SURETY COMPANY, appeared before me this day in person and acknowledged that he signed the name of JEFFREY A PETEFISH, thereto, as his Principal, and his own name as Attorney in Fact, as the free and voluntary act of his said Principal for the uses and purposes therein set forth, and that he executed the said instrument under authority given him by his said Principal.

Given under my hand and Notarial Seal, this 25TH day of MAY, 2016.

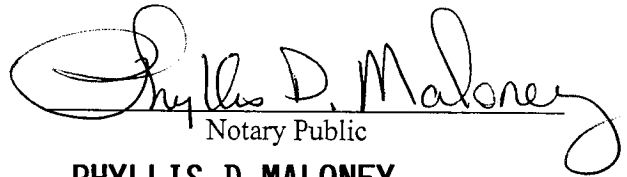
Notary Public
PHYLLIS D MALONEY

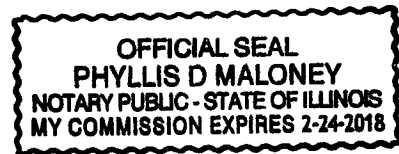

KNOW ALL MEN BY THESE PRESENTS: That OLD REPUBLIC SURETY COMPANY, a Wisconsin stock insurance corporation, does make, constitute and appoint:

ROBERT D. BIELENBERG, LARRY K. BIELEMA, JEFFREY A. PETEFISH, OF PEORIA, IL

its true and lawful Attorney(s)-in-Fact, with full power and authority, not exceeding \$20,000,000, for and on behalf of the company as surety, to execute and deliver and affix the seal of the company thereto (if a seal is required), bonds, undertakings, recognizances or other written obligations in the nature thereof, (other than bail bonds, bank depository bonds, mortgage deficiency bonds, mortgage guaranty bonds, guarantees of installment paper and note guaranty bonds, self-insurance workers compensation bonds guaranteeing payment of benefits, asbestos abatement contract bonds, waste management bonds, hazardous waste remediation bonds or black lung bonds), as follows:

ALL WRITTEN INSTRUMENTS IN AN AMOUNT NOT TO EXCEED AN AGGREGATE OF TWO MILLION DOLLARS(\$2,000,000)----- FOR ANY SINGLE OBLIGATION, REGARDLESS OF THE NUMBER OF INSTRUMENTS ISSUED FOR THE OBLIGATION.

and to bind OLD REPUBLIC SURETY COMPANY thereby, and all of the acts of said Attorneys-in-Fact, pursuant to these presents, are ratified and confirmed. This document is not valid unless printed on colored background and is multi-colored. This appointment is made under and by authority of the board of directors at a special meeting held on February 18, 1982. This Power of Attorney is signed and sealed by facsimile under and by the authority of the following resolutions adopted by the board of directors of the OLD REPUBLIC SURETY COMPANY on February 18, 1982.

RESOLVED that, the president, any vice-president, or assistant vice president, in conjunction with the secretary or any assistant secretary, may appoint attorneys-in-fact or agents with authority as defined or limited in the instrument evidencing the appointment in each case, for and on behalf of the company to execute and deliver and affix the seal of the company to bonds, undertakings, recognizances, and suretyship obligations of all kinds; and said officers may remove any such attorney-in-fact or agent and revoke any Power of Attorney previously granted to such person.

RESOLVED FURTHER, that any bond, undertaking, recognizance, or suretyship obligation shall be valid and binding upon the Company (i) when signed by the president, any vice president or assistant vice president, and attested and sealed (if a seal be required) by any secretary or assistant secretary; or (ii) when signed by the president, any vice president or assistant vice president, secretary or assistant secretary, and countersigned and sealed (if a seal be required) by a duly authorized attorney-in-fact or agent; or (iii) when duly executed and sealed (if a seal be required) by one or more attorneys-in-fact or agents pursuant to and within the limits of the authority evidenced by the Power of Attorney issued by the company to such person or persons.

RESOLVED FURTHER, that the signature of any authorized officer and the seal of the company may be affixed by facsimile to any Power of Attorney or certification thereof authorizing the execution and delivery of any bond, undertaking, recognizance, or other suretyship obligations of the company; and such signature and seal when so used shall have the same force and effect as though manually affixed.

IN WITNESS WHEREOF, OLD REPUBLIC SURETY COMPANY has caused these presents to be signed by its proper officer, and its corporate seal to be affixed this 22ND day of MAY, 2014.

OLD REPUBLIC SURETY COMPANY

Phyllis M. Johnson
Assistant Secretary



Alan Pavlic
President

STATE OF WISCONSIN, COUNTY OF WAUKESHA-SS

On this 22ND day of MAY, 2014, personally came before me, Alan Pavlic and Phyllis M. Johnson, to me known to be the individuals and officers of the OLD REPUBLIC SURETY COMPANY who executed the above instrument, and they each acknowledged the execution of the same, and being by me duly sworn, did severally depose and say; that they are the said officers of the corporation aforesaid, and that the seal affixed to the above instrument is the seal of the corporation, and that said corporate seal and their signatures as such officers were duly affixed and subscribed to the said instrument by the authority of the board of directors of said corporation.



Kathryn R. Pearson
Notary Public
My commission expires: 9/28/2014

(Expiration of notary commission does not invalidate this instrument)

CERTIFICATE

I, the undersigned, assistant secretary of the OLD REPUBLIC SURETY COMPANY, a Wisconsin corporation, CERTIFY that the foregoing and attached Power of Attorney remains in full force and has not been revoked; and furthermore, that the Resolutions of the board of directors set forth in the Power of Attorney, are now in force.

40-2714



Signed and sealed at the City of Brookfield, WI this 25TH day of MAY, 2016

James E. Cherny
Assistant Secretary

CALLENDER & CO.

THIS DOCUMENT HAS A COLORED BACKGROUND AND IS MULTI-COLORED ON THE FACE. THE COMPANY LOGO APPEARS ON THE BACK OF THIS DOCUMENT AS A WATERMARK. IF THESE FEATURES ARE ABSENT THIS DOCUMENT IS VOID

STATE OF ILLINOIS
CITY OF PEORIA

NOTICE TO CONTRACTORS

1. Time and Place of Opening Bids.

Sealed proposals for the improvement described herein will be received at the Office of the City Engineer, Public Works Facility, 3505 N. Dries Lane, Peoria, Illinois, until **11:00 A.M., Thursday, April 28, 2016** and at that time publicly opened and read.

2. Description of Work.

(A) Proposed improvement is officially known as **SIDEWALK PARTICIPATION PROGRAM 2016.**

(B) The proposed improvement consists of removing existing sidewalk, curb, curb and gutter, driveways, and driveway approaches and replacing with new sidewalk, curb, driveway, driveway approaches, curb and gutter, ADA Ramps and all necessary adjustments, incidentals and appurtenances.

3. Instructions to Bidders.

(A) Plans, proposal forms, and specifications for said proposed project may be examined at the Offices of the City Engineer, Public Works Facility, 3505 North Dries Lane, Peoria, IL. Before plans and specifications may be obtained, contractors must be pre-qualified. Complete sets of plans and proposal forms may be obtained on CD at no charge; contact information must be given in exchange for the CD. Each business may receive one CD at no-cost, or request an electronic plan set by email to pwdropbox@peoriagov.org.

(B) All proposals must be accompanied by a proposal guaranty as provided in Section 102 of the "Standard Specifications for Road and Bridge Construction" prepared by the Illinois Department of Transportation: a Bid Bond, or a proposal guarantee of cash, a Bank Cashier Check, or a properly certified check made payable to the City of Peoria, for not less than five percent (5%) of the amount of the bid.

(C) The Schedule of Prices shows the breakdown of quantities by sidewalk program. The total price for each pay item will be based on the Total Contract Quantity.

4. Rejection of Bids.

The City of Peoria reserves the right to reject any or all proposals as provided in LRS6 of the "Supplemental Specifications and Recurring Special Provisions" prepared by the Department of Transportation of the State of Illinois, adopted January 1, 2012, and last amended on April 1, 2016.

STATE OF ILLINOIS
CITY OF PEORIA

PROPOSAL

1. Proposal of HOROWITZ CONCRETE
i. (Name and Address of Bidder)

For the improvement, designated in Paragraph 2 below, by the construction of sidewalk, combination curb and sidewalk, combination curb and gutter, curb, gutter flag, driveway pavement, ADA access ramps and adjustments are to be improved.

2. The contract documents for the proposed improvements are those prepared the City of Peoria Engineering Department and approved in March 2016 which contract documents are designated as City-wide SIDEWALK PARTICIPATION PROGRAM 2016
3. The specifications herein referred to are the "Standard Specifications for Road and Bridge Construction," prepared by the Department of Transportation of the State of Illinois and adopted by said Department on January 1, 2012. The undersigned agrees to accept, as part of the contract, the Special Provisions contained within this proposal.
4. The undersigned declares that he will comply with the applicable provisions of Section 100, General Requirements and Covenants.
5. The undersigned agrees to complete the work, by November 18, 2016 unless additional time is granted in accordance with Article 108.08 of the Specifications.
6. Accompanying this proposal is a bid bond, certified check, or cashier's check complying with the requirements of the Specifications, made payable to the City Treasurer of the City of Peoria, Illinois. If this proposal is accepted and the undersigned fails to execute a contract and contract bond as required, it is hereby agreed that the check shall be forfeited to the awarding authority.

The amount of the check or draft is \$ Red KOND.

Attach Cashier's Check or Certified Check Here

7. The undersigned certifies that it is not delinquent in the payment of any indebtedness, tax, fee or fine owed to the City of Peoria, or in the payment of any tax administered by the Illinois Department of Revenue, and is in compliance with the terms and conditions of Sec. 10-109 of the Peoria City Code and 65 ILCS 5/11-42.1-1.
8. Each pay item shall have a unit price and a total price.
9. The unit price shall govern if no total price is shown or if there is a discrepancy between the product of the unit price multiplied by the quantity.
10. If a unit price is omitted, the total price will be divided by the quantity in order to establish a unit price.
11. A bid will be declared unacceptable if neither a unit price nor a total price is shown.
12. The undersigned firm certifies that it has not been convicted of bribery or attempting to bribe an officer or employee of the City of Peoria, nor has the firm made an admission of guilt of such conduct which is a matter of record, nor has an official, agent, or employee of the firm committed bribery or attempted bribery on behalf of the firm and pursuant to the direction or authorization of a responsible official of the firm. The undersigned firm further certifies that it is not barred from contracting with any unit of Federal, State or local government as a result of a violation of State laws prohibiting bid-rigging or bid-rotating and has not been suspended or debarred from receiving federal funding.
13. EMPLOYEE/EMPLOYMENT RESTRICTIONS – THE CONTRACTOR:

THE CONTRACTOR, (hereinafter referred to as “SERVICE PROVIDER”) agrees, as a condition of accepting this contract with the City of Peoria, that, for a period of one (1) year following completion of this contract, it shall be prohibited from hiring, directly or indirectly, any City employee or official who was involved, directly or indirectly in: (1) the selection and/or recommendation to select the SERVICE PROVIDER for performance of this contract; (2) coordinating the efforts of the SERVICE PROVIDER in the consummation or completion of this contract; or (3) monitoring or determining the performance of the SERVICE PROVIDER. The SERVICE PROVIDER further acknowledges and agrees that, upon the City’s determination that a violation of this provision has occurred, the penalty imposed, at the sole discretion of the City, may include one or more of the following: (1) cancellation of any other contract(s) between the City of Peoria and the SERVICE PROVIDER; (2) disqualification of the SERVICE PROVIDER from bidding or being awarded future contracts with the City of Peoria for a period of two [2] years; and/or (3) payment of liquidated damages to the City of Peoria in the amount of TWENTY FIVE THOUSAND DOLLARS (\$25,000.00).

This does not apply to any City Employee involved in the 2011-12 reduction in force; nor does it apply to parties taking the Early Retirement incentive offered by the City from November 1, 2011 through November 1, 2012.

14. EEO CERTIFICATION* (Check one):

We are presently applying for the EEO Certification. Employer Report Form (Form CC-1) is completed and enclosed.

Presently, we have the Employer Report Form (Form CC-1) on file with the City of Peoria, Office of Equal Opportunity and have a current Certificate of Compliance Number.

Certificate of Compliance Number: 02629

**Please note there is a \$50.00 processing fee for new and renewal certification requests.*

15. The City of Peoria can increase or decrease this contract up to 25% to meet its budgetary needs.
16. The undersigned submits herewith this Schedules of Prices covering the work to be performed under this contract:

City Of Peoria
 Department of Public Works
 Schedule of Prices
 Project: Sidewalk Participation - 2016



	ITEM	QUANTITY		UNIT PRICE	AMOUNT
20200100	Earth Excavation	125	C.Y.	40	5,000
20201200	Removal and Disposal of Unsuitable Materials	25	C.Y.	40	1,000
31101000	Subbase Granular Materials, Type B	185	TONS	25	4625
42300200	P.C.C. Driveway Pavement, 6"	630	S.Y.	85	53,550
42300400	P.C.C. Driveway Pavement, 8"	230	S.Y.	88	20,240
42400100	P.C.C. Sidewalk, 4"	8,200	S.F.	6.50	53,300
42400800	Detectable Warnings	130	S.F.	25	3,250
44000200	Driveway Pavement Removal	950	S.Y.	18	17,100
44000300	Curb Removal	890	FT.	10	8,900
44000500	Combination Concrete Curb and Gutter Removal	2,075	FT.	10	20,750
44000600	Sidewalk Removal	8,200	S.F.	2.00	16,400
60600605	Concrete Curb, Type B	945	FT.	35	33,075
20100210	Tree Removal, Over 15 Units Diameter	50	UNIT	50	2,500
X6060000	Combination Concrete Curb and Gutter, Width Varies	2,050	FT.	45	92,250
X4080052	Incidental Hot-Mix Surfacing (Special)	3,500	S.F.	10	35,000
X4240010	P.C.C. Combination Curb and Sidewalk, 4"	2,700	S.F.	9	24,300
X4400550	Combination Curb and Sidewalk Removal	2,700	S.F.	3.00	8,100
X2110000	Topsoil, Compost & Mulch F&P	40	TONS	50	2,000
X0000001	Relocate Existing Retaining Walls	25	S.F.	30	750
X0000002	Concrete Steps	30	S.F.	50	1,500
X0000003	Brick Sidewalk Removal	300	S.F.	2.00	600
X0000004	Concrete Step Removal	30	S.F.	10	300

Contractor's Proposal to Make All Improvements: 404,490 -

The undersigned further agrees that if awarded the contract for the sections contained in the following combinations, he will perform the work in accordance with the requirements of each individual proposal for the multiple bid specified in the schedule below.

(If an individual) Signature of Bidder _____

Business Address _____

(If a partnership) Firm Name _____

Signed by _____
President

Business Address _____

Insert Names _____
and Addresses _____
of all partners: _____

(If a corporation) Corporate Name HORWITZ CONCRETE

Signed by *[Signature]*

Business Address 128 LEGION LN.
E. PEORIA IL

Insert Names of Officers:

DARIN HOROWITZ
President
ANNE HOROWITZ
Secretary
DARIN HOROWITZ
Treasurer

Attest: *[Signature]*
Secretary



Proposal Bid Bond

RETURN WITH BID

Route
Municipality City of Peoria
Rd. Dist./Twnshp
County Peoria
Section

WE HOROWITZ CONCRETE CO., INC

as PRINCIPAL, and OLD REPUBLIC SURETY CO

as SURETY.

are held and firmly bound unto THE CITY OF PEORIA (hereafter referred to as "LA") in the penal sum of 5% of the total bid price, or for the amount specified in Article 102.09 of the "Standard Specifications for Road and Bridge Construction" in effect on the date of invitation for bids. We bind ourselves, our heirs, executors, administrators, successors, and assigns, jointly to pay to the LA this sum under the conditions of this instrument.

WHEREAS THE CONDITION OF THE FOREGOING OBLIGATION IS SUCH that, the said PRINCIPAL is submitting a written proposal to the LA acting through its awarding authority for the construction of the work designated as the above section.

THEREFORE if the proposal is accepted and a contract awarded to the PRINCIPAL by the LA for the above designated section and the PRINCIPAL shall within fifteen (15) days after award enter into a formal contract, furnish surety guaranteeing the faithful performance of the work, and furnish evidence of the required insurance coverage, all as provided in the "Standard Specifications for Road and Bridge Construction" and applicable Supplemental Specifications, then this obligation shall become void; otherwise it shall remain in full force and effect.

IN THE EVENT the LA determines the PRINCIPAL has failed to enter into a formal contract in compliance with any requirements set forth in the preceding paragraph, then the LA acting through its awarding authority shall immediately be entitled to recover the full penal sum set out above, together with all court costs, all attorney fees, and any other expense of recovery.

IN TESTIMONY WHEREOF, the said PRINCIPAL and the said SURETY have caused this instrument to be signed by their respective officers this 26TH day of APRIL A.D. 2016

Principal

(Company Name) HOROWITZ CONCRETE CO., INC. (Company Name)

By: (Signature and Title) DARIN HOROWITZ/PRESIDENT (Signature and Title)

(If PRINCIPAL is a joint venture of two or more contractors, the company names, and authorized signatures of each contractor must be affixed.)

OLD REPUBLIC SURETY CO (Name of Surety) By: JEFFREY A. PETEFISH (Signature of Attorney-in-Fact)

STATE OF ILLINOIS,

COUNTY OF PEORIA

I, PHYLLIS D MALONEY, a Notary Public in and for said county,

do hereby certify that DARIN HOROWITZ AND JEFFREY A PETEFISH (Insert names of individuals signing on behalf of PRINCIPAL & SURETY)

who are each personally known to me to be the same persons whose names are subscribed to the foregoing instrument on behalf of PRINCIPAL and SURETY, appeared before me this day in person and acknowledged respectively, that they signed and delivered said instruments as their free and voluntary act for the uses and purposes therein set forth.

Given under my hand and notarial seal this 26TH day of APRIL A.D. 2016

NOTICE
1. Improper execution of this form (i.e. missing signatures or seals or incomplete certification) will result in bid being declared irregular.
2. If bid bond is used in lieu of proposal guaranty check, it must be on this form and must be submitted with bid

My commission expires 02/24/2018
Phyllis D. Maloney (Notary Public)

OFFICIAL SEAL
PHYLLIS D MALONEY
NOTARY PUBLIC - STATE OF ILLINOIS
MY COMMISSION EXPIRES 2-24-2018

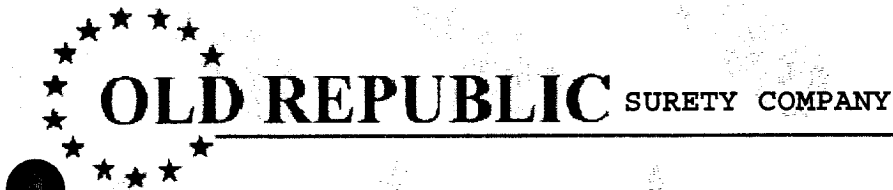

POWER OF ATTORNEY

KNOW ALL MEN BY THESE PRESENTS: That OLD REPUBLIC SURETY COMPANY, a Wisconsin stock insurance corporation, does make, constitute and appoint:

ROBERT D. BIELENBERG, LARRY K. BIELEMA, JEFFREY A. PETEFISH, OF PEORIA, IL

its true and lawful Attorney(s)-in-Fact, with full power and authority, not exceeding \$20,000,000, for and on behalf of the company as surety, to execute and deliver and affix the seal of the company thereto (if a seal is required), bonds, undertakings, recognizances or other written obligations in the nature thereof, (other than bail bonds, bank depository bonds, mortgage deficiency bonds, mortgage guaranty bonds, guarantees of installment paper and note guaranty bonds, self-insurance workers compensation bonds guaranteeing payment of benefits, asbestos abatement contract bonds, waste management bonds, hazardous waste remediation bonds or black lung bonds), as follows:

ALL WRITTEN INSTRUMENTS IN AN AMOUNT NOT TO EXCEED AN AGGREGATE OF FIVE HUNDRED THOUSAND DOLLARS(\$500,000)----- FOR ANY SINGLE OBLIGATION, REGARDLESS OF THE NUMBER OF INSTRUMENTS ISSUED FOR THE OBLIGATION.

and to bind OLD REPUBLIC SURETY COMPANY thereby, and all of the acts of said Attorneys-in-Fact, pursuant to these presents, are ratified and confirmed. This document is not valid unless printed on colored background and is multi-colored. This appointment is made under and by authority of the board of directors at a special meeting held on February 18, 1982. This Power of Attorney is signed and sealed by facsimile under and by the authority of the following resolutions adopted by the board of directors of the OLD REPUBLIC SURETY COMPANY on February 18, 1982.

RESOLVED that, the president, any vice-president, or assistant vice president, in conjunction with the secretary or any assistant secretary, may appoint attorneys-in-fact or agents with authority as defined or limited in the instrument evidencing the appointment in each case, for and on behalf of the company to execute and deliver and affix the seal of the company to bonds, undertakings, recognizances, and suretyship obligations of all kinds; and said officers may remove any such attorney-in-fact or agent and revoke any Power of Attorney previously granted to such person.

RESOLVED FURTHER, that any bond, undertaking, recognizance, or suretyship obligation shall be valid and binding upon the Company (i) when signed by the president, any vice president or assistant vice president, and attested and sealed (if a seal be required) by any secretary or assistant secretary; or (ii) when signed by the president, any vice president or assistant vice president, secretary or assistant secretary, and countersigned and sealed (if a seal be required) by a duly authorized attorney-in-fact or agent; or (iii) when duly executed and sealed (if a seal be required) by one or more attorneys-in-fact or agents pursuant to and within the limits of the authority evidenced by the Power of Attorney issued by the company to such person or persons.

RESOLVED FURTHER, that the signature of any authorized officer and the seal of the company may be affixed by facsimile to any Power of Attorney or certification thereof authorizing the execution and delivery of any bond, undertaking, recognizance, or other suretyship obligations of the company; and such signature and seal when so used shall have the same force and effect as though manually affixed.

IN WITNESS WHEREOF, OLD REPUBLIC SURETY COMPANY has caused these presents to be signed by its proper officer, and its corporate seal to be affixed this 1ST day of MAY, 2014.

OLD REPUBLIC SURETY COMPANY

Phyllis M. Johnson
Assistant Secretary



Alan Pavlic
President

STATE OF WISCONSIN, COUNTY OF WAUKESHA-SS

On this 1ST day of MAY, 2014, personally came before me, Alan Pavlic and Phyllis M. Johnson, to me known to be the individuals and officers of the OLD REPUBLIC SURETY COMPANY who executed the above instrument, and they each acknowledged the execution of the same, and being by me duly sworn, did severally depose and say; that they are the said officers of the corporation aforesaid, and that the seal affixed to the above instrument is the seal of the corporation, and that said corporate seal and their signatures as such officers were duly affixed and subscribed to the said instrument by the authority of the board of directors of said corporation.



Kathryn R. Pearson
Notary Public
My commission expires: 9/28/2014

(Expiration of notary commission does not invalidate this instrument)

CERTIFICATE

I, the undersigned, assistant secretary of the OLD REPUBLIC SURETY COMPANY, a Wisconsin corporation, CERTIFY that the foregoing and attached Power of Attorney remains in full force and has not been revoked; and furthermore, that the Resolutions of the board of directors set forth in the Power of Attorney, are now in force.

40-2714

Signed and sealed at the City of Brookfield, WI this 26TH day of APRIL, 2016.



James E. Peterson
Assistant Secretary

CALLENDER & CO.

THIS DOCUMENT HAS A COLORED BACKGROUND AND IS MULTI-COLORED ON THE FACE. THE COMPANY LOGO APPEARS ON THE BACK OF THIS DOCUMENT AS A WATERMARK. IF THESE FEATURES ARE ABSENT, THIS DOCUMENT IS VOID.



CITY OF PEORIA SUBCONTRACTOR UTILIZATION STATEMENT

Section I (select all that apply)

MBE/WBE Subcontractor(s) will be utilized on this project
 Non MBE/WBE Subcontractor(s) will be utilized on this project

Section II

PRIME CONTRACTOR

PROJECT

Name: HOROWITZ CONCRETE
 Address: 128 LEGION LN. E PEORIA
 Phone: 208 4757
 Contact Person: DARIN
 Email: _____

Name: Sidewalk Participation PGM 2016
 Total Contract Value: _____

Ownership Status: MBE WBE M/WBE Non-M/WBE

Section III: Selected Subcontractors

Subcontractor Name	MBE, WBE or Non M/WBE	Amount	% of Total Contract	Scope of Work
SEARLE	WBE	TO BE DETERMINED		TRUCKING
TOTALS				

**If more than seven firms are utilized, please copy the form and attach the additional information.*

Section IV: Subcontractors that submitted bids but were not selected (M/WBE Only)

Subcontractor Name	Scope of Work Bid	Denial Reason

**If more than seven firms submitted quotes, please copy the form and attach the additional information.*

For Office Use Only

Reviewed by: _____

Section V: Subcontractors Contacted (M/WBE Only)

Subcontractor Name	Method of Contact	Contact Outcome
ATTACHED	WITH LETTER	

**If more than seven firms were contacted, please copy the form and attach the additional information.*

Section VI

The City of Peoria is committed to promoting equal opportunity and has established the following subcontractor utilization goals for city funded construction projects: 10% MBE and 5% WBE. Prime Contractors have an obligation to make a good faith effort to advance the city's commitment to increase diversity among the firms working on city construction projects.

This form must be completed and submitted with bid proposals. ALL subcontractors intended for use on this project shall be listed in Section III above; along with the total amount to be paid to the subcontractors; percentage of total contract; and scope of work. If for whatever reason the prime contractor has to utilize a subcontractor not listed above, they must submit a Notification of Change in Participation.

The undersigned certifies that the information included herein is true and correct; the subcontractors listed above have agreed to perform the scope of work described. The undersigned further certifies that it has no controlling, dominating or conflict of interest in any of the listed subcontractors.

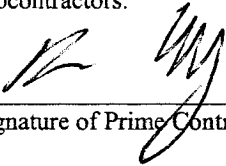

 Signature of Prime Contractor

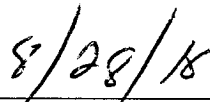

 Date

For Office Use Only
 Reviewed by: _____



128 LEGION LN. • E. PEORIA, IL • 61611 • 309-208-4757

4/17/2016

Horowitz Concrete will be submitting a bid to the City of Peoria , for the Sidewalk Participation project. This is a notice for any subcontractors that would be interested in submitting prices for the project.

Prices must be sent by 4/27/16.

Prices can be emailed or faxed.

darin.horowitz@att.net

309-822-0428

Darin Horowitz



128 LEGION LN. • E. PEORIA, IL • 61611 • 309-208-4757

Date 4/28/16

City of Peoria
Sidewalk participation program project.
Good faith effort.

Contractors contacted,

Buddies landscape emailed , no response.

CJL emailed, no response.

Millenia emailed, no response.

Leo Brown faxed, no response.

Searle emailed, received prices.

TABLE OF CONTENTS

<u>ITEM</u>	<u>PAGE</u>
PROPOSAL ITEMS	
NOTICE TO CONTRACTORS.....	5
PROPOSAL.....	6
SCHEDULE OF PRICES.....	9
SIGNATURE PAGE.....	10
BID BOND.....	11
SUB-CONTRACTOR UTILIZATION STATEMENT.....	12
M/WBE PARTICIPATION WAIVER REQUEST.....	14
GENERAL CONDITIONS	
DESCRIPTION OF WORK.....	16
PROJECT LOCATIONS & QUANT. FOR SIDEWALK PARTICIPATION.....	16
ADDITIONAL WORK, CONTRACTOR RESPONSIBILITIES.....	17
DEFINITION OF TERMS.....	17
FAILURE TO COMPLETE WORK ON TIME.....	18
RESPONSIBILITY FOR DAMAGE CLAIMS.....	18
QUALIFICATION OF CONTRACTORS.....	19
CONTRACTOR'S INSURANCE.....	19
PROOF OF CARRIAGE OF INSURANCE.....	21
GUARANTEE PERIOD.....	21
PROSECUTION AND PROGRESS OF WORK.....	21
EXISTING UNDERGROUND FACILITIES.....	22
COOPERATION WITH UTILITY COMPANIES.....	22
NOTIFICATION OF UTILITIES PRIOR TO CONSTRUCTION.....	22
J.U.L.I.E. SYSTEM.....	22
CERTIFIED PAYROLL REQUIREMENTS.....	23
PREVAILING WAGE PROVISION.....	23
SUBSTANCE ABUSE PREVENTION PROGRAM.....	30
PROTECTION OF THE PUBLIC.....	30
ITEMS DESIGNATED OR REMOVAL AND EXCAVATION.....	30
CITY SIGNS.....	30
BRICK REPAIRS.....	31
TRAFFIC CONTROL & PROTECTION.....	31
DAMAGE TO EXISTING TREES.....	32
VAULTS.....	32
SAWCUTTING.....	32
CONTACT PERSON.....	32
EQUAL OPPORTUNITY REQUIREMENTS	
EEO CONTRACT COMPLIANCE CLAUSE.....	34
REQUIREMENTS FOR GOOD FAITH EFFORTS.....	36
HUMAN RIGHTS ACT.....	43
ROADWORK SPECIAL PROVISIONS	
SALVAGING EXISTING MATERIAL.....	45
CONSTRUCTION DEBRIS.....	45
EROSION CONTROL.....	45
EARTH EXCAVATION.....	46

COMBINATION CURB AND SIDEWALK REMOVAL, SIDEWALK REMOVAL.....	46
DRIVEWAY PAVEMENT REMOVAL, PAVEMENT REMOVAL	46
BRICK SIDEWALK REMOVAL.....	47
CURB REMOVAL, COMBINATION CURB & GUTTER REMOVAL.....	47
CONCRETE STEP REMOVAL	47
SUBBASE GRANULAR MATERIAL	48
REMOVAL & DISPOSAL OF UNSUITABLE MATERIAL	48
CONCRETE CURB, TYPE B	48
P.C.C. COMBINATION CURB AND SIDEWALK.....	49
P.C.C. SIDEWALK, 4"	49
P.C.C. DRIVEWAY PAVEMENT, 6" & 8"	49
COMBINATION CONCRETE CURB & GUTTER	49
CONCRETE STEPS.....	50
INCIDENTAL HOT MIX ASPHALT SURFACING, SPECIAL	50
CURING COMPOUND	51
CONCRETE FIBERS.....	51
SEEDING & MULCHING.....	51
SIDEWALK RAMPS FOR THE DISABLED	51
DETECTABLE WARNINGS	52
TIE BARS & DOWEL BARS.....	53
TOPSOIL, COMPOST & MULCH, F&P, SPECIAL	53
RELOCATE EXISTING RETAINING WALL	53
TREE REMOVAL, OVER 15 UNITS	54

APPENDIX A

EEO DOCUMENTS

EMPLOYER REPORT CC-1	57
MINORITY AND WOMEN BUSINESS ENTERPRISE DIRECTORY	58
EQUAL EMPLOYMENT OPPORTUNITY	58
MINORITY AND FEMALE WORKFORCE UTILIZATION	58

CONTRACT DELIVERABLES

SUBCONTRACTOR PAYMENT FORM.....	60
MONTHLY WORKFORCE ANALYSIS.....	61
NOTIFICATION OF CHANGE IN PARTICIPATION	62

MISCELLANEOUS

SAMPLE CONTRACT	64
-----------------------	----

STANDARDS..... PAGE

CURB RAMPS FOR SIDEWALK.....	65-72
CONCRETE CURB TYPE B & COMBINATION CURB & GUTTER.....	73-74
COMBINATION CONCRETE, CURB & SIDEWALK, 4"	75
TRAFFIC CONTROL DETAILS.....	76-93
P.C.C. SIDEWALK, 4"	94
P.C.C. STEPS	95
P.C.C. DRIVEWAY PAVEMENT	96-97
P.C.C. ALLEY APPROACH.....	98-99
BRICK REPLACEMENT ADJACENT TO CURB OR GUTTER	100

PROPOSAL ITEMS

STATE OF ILLINOIS
CITY OF PEORIA

NOTICE TO CONTRACTORS

1. Time and Place of Opening Bids.

Sealed proposals for the improvement described herein will be received at the Office of the City Engineer, Public Works Facility, 3505 N. Dries Lane, Peoria, Illinois, until **11:00 A.M., Thursday, April 28, 2016** and at that time publicly opened and read.

2. Description of Work.

(A) Proposed improvement is officially known as **SIDEWALK PARTICIPATION PROGRAM 2016.**

(B) The proposed improvement consists of removing existing sidewalk, curb, curb and gutter, driveways, and driveway approaches and replacing with new sidewalk, curb, driveway, driveway approaches, curb and gutter, ADA Ramps and all necessary adjustments, incidentals and appurtenances.

3. Instructions to Bidders.

(A) Plans, proposal forms, and specifications for said proposed project may be examined at the Offices of the City Engineer, Public Works Facility, 3505 North Dries Lane, Peoria, IL. Before plans and specifications may be obtained, contractors must be pre-qualified. Complete sets of plans and proposal forms may be obtained on CD at no charge; contact information must be given in exchange for the CD. Each business may receive one CD at no-cost, or request an electronic plan set by email to pwdropbox@peoriagov.org .

(B) All proposals must be accompanied by a proposal guaranty as provided in Section 102 of the "Standard Specifications for Road and Bridge Construction" prepared by the Illinois Department of Transportation: a Bid Bond, or a proposal guarantee of cash, a Bank Cashier Check, or a properly certified check made payable to the City of Peoria, for not less than five percent (5%) of the amount of the bid.

(C) The Schedule of Prices shows the breakdown of quantities by sidewalk program. The total price for each pay item will be based on the Total Contract Quantity.

4. Rejection of Bids.

The City of Peoria reserves the right to reject any or all proposals as provided in LRS6 of the "Supplemental Specifications and Recurring Special Provisions" prepared by the Department of Transportation of the State of Illinois, adopted January 1, 2012, and last amended on April 1, 2016.

STATE OF ILLINOIS
CITY OF PEORIA

PROPOSAL

1. Proposal of _____
i. (Name and Address of Bidder)
For the improvement, designated in Paragraph 2 below, by the construction of sidewalk, combination curb and sidewalk, combination curb and gutter, curb, gutter flag, driveway pavement, ADA access ramps and adjustments are to be improved.
2. The contract documents for the proposed improvements are those prepared the City of Peoria Engineering Department and approved in March 2016 which contract documents are designated as City-wide SIDEWALK PARTICIPATION PROGRAM 2016
3. The specifications herein referred to are the "Standard Specifications for Road and Bridge Construction," prepared by the Department of Transportation of the State of Illinois and adopted by said Department on January 1, 2012. The undersigned agrees to accept, as part of the contract, the Special Provisions contained within this proposal.
4. The undersigned declares that he will comply with the applicable provisions of Section 100, General Requirements and Covenants.
5. The undersigned agrees to complete the work, by November 18, 2016 unless additional time is granted in accordance with Article 108.08 of the Specifications.
6. Accompanying this proposal is a bid bond, certified check, or cashier's check complying with the requirements of the Specifications, made payable to the City Treasurer of the City of Peoria, Illinois. If this proposal is accepted and the undersigned fails to execute a contract and contract bond as required, it is hereby agreed that the check shall be forfeited to the awarding authority.

The amount of the check or draft is \$_____.

Attach Cashier's Check or Certified Check Here

7. The undersigned certifies that it is not delinquent in the payment of any indebtedness, tax, fee or fine owed to the City of Peoria, or in the payment of any tax administered by the Illinois Department of Revenue, and is in compliance with the terms and conditions of Sec. 10-109 of the Peoria City Code and 65 ILCS 5/11-42.1-1.
8. Each pay item shall have a unit price and a total price.
9. The unit price shall govern if no total price is shown or if there is a discrepancy between the product of the unit price multiplied by the quantity.
10. If a unit price is omitted, the total price will be divided by the quantity in order to establish a unit price.
11. A bid will be declared unacceptable if neither a unit price nor a total price is shown.
12. The undersigned firm certifies that it has not been convicted of bribery or attempting to bribe an officer or employee of the City of Peoria, nor has the firm made an admission of guilt of such conduct which is a matter of record, nor has an official, agent, or employee of the firm committed bribery or attempted bribery on behalf of the firm and pursuant to the direction or authorization of a responsible official of the firm. The undersigned firm further certifies that it is not barred from contracting with any unit of Federal, State or local government as a result of a violation of State laws prohibiting bid-rigging or bid rotating and has not been suspended or debarred from receiving federal funding.
13. EMPLOYEE/EMPLOYMENT RESTRICTIONS – THE CONTRACTOR:

THE CONTRACTOR, (hereinafter referred to as “SERVICE PROVIDER”) agrees, as a condition of accepting this contract with the City of Peoria, that, for a period of one (1) year following completion of this contract, it shall be prohibited from hiring, directly or indirectly, any City employee or official who was involved, directly or indirectly in: (1) the selection and/or recommendation to select the SERVICE PROVIDER for performance of this contract; (2) coordinating the efforts of the SERVICE PROVIDER in the consummation or completion of this contract; or (3) monitoring or determining the performance of the SERVICE PROVIDER. The SERVICE PROVIDER further acknowledges and agrees that, upon the City’s determination that a violation of this provision has occurred, the penalty imposed, at the sole discretion of the City, may include one or more of the following: (1) cancellation of any other contract(s) between the City of Peoria and the SERVICE PROVIDER; (2) disqualification of the SERVICE PROVIDER from bidding or being awarded future contracts with the City of Peoria for a period of two [2] years; and/or (3) payment of liquidated damages to the City of Peoria in the amount of TWENTY FIVE THOUSAND DOLLARS (\$25,000.00).

This does not apply to any City Employee involved in the 2011-12 reduction in force; nor does it apply to parties taking the Early Retirement incentive offered by the City from November 1, 2011 through November 1, 2012.

14. EEO CERTIFICATION* (Check one):

We are presently applying for the EEO Certification. Employer Report Form (Form CC-1) is completed and enclosed.

Presently, we have the Employer Report Form (Form CC-1) on file with the City of Peoria, Office of Equal Opportunity and have a current Certificate of Compliance Number.

Certificate of Compliance Number: _____

**Please note there is a \$50.00 processing fee for new and renewal certification requests.*

15. The City of Peoria can increase or decrease this contract up to 25% to meet its budgetary needs.

16. The undersigned submits herewith this Schedules of Prices covering the work to be performed under this contract:

City Of Peoria
Department of Public Works
Schedule of Prices
Project: Sidewalk Participation - 2016



	<u>ITEM</u>	<u>QUANTITY</u>		<u>UNIT PRICE</u>	<u>AMOUNT</u>
20200100	Earth Excavation	125	C.Y.		
20201200	Removal and Disposal of Unsuitable Materials	25	C.Y.		
31101000	Subbase Granular Materials, Type B	185	TONS		
42300200	P.C.C. Driveway Pavement, 6"	630	S.Y.		
42300400	P.C.C. Driveway Pavement, 8"	230	S.Y.		
42400100	P.C.C. Sidewalk, 4"	8,200	S.F.		
42400800	Detectable Warnings	130	S.F.		
44000200	Driveway Pavement Removal	950	S.Y.		
44000300	Curb Removal	890	FT.		
44000500	Combination Concrete Curb and Gutter Removal	2,075	FT.		
44000600	Sidewalk Removal	8,200	S.F.		
60600605	Concrete Curb, Type B	945	FT.		
20100210	Tree Removal, Over 15 Units Diameter	50	UNIT		
X6060000	Combination Concrete Curb and Gutter, Width Varies	2,050	FT.		
X4080052	Incidental Hot-Mix Surfacing (Special)	3,500	S.F.		
X4240010	P.C.C. Combination Curb and Sidewalk, 4"	2,700	S.F.		
X4400550	Combination Curb and Sidewalk Removal	2,700	S.F.		
X2110000	Topsoil, Compost & Mulch F&P	40	TONS		
X0000001	Relocate Existing Retaining Walls	25	S.F.		
X0000002	Concrete Steps	30	S.F.		
X0000003	Brick Sidewalk Removal	300	S.F.		
X0000004	Concrete Step Removal	30	S.F.		

Contractor's Proposal to Make All Improvements:

The undersigned further agrees that if awarded the contract for the sections contained in the following combinations, he will perform the work in accordance with the requirements of each individual proposal for the multiple bid specified in the schedule below.

(If an individual) Signature of Bidder _____

Business Address _____

(If a partnership) Firm Name _____

Signed by _____
President

Business Address _____

Insert Names _____
and Addresses _____
of all partners: _____

(If a corporation) Corporate Name _____

Signed by _____

Business Address _____

Insert Names
of Officers:

President

Secretary

Treasurer

Attest: _____
Secretary



Proposal Bid Bond

RETURN WITH BID

Route _____
 Municipality City of Peoria
 Rd. Dist./Twnshp _____
 County Peoria
 Section _____

WE _____
 _____ as PRINCIPAL, an _____
 _____ as SURETY,

are held and firmly bound unto THE CITY OF PEORIA (hereafter referred to as "LA") in the penal sum of 5% of the total bid price, or for the amount specified in Article 102.09 of the "Standard Specifications for Road and Bridge Construction" in effect on the date of invitation for bids. We bind ourselves, our heirs, executors, administrators, successors, and assigns, jointly to pay to the LA this sum under the conditions of this instrument.

WHEREAS THE CONDITION OF THE FOREGOING OBLIGATION IS SUCH that, the said PRINCIPAL is submitting a written proposal to the LA acting through its awarding authority for the construction of the work designated as the above section.

THEREFORE if the proposal is accepted and a contract awarded to the PRINCIPAL by the LA for the above designated section and the PRINCIPAL shall within fifteen (15) days after award enter into a formal contract, furnish surety guaranteeing the faithful performance of the work, and furnish evidence of the required insurance coverage, all as provided in the "Standard Specifications for Road and Bridge Construction" and applicable Supplemental Specifications, then this obligation shall become void; otherwise it shall remain in full force and effect.

IN THE EVENT the LA determines the PRINCIPAL has failed to enter into a formal contract in compliance with any requirements set forth in the preceding paragraph, then the LA acting through its awarding authority shall immediately be entitled to recover the full penal sum set out above, together with all court costs, all attorney fees, and any other expense of recovery.

IN TESTIMONY WHEREOF, the said PRINCIPAL and the said SURETY have caused this instrument to be signed by their respective officers this _____ day of _____ A.D. _____

Principal

 (Company Name) _____ (Company Name)
 By: _____ By: _____
 (Signature and Title) (Signature and Title)

(If PRINCIPAL is a joint venture of two or more contractors, the company names, and authorized signatures of each contractor must be affixed.)

Surety

 (Name of Surety) By: _____
 (Signature of Attorney-in-Fact)

STATE OF ILLINOIS,

COUNTY OF _____

I, _____, a Notary Public in and for said county,

do hereby certify that _____
 (Insert names of individuals signing on behalf of PRINCIPAL & SURETY)

who are each personally known to me to be the same persons whose names are subscribed to the foregoing instrument on behalf of PRINCIPAL and SURETY, appeared before me this day in person and acknowledged respectively, that they signed and delivered said instruments as their free and voluntary act for the uses and purposes therein set forth.

Given under my hand and notarial seal this _____ day of _____ A.D. _____

NOTICE

1. Improper execution of this form (i.e. missing signatures or seals or incomplete certification) will result in bid being declared irregular.
2. If bid bond is used in lieu of proposal guaranty check, it must be on this form and must be submitted with bid

My commission expires _____

 (Notary Public)



CITY OF PEORIA SUBCONTRACTOR UTILIZATION STATEMENT

Section I (*select all that apply*)

MBE/WBE Subcontractor(s) will be utilized on this project
 Non MBE/WBE Subcontractor(s) will be utilized on this project

Section II
PRIME CONTRACTOR

Name: _____
 Address: _____
 Phone: _____
 Contact Person: _____
 Email: _____
 Ownership Status: MBE WBE M/WBE Non-M/WBE

PROJECT

Name: _____
 Total Contract Value: _____

Section III: Selected Subcontractors

Subcontractor Name	MBE, WBE or Non M/WBE	Amount	% of Total Contract	Scope of Work
TOTALS				

**If more than seven firms are utilized, please copy the form and attach the additional information.*

Section IV: Subcontractors that submitted bids but were not selected (M/WBE Only)

Subcontractor Name	Scope of Work Bid	Denial Reason

**If more than seven firms submitted quotes, please copy the form and attach the additional information.*

For Office Use Only
 Reviewed by: _____

Section V: Subcontractors Contacted (M/WBE Only)

Subcontractor Name	Method of Contact	Contact Outcome

**If more than seven firms were contacted, please copy the form and attach the additional information.*

Section VI

The City of Peoria is committed to promoting equal opportunity and has established the following subcontractor utilization goals for city funded construction projects: 10% MBE and 5% WBE. Prime Contractors have an obligation to make a good faith effort to advance the city's commitment to increase diversity among the firms working on city construction projects.

This form must be completed and submitted with bid proposals. ALL subcontractors intended for use on this project shall be listed in Section III above; along with the total amount to be paid to the subcontractors; percentage of total contract; and scope of work. If for whatever reason the prime contractor has to utilize a subcontractor not listed above, they must submit a Notification of Change in Participation.

The undersigned certifies that the information included herein is true and correct; the subcontractors listed above have agreed to perform the scope of work described. The undersigned further certifies that it has no controlling, dominating or conflict of interest in any of the listed subcontractors.

Signature of Prime Contractor

Date

For Office Use Only
Reviewed by: _____

**CITY OF PEORIA
M/WBE PARTICIPATION WAIVER REQUEST**

PRIME CONTRACTOR

Name: _____

Address: _____

Phone: _____

Contact Person: _____

PROJECT

Name: _____

We hereby request to waive all of the MBE and WBE participation goals on the above named project and self-perform all work for the following reason(s). The firm further affirms that the stated reasons and documents provided are true and correct and not misleading: **(CHECK ALL THAT APPLY. SPECIFIC SUPPORTING DOCUMENTATION MUST BE SUBMITTED WHERE INDICATED.)**

1. No MBEs/WBEs responded to our invitation to bid. _____
2. No subcontracting opportunities exist. (Attach explanation) _____
3. The award of subcontract(s) is impracticable. (Attach explanation) _____

SIGNED: _____
(Company Official)

DATE: _____

FOR OFFICE USE ONLY

APPROVED

DISAPPROVED

REVIEWED BY _____

DATE _____

GENERAL CONDITIONS

STATE OF ILLINOIS
CITY OF PEORIA

SPECIAL PROVISIONS

The following Special Provisions supplement the "Standard Specifications for Road and Bridge Construction," adopted January 1, 2012, the "Supplemental Specifications and Recurring Special Provisions", adopted April 1, 2016, and the latest edition of the "Illinois Manual on Uniform Traffic Control Devices for Streets and Highways" in effect on the date of invitation for bids, the "Standard Specifications for Traffic Control Items," adopted January 1, 2002, included herein which apply to and govern the construction of the SIDEWALK PARTICIPATION PROGRAM 2016, in the City of Peoria, Peoria County, and in case of conflict with any part of said specifications, the said Special Provisions shall take precedence and shall govern.

DESCRIPTION OF WORK

The SIDEWALK PARTICIPATION PROGRAM 2016 proposed improvement consists of reconstructing Portland cement sidewalks, driveways, curb and gutter, ADA Ramps, and permeable pavers on public sidewalks.

PROJECT LOCATIONS & QUANTITIES FOR SIDEWALK PARTICIPATION

The locations for the SIDEWALK PARTICIPATION PROGRAM 2016 have been requested by the property owner. There could be 80-100 properties served by this program, dependent on amount of work per property-relative to the maximum budget.

The City will accept property owner requests & complaints until July for the SIDEWALK PARTICIPATION PROGRAM 2016 unless room is still available for additional properties.

The properties were surveyed, measured, & quantified for inclusion in this set of bid documents. The property owners have been mailed a letter, application, and estimate for the work to be completed. In order to be included in the program, property owners must submit their signed application and a check by early May 2016. Based on previous years, it is anticipated that 70% of the properties, who were sent an application, will participate. At this time, it is unknown which properties will or will not participate.

It is anticipated that a pre-construction meeting will be held around mid-May, 2016 which will allow for construction to begin shortly thereafter. The contractor will receive a list of all the properties that have submitted applications and payment that will be participating in the program at the preconstruction meeting.

Additional properties will be added to the list to take the place of the properties that chose not to participate. These properties will be property owner requests that are submitted from March to August 2016. The City will do its best to keep the types and sizes of the new properties similar to those removed.

The Contractor shall work with the City to develop weekly schedules for the City to show where work will be performed in the coming week. The City shall use this information to coordinate

informing property owners of upcoming driveway closures and other work.

ADDITIONAL WORK, CONTRACTOR RESPONSIBILITY

The Contractor shall be responsible for coordinating additional work with a property owner. Additional work shall be defined as any work requested by the property owner that was not originally planned by the City or its Consultant. Typical forms of additional work will be driveway approaches and adjustments beyond the limits of the City's planned improvements, privacy walks between the sidewalk and curb; private walks and steps behind the sidewalk, private tree trimming/removal; replacement of private retaining wall not otherwise damaged by contractor, and replacement of sidewalk, curb, or other items that were not agreed upon by the City.

The city will also participate in private walk & step adjustments as needed up to 5 feet in the front and back of the sidewalk. Any additional items needed or requested by the property will be considered additional work.

The respective property owner shall bear the financial responsibility for any additional work as defined above. It is the contractor's responsibility to negotiate and establish an agreed price with any property owner where additional work is required. The city has no obligation, financial or otherwise, as it pertains to additional work.

DEFINITION OF TERMS

Section 101 of the Standard Specifications shall be revised as follows:

Article 101.14 Department. The City of Peoria or its Representative.

Article 101.16 Engineer. The designated employee or representative of the City of Peoria.

The Engineer will not be responsible for construction means, methods, techniques, sequences, or procedures, or for safety precautions and programs.

Article 101.19 Inspector. The authorized representative of the Engineer assigned to make detailed observations or any or all portions of the work or material therefore.

This activity is not to be interpreted as an inspection service, a construction supervision service, or a guaranteeing of the Contractor's performance. The Inspector will not be responsible for construction means, methods, techniques, sequences, or procedures, or for safety precautions and programs. The Inspector will not be responsible for the Contractor's obligation to carry out the work in accordance with the Contract Documents.

FAILURE TO COMPLETE WORK ON TIME

Should the Contractor fail to complete the work by **November 18, 2016**, the Contractor shall be liable to the City of Peoria at a rate of \$750.00 per day for every day worked over the contract time to cover all costs incurred for engineering, inspection and other expenses incurred by the City of Peoria by reason of the Contractor's failure to complete the work within the specified time, and such amount shall be deducted from the monies due the Contractor, not as a penalty, but as damages sustained.

RESPONSIBILITY FOR DAMAGE CLAIMS

The Contractor shall indemnify and save harmless the CITY OF PEORIA, its officers, agents, and employees against all loss, damage or expense that it or they may sustain as a result of any suits, actions, or claims of any character brought on account of injury to or death of any person or persons, including all persons performing any work under this contract, which may arise in any way (except for a negligent act of the City of Peoria, its officers or employees) in connection with the work to be performed under this contract, including but not limited to, suits, actions or claims arising under "An Act providing for the protection and safety of persons in and about the construction, repairing, alteration or removal of building, bridges, viaducts, and other structures, and to provide for the enforcement thereof," approved June 3, 1907, (740 ILCS 150/1), as amended: the Contractor shall also indemnify and save harmless the CITY OF PEORIA, its officers and employees, from all suits, actions, or claims of any character brought because of any injuries or damages received or sustained by any person, persons, or property, on account of, or in consequence of, any neglect by Contractor or a Subcontractor in safeguarding the work; or through use of unacceptable materials in constructing the work; or because of any act or omission, neglect, or misconduct of said Contractor; or because of any claims or amounts recovered for any infringements of patent, trademark, or copyright, or from any claims or amounts arising or recovered under the "Workers Compensation Act," or any other law, ordinance, order, or decree, and so much of the money due the said Contractor under and by virtue of his contract as shall be considered necessary by the Department for such purposes, may be retained for the use of the ENGINEERING DIVISION; or, in case no money is due, his surety shall be held until such suits, actions, or claims have been settled and suitable evidence to that effect furnished to the Department.

QUALIFICATION OF CONTRACTORS

Contractors shall be qualified before plans and proposal documents will be provided for bidding. In general, contractors qualified by the State of Illinois, Department of Transportation to perform the work indicated in the proposal will be acceptable to the City of Peoria, Engineering Division; but, the City Engineer reserves the right to refuse to accept a bid from a State-qualified contractor and will state his reasons, in writing, for said refusal if requested by the contractor.

Contractors who have done similar work and an improvement of similar size for the City in the past normally are qualified by their past performances.

Contractors not qualified as indicated above shall be required to submit a listing of jobs of a similar nature with an indication of the dollar value of said jobs and the person or company for whom the work was performed so that a check of the quality of the work can be made, as well as the performance and financial ability of the contractor. The City Engineer will approve or disapprove the contractor, and the decision shall be final. If desired by the contractor, the City Engineer will provide his reasons for disapproving any contractor from bidding on the proposed improvement.

CONTRACTOR'S INSURANCE

The Contractor shall not commence work under this project until he has obtained all insurance required under this paragraph and such insurance has been approved by the City of Peoria, nor shall the Contractor allow any Subcontractor to commence work on his subcontract until all similar insurance required of the Subcontractor has been so obtained and approved by the City of Peoria.

The Contractor shall require Subcontractors, if any, not protected under the Contractor's insurance policies as an additional insured to take out and maintain insurance of such nature in amounts not less than that required of the principal Contractor, excluding Umbrella Coverage and Owner's Protective Liability and Property Damage Insurance, and any and all insurance obtained by any Subcontractor or Subcontractors shall be approved by the City of Peoria.

All policies shall contain provisions to the effect that in the event of payment of any loss or damage the insurers will have no rights of recovery against any of the insured or additional insureds there under.

COMPENSATION INSURANCE

The Contractor shall take out and maintain during the life of this project Worker's Compensation Insurance for all of his employees employed at the site of the project and, in case any work is sublet, the Contractor shall require the Subcontractor similarly to provide Worker's Compensation Insurance for all of the latter's employees unless such employees are covered by the protection afforded by the Contractor, and any such insurance obtained by any subcontractor or subcontractors shall be approved by the City of Peoria. In case any class of employees engaged in hazardous work at the site of the project is not protected under the Worker's Compensation statute, the Contractor shall provide, and shall cause each Subcontractor to provide adequate insurance coverage for the protection of his employees not otherwise protected, such as accident insurance, and any such insurance shall be approved by the City of Peoria.

PUBLIC LIABILITY AND PROPERTY DAMAGE INSURANCE

The Contractor shall take out and maintain during the life of the project such General Liability, Public Liability and Property Damage Insurance as shall protect him and any Subcontractor performing work covered by this project, from claims for damages for personal injury, including accidental death, as well as from claims for property damages, which may arise from operations under this project, whether such operations be by himself or by any Subcontractors or by anyone directly or indirectly employed by either of them and the amounts of such insurance shall be as follows:

Commercial General Liability Insurance that provides Property Damage and/or Bodily Injury in an amount not less than \$1,000,000 per occurrence and \$2,000,000 aggregate.

OWNER'S PROTECTIVE LIABILITY AND PROPERTY DAMAGE INSURANCE

The Contractor shall obtain Owner's Protective Liability and Property Damage Insurance in an amount not less than \$1,000,000 per occurrence and \$2,000,000 aggregate. If endorsements to the above public liability and property damage insurance policies cannot be made, then separate policies providing such protection must be furnished by the Contractor.

AUTOMOBILE INSURANCE

The Contractor shall take out and maintain during the life of the project such automobile insurance covering all owned and non-owned vehicles as shall protect him and any Subcontractor performing work covered by this project, from claims for damages in an amount not less than \$1,000,000 Combined Bodily Injury and Property Damage.

UMBRELLA COVERAGE

The Contractor shall take out and maintain during the life of the project such Umbrella or Excess Liability coverage as shall protect him and any Subcontractor performing work covered by this project, from claims for damages in an amount not less than \$2,000,000 per occurrence and \$5,000,000 annual aggregate.

ADDITIONAL INSURED ENDORSEMENT

All Liability insurance policies shall name the City of Peoria its officers, directors, employees, agents, representatives, subsidiaries, successors, and assigns, as additional insureds, shall be primary to any other insurance carried by the City of Peoria and shall provide coverage consistent with ISO CG 20 26, and shall maintain the required coverages, naming the City of Peoria as an additional insured, for a period of not less than three years from the date the City of Peoria and Contractor execute an Agreement to Final Quantities.

PROOF OF CARRIAGE OF INSURANCE

The Contractor and all Subcontractors shall furnish the City of Peoria with satisfactory proof of insurance coverage. This shall include an A.M. Best "A" rating before the project begins. If coverage is cancelled or the carrier's rating falls below A.M. Best "A" rated, the City of Peoria shall be notified in writing.

Certificates of insurance are required. The Certificate must state the following "The City of Peoria, its officers, directors, employees, agents, and representatives, are named as Additional Insured on a primary basis for liability arising out of the contractor's operations."

Upon request the Contractor must provide copies of the policies and endorsements, failure to provide the required certificates of insurance shall not operate to invalidate the insurance requirements under this Contract.

GUARANTEE PERIOD

The Contractor warrants all work performed under this contract is free from defects and was performed in accordance with the Contract Documents for a period of one (1) year from the date of agreement of final quantities, as agreed in writing, by the City Engineer after all parties have signed the document. In case of acceptance of a part of the work for use prior to the agreement to final quantities, the guarantee for the part so accepted shall be for a period of one (1) year from the date of such partial acceptance, in writing, by the City Engineer. Work performed due to this warranty requirement shall be guaranteed for a period of one (1) year. The Guarantee Period may be further amended in the Roadwork Special Provision.

PROSECUTION AND PROGRESS OF WORK

Special attention is called to Section 108 of the "Standard Specifications for Road and Bridge Construction," and specifically to Article 108.03, which states that the Contractor shall notify the Engineer at least twenty-four (24) hours in advance of either discontinuing or resuming operations.

If an Engineer or an Inspector for the City of Peoria Engineering Division is not on the job and notification as required has been given, the contractor in charge of the work shall immediately notify the Engineering Division that work has been resumed and request that the Project Engineer in charge of work for the City Engineering Division be notified.

Work performed without proper notification to the City Engineering Division as indicated herein may be rejected by the Engineer for the City of Peoria and no compensation will be made for said work. In addition, the contractor may be required to remove the item of construction at its own expense and replace the item of construction in accordance with the plans and specifications.

EXISTING UNDERGROUND FACILITIES

The City of Peoria assumes no responsibility for the presence, specific size or location of underground distribution systems of the several public utility corporations. No responsibility for the protection of said underground systems will be assumed by the City of Peoria unless such protection is incidental to the protection of the municipally-owned property of the City of Peoria. If such protection is found to be necessary to water mains, gas mains, steam mains, underground electrical distribution systems, underground telephone circuit systems or any other underground systems of non-municipal ownership, the cost of same, in whole or in part, is disclaimed by the City of Peoria.

COOPERATION WITH UTILITY COMPANIES

It is understood and agreed that the contractor has considered, in his bid, all the permanent and temporary utility appurtenances in their present or relocated positions and that no additional compensation will be allowed for any delays, inconvenience or damage sustained by him due to any interference from the said utility appurtenances or the operations of moving them.

All telephone, cableway, gas, water and wire lines, within the limits of the proposed construction owned by various utility companies, are to be moved by the owners of the particular utility involved at the owner's expense.

NOTIFICATION OF UTILITIES PRIOR TO CONSTRUCTION

All utility companies must be notified by the Contractor, in writing, at least one (1) week in advance prior to starting construction so that they will have adequate time to locate and mark their utility locations in the field and twenty-four (24) hours prior to commencing actual construction work. All utility companies must be notified so that they may have personnel on the job site to assist in locating their utility lines and avoid damage to their utilities. Specifically, AmerenCILCO, Comcast Communications, SBC, McLeod Communications and the Illinois-American Water Co., have requested that they be notified prior to the start of construction. A copy of the letter notifying the utility companies of the Contractor's intention to start work must be received by the City of Peoria Engineering Division before the Contractor will be permitted to start construction.

J.U.L.I.E. SYSTEM

The J.U.L.I.E. (Joint Utility Locating Information for Excavators) must be notified prior to starting construction, so that the respective utilities may have adequate time to locate and mark their underground facilities. Phone: 1-800-892-0123 or 811.

Since this is a Citywide program, J.U.L.I.E. will need to be notified before construction on each property.

CERTIFIED PAYROLL REQUIREMENTS

Contractors and subcontractors on public works projects must submit certified payroll records on a monthly basis to the public body in charge of the construction project, along with a statement affirming that such records are true and accurate, that the wages paid to each worker are not less than the required prevailing rate, and that the contractor is aware that filing records he or she knows to be false is a Class B Misdemeanor. The Certified Payroll Records must include, for every worker employed on the public works project, the name, address, telephone number, social security number, job classification, hourly wages paid in each pay period, number of hours worked each day, and starting and ending time of work each day. Certified payrolls are to be submitted on EPrismSoft, per the EEO guidelines outlined in Section VII of the Good Faith Efforts Requirements, herein.

PREVAILING WAGE PROVISION

This contract is for the performance of “public works” as that term is defined by 820 ILCS 130/2. Not less than the prevailing rate of wages as found by the Illinois Department of Labor or determined by a Court on review shall be paid to all laborers, workers and mechanics performing work under this contract. *These prevailing rates of wages have not been revised by the State’s Department of Labor since July 2015.*

It shall be the contractor’s responsibility to monitor the prevailing wages and adjust his payroll accordingly as soon as any rates are revised by the Department of Labor.

Updated rates may be found here:

<http://www.illinois.gov/idol/Laws-Rules/CONMED/Pages/prevailing-wage-rates.aspx>

Peoria County Prevailing Wage for July 2015

(See explanation of column headings at bottom of wages)

Trade Name	RG	TYP	C	Base	FRMAN	M-F>8	OSA	OSH	H/W	Pensn	Vac	Trng
ASBESTOS ABT-GEN	BLD			26.700	28.200	1.5	1.5	2.0	7.700	16.21	0.000	0.800
ASBESTOS ABT-GEN	HWY			29.910	31.410	1.5	1.5	2.0	7.700	17.47	0.000	0.800
ASBESTOS ABT-MEC	BLD			32.510	35.010	1.5	1.5	2.0	11.47	10.96	0.000	0.720
BOILERMAKER	BLD			38.000	41.000	2.0	2.0	2.0	7.070	15.99	0.000	0.400
BRICK MASON	BLD			32.380	33.880	1.5	1.5	2.0	8.600	9.870	0.000	0.590
CARPENTER	BLD			30.880	33.130	1.5	1.5	2.0	8.000	15.71	0.000	0.520
CARPENTER	HWY			32.700	34.950	1.5	1.5	2.0	8.000	15.81	0.000	0.520
CEMENT MASON	BLD			28.050	29.800	1.5	1.5	2.0	7.500	15.65	0.000	0.500
CEMENT MASON	HWY			29.280	30.780	1.5	1.5	2.0	7.500	16.02	0.000	0.500
CERAMIC TILE FNSHER	BLD			29.890	0.000	1.5	1.5	2.0	8.600	10.05	0.000	0.580
ELECTRIC PWR EQMT OP	ALL			38.300	45.290	1.5	1.5	2.0	6.150	10.73	0.000	0.380
ELECTRIC PWR GRNDMAN	ALL			26.280	45.290	1.5	1.5	2.0	5.790	7.360	0.000	0.260
ELECTRIC PWR LINEMAN	ALL			42.540	45.290	1.5	1.5	2.0	6.280	11.92	0.000	0.430
ELECTRIC PWR TRK DRV	ALL			27.560	45.290	1.5	1.5	2.0	5.830	7.720	0.000	0.280
ELECTRICIAN	ALL			34.820	37.320	1.5	1.5	2.0	6.500	11.68	0.000	0.800
ELECTRICIAN	BLD			34.820	37.320	1.5	1.5	2.0	6.100	11.43	0.000	0.400
ELECTRONIC SYS TECH	BLD			28.250	30.250	1.5	1.5	2.0	6.350	10.54	0.000	0.400
ELEVATOR CONSTRUCTOR	BLD			41.690	46.900	2.0	2.0	2.0	13.57	14.21	3.340	0.600
GLAZIER	BLD			31.870	33.870	1.5	1.5	1.5	10.25	7.700	0.000	1.250
HT/FROST INSULATOR	BLD			43.350	45.850	1.5	1.5	2.0	11.47	12.36	0.000	0.720
IRON WORKER	BLD			32.190	34.090	0.0	0.0	0.0	9.490	13.91	0.000	0.000
IRON WORKER	HWY			35.980	37.980	0.0	0.0	0.0	9.490	13.91	0.000	0.000
LABORER	BLD			25.700	27.200	1.5	1.5	2.0	7.700	16.21	0.000	0.800
LABORER	HWY			29.160	30.660	1.5	1.5	2.0	7.700	17.47	0.000	0.800
LABORER, SKILLED	BLD			26.100	27.600	1.5	1.5	2.0	7.700	16.21	0.000	0.800
LABORER, SKILLED	HWY			29.460	30.960	1.5	1.5	2.0	7.700	17.47	0.000	0.800
LATHER	BLD			30.880	33.130	1.5	1.5	2.0	8.000	15.71	0.000	0.520
MACHINERY MOVER	HWY			35.980	37.980	0.0	0.0	0.0	9.490	13.91	0.000	0.000
MACHINIST	BLD			45.350	47.850	1.5	1.5	2.0	7.260	8.950	1.850	0.000
MARBLE FINISHERS	BLD			29.890	0.000	1.5	1.5	2.0	8.600	10.05	0.000	0.580
MARBLE MASON	BLD			31.650	32.900	1.5	1.5	2.0	8.600	10.05	0.000	0.580
MILLWRIGHT	BLD			31.060	33.310	1.5	1.5	2.0	8.000	15.87	0.000	0.520
MILLWRIGHT	HWY			33.060	35.310	1.5	1.5	2.0	8.000	15.95	0.000	0.520
OPERATING ENGINEER	BLD	1		37.050	40.050	1.5	1.5	2.0	7.000	17.48	0.000	3.000
OPERATING ENGINEER	BLD	2		34.450	40.050	1.5	1.5	2.0	7.000	17.48	0.000	3.000
OPERATING ENGINEER	BLD	3		30.160	40.050	1.5	1.5	2.0	7.000	17.48	0.000	3.000
OPERATING ENGINEER	HWY	1		38.150	41.150	1.5	1.5	2.0	7.250	18.23	0.000	3.000
OPERATING ENGINEER	HWY	2		35.460	41.150	1.5	1.5	2.0	7.250	18.23	0.000	3.000
OPERATING ENGINEER	HWY	3		31.030	41.150	1.5	1.5	2.0	7.250	18.23	0.000	3.000
PAINTER	ALL			33.650	35.650	1.5	1.5	1.5	10.30	8.200	0.000	1.350
PAINTER SIGNS	BLD			33.920	38.090	1.5	1.5	1.5	2.600	2.710	0.000	0.000
PILEDRIIVER	BLD			31.880	34.130	1.5	1.5	2.0	8.000	15.71	0.000	0.520
PILEDRIIVER	HWY			33.700	35.950	1.5	1.5	2.0	8.000	15.81	0.000	0.520
PIPEFITTER	BLD			37.400	41.510	1.5	1.5	2.0	7.000	11.63	0.000	1.060
PLASTERER	BLD			28.140	29.770	1.5	1.5	2.0	7.500	15.00	0.000	0.870
PLUMBER	BLD			34.520	37.630	1.5	1.5	2.0	7.000	13.86	0.000	0.950
ROOFER	BLD			30.580	32.110	1.5	1.5	2.0	8.450	7.220	0.000	0.250
SHEETMETAL WORKER	BLD			32.430	34.050	1.5	1.5	2.0	9.120	15.55	0.000	0.780
SIGN HANGER	HWY			35.980	37.980	0.0	0.0	0.0	9.490	13.91	0.000	0.000
SPRINKLER FITTER	BLD			37.120	39.870	1.5	1.5	2.0	8.420	8.500	0.000	0.350
STEEL ERECTOR	HWY			35.980	37.980	0.0	0.0	0.0	9.490	13.91	0.000	0.000
STONE MASON	BLD			32.380	33.880	1.5	1.5	2.0	8.600	9.870	0.000	0.590
SURVEY WORKER	-->NOT IN EFFECT				ALL	28.900	30.400	1.5	1.5	2.0	7.700	
TERRAZZO FINISHER	BLD			29.890	0.000	1.5	1.5	2.0	8.600	10.05	0.000	0.580

TERRAZZO MASON	BLD	31.650	32.900	1.5	1.5	2.0	8.600	10.05	0.000	0.58
TILE MASON	BLD	31.650	32.900	1.5	1.5	2.0	8.600	10.05	0.000	0.58
TRUCK DRIVER	ALL 1	33.000	36.550	1.5	1.5	2.0	11.10	5.230	0.000	0.250
TRUCK DRIVER	ALL 2	33.480	36.550	1.5	1.5	2.0	11.10	5.230	0.000	0.250
TRUCK DRIVER	ALL 3	33.700	36.550	1.5	1.5	2.0	11.10	5.230	0.000	0.250
TRUCK DRIVER	ALL 4	34.010	36.550	1.5	1.5	2.0	11.10	5.230	0.000	0.250
TRUCK DRIVER	ALL 5	34.900	36.550	1.5	1.5	2.0	11.10	5.230	0.000	0.250
TRUCK DRIVER	O&C 1	27.280	30.220	1.5	1.5	2.0	11.40	5.440	0.000	0.250
TRUCK DRIVER	O&C 2	27.680	30.220	1.5	1.5	2.0	11.40	5.440	0.000	0.250
TRUCK DRIVER	O&C 3	27.860	30.220	1.5	1.5	2.0	11.40	5.440	0.000	0.250
TRUCK DRIVER	O&C 4	28.110	30.220	1.5	1.5	2.0	11.40	5.440	0.000	0.250
TRUCK DRIVER	O&C 5	28.850	30.220	1.5	1.5	2.0	11.40	5.440	0.000	0.250

TUCKPOINTER BLD 32.380 33.880 1.5 1.5 2.0 8.600 9.870 0.000 0.590

Legend: RG (Region)

TYP (Trade Type - All, Highway, Building, Floating, Oil & Chip, Rivers)

C (Class)

Base (Base Wage Rate)

FRMAN (Foreman Rate)

M-F>8 (OT required for any hour greater than 8 worked each day, Mon through Fri.)

OSA (Overtime (OT) is required for every hour worked on Saturday)

OSH (Overtime is required for every hour worked on Sunday and Holidays)

H/W (Health & Welfare Insurance)

Pensn (Pension)

Vac (Vacation)

Trng (Training)

Explanations

PEORIA COUNTY

The following list is considered as those days for which holiday rates of wages for work performed apply: New Years Day, Memorial Day, Fourth of July, Labor Day, Thanksgiving Day, Christmas Day and Veterans Day in some classifications/counties. Generally, any of these holidays which fall on a Sunday is celebrated on the following Monday. This then makes work performed on that Monday payable at the appropriate overtime rate for holiday pay. Common practice in a given local may alter certain days of celebration. If in doubt, please check with IDOL.

Oil and chip resealing (O&C) means the application of road oils and liquid asphalt to coat an existing road surface, followed by application of aggregate chips or gravel to coated surface, and subsequent rolling of material to seal the surface.

EXPLANATION OF CLASSES

ASBESTOS - GENERAL - removal of asbestos material/mold and hazardous materials from any place in a building, including mechanical systems where those mechanical systems are to be removed. This includes the removal of asbestos materials/mold and hazardous materials from ductwork or pipes in a building when the building is to be demolished at the time or at some close future date.

ASBESTOS - MECHANICAL - removal of asbestos material from mechanical systems, such as pipes, ducts, and boilers, where the mechanical systems are to remain.

CERAMIC TILE FINISHER, MARBLE FINISHER, TERRAZZO FINISHER

Assisting, helping or supporting the tile, marble and terrazzo mechanic by performing their historic and traditional work assignments required to complete the proper installation of the work covered by said crafts. The term "Ceramic" is used for naming the classification

only and is in no way a limitation of the product handled. Ceramic takes into consideration most hard tiles.

ELECTRONIC SYSTEMS TECHNICIAN

Installation, service and maintenance of low-voltage systems which utilizes the transmission and/or transference of voice, sound, vision, or digital for commercial, education, security and entertainment purposes for the following: TV monitoring and surveillance, background/foreground music, intercom and telephone interconnect, field programming, inventory control systems, microwave transmission, multi-media, multiplex, radio page, school, intercom and sound burglar alarms and low voltage master clock systems.

Excluded from this classification are energy management systems, life safety systems, supervisory controls and data acquisition systems not intrinsic with the above listed systems, fire alarm systems, nurse call systems and raceways exceeding fifteen feet in length.

LABORER, SKILLED - BUILDING

The skilled laborer building (BLD) classification shall encompass the following types of work, irrespective of the site of the work: cutting & acetylene torch, gunnite nozzle men, gunnite pump men & pots, kettlemen & carriers of men handling hot stuff, sandblaster nozzle men, sandblasting pump men & pots, setting up and using concrete burning bars, wood block setters, underpinning & shoring of existing buildings, and the unloading and handling of all material coated with creosote.

LABORER, SKILLED - HIGHWAY

The skilled laborer heavy & highway (HWY) classification shall encompass the following types of work, irrespective of the site of the work: jackhammer & drill operator, gunnite pump & pot man, puddlers, vibrator men, wire fabric placer, sandblast pump & pot man, strike off concrete, unloading, handling & carrying of all creosoted piles, ties or timber, concrete burning bars, power wheelbarrows or buggies, asphalt raker, brickset-ters, cutting torchman (electric & acetylene), men setting lines to level forms, form setters, gunnite nozzle man & sandblasting nozzle man, power man, and rip-rapping by hand.

SURVEY WORKER - Operated survey equipment including data collectors, G.P.S. and robotic instruments, as well as conventional levels and transits.

TRUCK DRIVER - BUILDING, HEAVY AND HIGHWAY CONSTRUCTION

Class 1. Drivers on 2 axle trucks hauling less than 9 ton. Air compressor and welding machines and brooms, including those pulled by separate units, truck driver helpers, warehouse employees, mechanic helpers, greasers and tiremen, pickup trucks when hauling materials, tools, or workers to and from and on-the-job site, and fork lifts up to 6,000 lb. capacity.

Class 2. Two or three axle trucks hauling more than 9 ton but hauling less than 16 ton. A-frame winch trucks, hydrolift trucks, vactor trucks or similar equipment when used for transportation purposes. Fork lifts over 6,000 lb. capacity, winch trucks, four axle combination units, and ticket writers.

Class 3. Two, three or four axle trucks hauling 16 ton or more. Drivers on water pulls, articulated dump trucks, mechanics and working forepersons, and dispatchers. Five axle or more combination units.

Class 4. Low Boy and Oil Distributors.

Class 5. Drivers who require special protective clothing while employed on hazardous waste work.

TRUCK DRIVER - OIL AND CHIP RESEALING ONLY.

This shall encompass laborers, workers and mechanics who drive contractor or subcontractor owned, leased, or hired pickup, dump, service, or oil distributor trucks. The work includes transporting materials and equipment (including but not limited to, oils, aggregate supplies, parts, machinery and tools) to or from the job site; distributing oil or liquid asphalt and aggregate; stock piling material when in connection with the actual oil and chip contract. The Truck Driver (Oil & Chip Resealing) wage classification does not include supplier delivered materials.

OPERATING ENGINEERS - BUILDING

Class 1. Cranes; Overhead Cranes; Gradall; All Cherry Pickers; Mechanics; Central Concrete Mixing Plant Operator; Road Pavers (27E - Dual Drum - Tri Batchers); Blacktop Plant Operators and Plant Engineers; 3 Drum Hoist; Derricks; Hydro Cranes; Shovels; Skimmer Scoops; Koehring Scooper; Drag Lines; Backhoe; Derrick Boats; Pile Drivers and Skid Rigs; Clamshells; Locomotive Cranes; Dredge (all types) Motor Patrol; Power Blades - Dumore - Elevating and similar types; Tower Cranes (Crawler-Mobile) and Stationary; Crane-type Backfiller; Drott Yumbo and similar types considered as Cranes; Caisson Rigs; Dozer; Tournadozer; Work Boats; Ross Carrier; Helicopter; Tournapulls - all and similar types; Scoops (all sizes); Pushcats; Endloaders (all types); Asphalt Surfacing Machine; Slip Form Paver; Rock Crusher; Heavy Equipment Greaser; CMI, CMI Belt Placer, Auto Grade & 3 Track and similar types; Side Booms; Multiple Unit Earth Movers; Creter Crane; Trench Machine; Pump-crete-Belt Crete-Squeeze Cretes-Screw-type Pumps and Gypsum; Bulker & Pump - Operator will clean; Formless Finishing Machine; Flaherty Spreader or similar types; Screed Man on Laydown Machine; Wheel Tractors (industrial or Farm-type w/Dozer-Hoe-Endloader or other attachments); F.W.D. & Similar Types; Vermeer Concrete Saw.

Class 2. Dinkeys; Power Launches; PH One-pass Soil Cement Machine (and similar types); Pugmill with Pump; Backfillers; Euclid Loader; Forklifts; Jeeps w/Ditching Machine or other attachments; Tuneluger; Automatic Cement and Gravel Batching Plants; Mobile Drills (Soil Testing) and similar types; Guries and Similar Types; (1) and (2) Drum Hoists (Buck Hoist and Similar Types); Chicago Boom; Boring Machine & Pipe Jacking Machine; Hydro Boom; Dewatering System; Straw Blower; Hydro Seeder; Assistant Heavy Equipment Greaser on Spread; Tractors (Track type) without Power Unit pulling Rollers; Rollers on Asphalt -- Brick Macadem; Concrete Breakers; Concrete Spreaders; Mule Pulling Rollers; Center Stripper; Cement Finishing Machines & CMI Texture & Reel Curing Machines; Cement Finishing Machine; Barber Green or similar loaders; Vibro Tamper (All similar types) Self-propelled; Winch or Boom Truck; Mechanical Bull Floats; Mixers over 3 Bag to 27E; Tractor pulling Power Blade or Elevating Grader; Porter Rex Rail; Clary Screed; Truck Type Hoptoe Oilers; Fireman; Spray Machine on Paving; Curb Machines; Truck Crane Oilers; Oil Distributor; Truck-Mounted Saws.

Class 3. Air Compressor; Power Subgrader; Straight Tractor; Trac Air without attachments; Herman Nelson Heater, Dravo, Warner, Silent Glo, and similar types; Roller: Five (5) Ton and under on Earth or Gravel; Form Grader; Crawler Crane & SkidRig Oilers; Freight Elevators - permanently installed; Pump; Light Plant; Generator;

Conveyor (1) or (2) - Operator will clean; Welding Machine; Mixer (3) Bag and Under (Standard Capacity with skip); Bulk Cement Plant; Oiler on Central Concrete Mixing Plant.

OPERATING ENGINEERS - HEAVY AND HIGHWAY CONSTRUCTION

CLASS 1. Cranes; Hydro Cranes; Shovels; Crane Type Backfiller; Tower, Mobile, Crawler, & Stationary Cranes; Derricks; Hoists (3 Drum); Draglines; Drott Yumbo & Similar Types considered as Cranes; 360 Degree Swing Excavator (Shears, Grapples, Movacs, etc.); Back Hoe; Derrick Boats; Pile Driver and Skid Rigs; Clam Shell; Locomotive - Cranes; Road Pavers - Single Drum - Dual Drum - Tri Batcher; Motor Patrols & Power Blades - Dumore - Elevating & Similar Types; Mechanics; Central Concrete Mixing Plant Operator; Asphalt Batch Plant Operators and Plant Engineers; Gradall; Caisson Rigs; Skimmer Scoop - Koering Scooper; Dredges (all types); Hoptoe; All Cherry Pickers; Work Boat; Ross Carrier; Helicopter; Dozer; Tournadozer; Tournapulls - all and similar types; Operation of Concrete and all Recycle Machines; Multiple Unit Earth Movers; Scoops (all sizes); Pushcats; Endloaders (all types); Asphalt Surfacing Machine; Slip Form Paver; Rock Crusher; Operation of Material Crusher, Screening Plants, and Tunnel Boring Machine; Heavy Equipment Greaser (top greaser on spread); CMI, Auto Grade, CMI Belt Placer & 3 Track and Similar Types; Side Booms; Asphalt Heater & Planer Combination (used to plane streets); Wheel Tractors (with Dozer, Hoe or Endloader Attachments); CAT Earthwork Compactors and Similar Types; Blaw Knox Spreader and Similar Types; Trench Machines; Pump Crete - Belt Crete - Squeeze Crete - Screw Type Pumps and Gypsum (operator will clean); Creter Crane; Operation of Concrete Pump Truck; Formless Finishing Machines; Flaherty Spreader or Similar Types; Screed Man on Laydown Machine; Vermeer Concrete Saw; Operation of Laser Screed; Span Saw; Dredge Leverman; Dredge Engineer; Lull or Similar Type; Hydro-Boom Truck; Operation of Guard Rail Machine; and Starting Engineer on Pipeline or Construction (11 or more pieces) including: Air Compressor (Trailer Mounted), All Forced Air Heaters (regardless of Size), Water Pumps (Greater than 4-1/2" or Total Discharge Over 4-1/2"), Light Plants, Generators (Trailer Mounted - Excluding Decontamination Trailer), Welding Machines (Any Size or Mode of Power), Conveyor, Mixer (any size), Stud Welder, Power Pac, etc, and Ground Heater (Trailer Mounted).

CLASS 2. Bulker & Pump; Power Launches; Boring Machine & Pipe Jacking Machine; Dinkeys; Operation of Carts, Powered Haul Unit for a Boring Machine; P & H One Pass Soil Cement Machines and Similar Types; Wheel Tractors (Industry or Farm Type - Other); Back Fillers; Euclid Loader; Fork Lifts; Jeep w/Ditching Machine or Other Attachments; Tunneluger; Automatic Cement & Gravel Batching Plants; Mobile Drills - Soil Testing and Similar Types; Pugmill with Pump; All (1) and (2) Drum Hoists; Dewatering System; Straw Blower; Hydro-Seeder; Bump Grinders (self-propelled); Assistant Heavy Equipment Greaser; Apsco Spreader; Tractors (Track-Type) without Power Units Pulling Rollers; Rollers on Asphalt - Brick or Macadam; Concrete Breakers; Concrete Spreaders; Cement Strippers; Cement Finishing Machines & CMI Texture & Reel Curing Machines; Vibro-Tampers (All Similar Types Self-Propelled); Mechanical Bull Floats; Self-Propelled Concrete Saws; Truck Mounted Power Saws; Operation of Curb Cutters; Mixers - Over Three (3) Bags; Winch and Boom Trucks; Tractor Pulling Power Blade or Elevating Grader; Porter Rex Rail; Clary Screed; Mule Pulling Rollers; Pugmill without Pump; Barber Greene or Similar Loaders; Track Type Tractor w/Power Unit attached (minimum); Fireman; Spray Machine on Paving; Curb Machines; Paved Ditch Machine; Power Broom; Self-Propelled Sweepers; Self-Propelled Conveyors; Power Subgrader; Oil Distributor; Straight Tractor; Truck Crane Oiler; Truck Type Oilers; Directional Boring Machine; Horizontal Directional Drill; Articulating End Dump

Vehicles; Starting Engineer on Pipeline or Construction (6 -10 pieces) including: Air Compressor (Trailer Mounted), All Forced Air Heaters (regardless of Size), Water Pumps (Greater than 4-1/2" or Total Discharge Over 4-1/2"), Light Plants, Generators (Trailer Mounted - Excluding Decontamination Trailer), Welding Machines (Any Size or Mode of Power), Conveyor, Mixer (any size), Stud Welder, Power Pac, etc., and Ground Heater (Trailer Mounted).

CLASS 3. Straight Framed Truck Mounted Vac Unit (separately powered); Trac Air Machine (without attachments); Rollers - Five Ton and Under on Earth and Gravel; Form Graders; Bulk Cement Plant; Oilers; and Starting Engineer on Pipeline or Construction (3 - 5 pieces) including: Air Compressor (Trailer Mounted), All Forced Air Heaters (regardless of Size), Water Pumps (Greater than 4-1/2" or Total Discharge Over 4-1/2"), Light Plants, Generators (Trailer Mounted - Excluding Decontamination Trailer), Welding Machines (Any Size or Mode of Power), Conveyor, Mixer (any size), Stud Welder, Power Pac, etc., and Ground Heater (Trailer Mounted).

Other Classifications of Work:

For definitions of classifications not otherwise set out, the Department generally has on file such definitions which are available. If a task to be performed is not subject to one of the classifications of pay set out, the Department will upon being contacted state which neighboring county has such a classification and provide such rate, such rate being deemed to exist by reference in this document. If no neighboring county rate applies to the task, the Department shall undertake a special determination, such special determination being then deemed to have existed under this determination. If a project requires these, or any classification not listed, please contact IDOL at 217-782-1710 for wage rates or clarifications.

LANDSCAPING

Landscaping work falls under the existing classifications for laborer, operating engineer and truck driver. The work performed by landscape plantsman and landscape laborer is covered by the existing classification of laborer. The work performed by landscape operators (regardless of equipment used or its size) is covered by the classifications of operating engineer. The work performed by landscape truck drivers (regardless of size of truck driven) is covered by the classifications of truck driver.

SUBSTANCE ABUSE PREVENTION PROGRAM

Before the Contractor and any Subcontractor commences work, the Contractor and any Subcontractor shall have in place a written Substance Abuse Prevention Program for the prevention of substance abuse among its employees which meets or exceeds the requirements in P.A. 95-0635 or shall have a collective bargaining agreement in effect dealing with the subject matter of P.A. 95-0635.

The Contractor and any Subcontractor shall file with a public body: a copy of the substance abuse prevention program along with a cover letter certifying that their program meets the requirements of the Act, or a letter certifying that the Contractor or a Subcontractor has a collective bargaining agreement in effect dealing with the subject matter of the Act.

PROTECTION OF THE PUBLIC

In general, protection of the public shall be in accordance with Chapter 26, Article V of the Code of the City of Peoria, Illinois entitled "Excavation Generally," except that Sections 26-139, 26-140, 26-141 and 26-142 shall not apply.

Barricades, warning signs, and other devices shall be maintained as provided for by the City Code herein referred. The cost of any signs, barricades, or warning devices required to adequately accomplish partial or complete closure of streets shall be incidental to the item of work for which the traffic control is needed, and no additional compensation will be allowed.

ITEMS DESIGNATED FOR REMOVAL AND EXCAVATION

All removal items and excavated material remain the property of the Contractor unless otherwise indicated in the contract documents. The Contractor shall dispose of the removed items and/or excavated material outside the limits of the improvement as the Contractor may provide. Excavated material to remain on the job site shall be placed as directed by the Engineer.

CITY SIGNS

The contractor, at his own expense, shall be required, as directed by the Engineer, to relocate or remove and reinstall all street, traffic, parking, etc. signs belonging to the City within the limits of the improvement. All signs which interfere with construction operations shall be removed, stored in a place away from work, and replaced by the contractor after the improvement has been completed if they are not required for traffic control. Signs which are required for traffic control shall be reinstalled at a temporary location acceptable to the Engineer, in a workmanlike manner, visible to traffic, and maintained straight and neat for the duration of the temporary setting. Signs shall not be moved until progress of the work demands the relocation. The cost of this item shall be included in the contract unit price bid for the item of work which necessitated the removal.

BRICK REPAIRS

There may be brick sidewalk repairs conducted under this contract. There may also be brick sidewalks replaced with concrete sidewalks. Where new concrete sidewalk will abut to existing brick sidewalk the contractor will be responsible for making any necessary adjustments to the brick sidewalk to match the new concrete sidewalk. The City will provide any new brick required for the necessary adjustments. This work shall be considered incidental to the affected items of work and no additional compensation will be allowed.

TRAFFIC CONTROL & PROTECTION

Traffic control shall be in accordance with the applicable sections of the "Standard Specifications for Road and Bridge Construction," the applicable guidelines contained in the "Manual on Uniform Traffic Control Devices for Streets and Highways," these special provisions, and any special details and Highway standards contained herein and in the plans.

Special attention is called to Articles 107.09 and 107.14 of the "Standard Specifications for Road and Bridge Construction," applicable "Recurring Supplemental Specifications and Special Provisions" and the following Highway Standards relating to traffic control:

(701301-04; 701501-06; 701502-06; 701601-09; 701602-07; 701606-09; 701701-09; 701801-05; and 701901-03)

When construction operations require the closure of one lane, except turn lanes, the closure of said lane shall require the use of the specified arrow board per Standard 701901-03. The work shall be performed as directed by the Engineer.

Traffic movement should be inhibited as little as practical. Motorists should be guided in a clear and positive manner while approaching and traversing construction work areas. To ensure acceptable levels of operation, routine inspection of traffic control elements should be performed. The contractor will be required to inspect and initiate any needed maintenance to the traffic control devices on this contract. All traffic control devices shall be removed immediately when no longer needed. Construction equipment, materials and debris should be stored in such a manner as to not be vulnerable to vehicle impact, as directed by the Engineer.

The Contractor is expected to maintain a minimum of one lane open to traffic at all times for traffic. The roadway may be closed for short periods in order to offload materials. However, this operation must take place with proper traffic control signage and/or flagmen as noted in the traffic control standards contained herein. Roadway closures, regardless of duration must be coordinated with City of Peoria Police and Fire Departments. It is absolutely necessary that one lane of roadway can be used by fire, police, and other emergency vehicles at all times under all weather conditions.

The contractor shall, at all times, maintain a means for sidewalk traffic to detour the job. He shall also provide a minimum of interference to vehicular traffic and shall maintain barricades and warning signs as provided by the "Standard Specifications for Road and Bridge Construction."

The Contractor will be responsible for scheduling his operations to provide access to all businesses located along the improvement that have current access to the street. No less than one entrance to

each commercial parking lot or building shall remain open at all times during construction.

The Contractor will be responsible with scheduling garbage pick up in the neighborhood along with notifying in writing no less than 3 calendar days before removing any part of existing alleys or driveways.

Non-Conformance: If the Contractor fails to comply with the above conditions, the Engineer may suspend the Contractor's work until the Contractor is in compliance with the above conditions.

TRAFFIC CONTROL AND PROTECTION will not be paid for separately, but shall be considered incidental to the affected items of work to be done.

DAMAGE TO EXISTING TREES

All necessary precautions shall be taken to prevent damage to existing trees. Roots of two inch (2") diameter or more shall not be severed. Precautions shall be taken to prevent damage to the bark of existing trees by machinery or other means. Any damage shall be corrected as directed by the Engineer at the expense of the Contractor.

VAULTS

After the wall of the structure has been blocked (at property owner expense) and the concrete floor broke; the vault shall either be filled with flowable fill within 2" of grade and leveled with CA-6 or filled completely with granular material as directed by engineer within 10" of grade and topped with 6" of CA-6. All costs will be paid for per Article 109.04.

SAWCUTTING

Sawcutting shall be required at all locations where new concrete meets existing concrete unless otherwise approved by the Engineer. This shall be considered incidental to the item of construction involved and no additional compensation will be allowed. Sawcuts shall be parallel/perpendicular with existing curb, sidewalks and or drives

CONTACT PERSON

The City's designated Engineer will be responsible for this contract. Any questions you may have in reference to any portion of the bidding process can be directed to the Public Works Department, 494-8800. The City's Project Manager is Stephen Letsky, PE, Civil Engineer II.

EQUAL OPPORTUNITY REQUIREMENTS

EEO CONTRACT COMPLIANCE CLAUSE

It is hereby declared to be the public policy of the City of Peoria, that it will not execute a contract for goods and/or services with any individual, business enterprise, supplier/vendor; maintain a financial relationship with any financial institution; or use the services of any labor organization or member thereof found to be in violation of the provisions of the Municipal Code for the City of Peoria, Chapter 17, Article III, Division 4, Section 17-118.

This clause covers contractors, vendors, suppliers, borrowers and/or recipients of city resources, purchasers and/or developers of city owned property, and any other individuals or entities providing goods and/or services to the City of Peoria; and are hereinafter referred to as "Contractor."

If any Contractor conducting business with the City of Peoria fails to comply with the fair employment and affirmative action provisions of Chapter 17, Article III, Division 4 of the municipal code (hereinafter Chapter 17), the city, at its option, may do any or all of the following:

- (1) Cancel, terminate, or suspend the contract in whole or in part;
- (2) Declare the contractor ineligible for further contracts for one calendar year;
- (3) The Fair Employment and Housing Commission (hereinafter FEHC), in accordance with its rules and regulations, shall have the power to impose a penalty upon any Contractor failing to comply with Chapter 17 in an amount not less than \$50.00; nor more than as provided in Chapter 1, Section 1-5 of the municipal code, for each day that the Contractor fails to comply, upon a specific finding of such violation. The FEHC may order a Contractor found guilty of failure to comply with the provisions of Chapter 17 to pay all or a portion of the legal costs incurred by the city as a result of prosecution of such violations. Penalties assessed under the this clause may be recovered from the Contractor by setoff against unpaid portion of the contract price; and
- (4) Such other sanctions as may be imposed by the FEHC pursuant to the provisions of Chapter 17 and other applicable ordinance provisions of the municipal code.

During the performance of this contract, the Contractor agrees:

- (A) That it will not discriminate against any employee or applicant for employment because of race, color, religion, sex, sexual harassment, ancestry, national origin, place of birth, age, or a physical and/or mental disability which would not interfere with the efficient performance of the job in question. The contractor/vendor will take affirmative action to comply with the provisions of Peoria City Code, Chapter 17 and will require any subcontractor to submit to the City of Peoria a written commitment to comply with this division. The Contractor will distribute copies of this commitment to all persons who participate in recruitment, screening, referral, and selection of job applicants, prospective job applicants, members, or prospective contractors.

The Contractor agrees that the provisions of Chapter 17, of the Municipal Code of the City of Peoria is hereby incorporated by reference, as if set out verbatim
- (B) That it will examine each one of its workforce job classifications to determine if minorities and/or females are underutilized; and it will take appropriate affirmative action steps to rectify such identified underutilization.
- (C) That if it hires additional employees in order to perform this contract or any portion thereof, it will determine the availability of minority and females in the area(s) from which it may reasonably recruit; and every good faith effort will be made in its selection process to minimize or eliminate identified areas of minority and/or female underutilization for each job classification for which there are employment opportunities.

EEO Contract Compliance Clause

Page 2

- (D) That during the performance of this contract, the Contractor will maintain its eligibility status to conduct business with the City of Peoria under the provisions of the EEO certification registration program.
- (E) That in all solicitations or advertisements for employees placed by it or on its behalf, it will state that all applicants will be afforded equal opportunity without discrimination because of race, color, sex, religion, national origin, age, or physical and/or mental disability.
- (F) That it will send to each labor organization or representative of workers with which it has or is bound by a collective bargaining agreement or understanding, a notice advising such labor organization or representative of the Contractor's obligations under Chapter 17. If any such labor organization or representative fails or refuses to cooperate with the Contractor in its efforts to comply with Chapter 17, the Contractor will promptly so notify the Equal Opportunity Office (hereinafter EEO) and/or the FEHC for the City of Peoria.
- (G) That it will submit reports as required and furnish all relevant information as may from time to time be requested the EEO and/or the FEHC.
- (H) That it will permit access to all relevant books, records, accounts and work sites by EEO staff members for purposes of investigation to ascertain compliance with Chapter 17.
- (I) That it will include verbatim or by reference the provisions of Section 17-120 of Chapter 17 so that such provisions will be binding in the same manner as with other provisions of this contract. The Contractor will be liable for compliance with applicable provisions of this clause by all its subcontractors; and further, it will promptly notify the EEO and/or FEHC in the event any subcontractor fails or refuses to comply therewith. In addition, no Contractor will utilize any subcontractor declared by the EEO and/or FEHC to be non-responsive and therefore, ineligible for contracts or subcontracts with the City of Peoria.
- (J) That during the performance of this contract, the Contractor agrees: that it will have written sexual harassment policies that shall include, at a minimum, the following information: (i) the illegality of sexual harassment; (ii) the definition of sexual harassment under state law; (iii) a description of sexual harassment utilizing examples; (iv) the contractor's internal complaint process including penalties; (v) the legal recourse, investigative and complaint process available through the Illinois Department of Human Rights and the Human Rights Commission; (vi) directions on how to contact the Department of Human Rights and the Commission; and (vii) protection against retaliation as provided by Section 6-101 of this Act (Public Act 87-1257). A copy of the policies shall be provided to the Illinois Department of Human Rights or the City of Peoria upon request.
- (K) That during the performance of this contract, the Contractor agrees that they do not and will not maintain or provide for their employees, any segregated facilities at any of their establishments, or permit employees to perform their services at any location under their control where segregated facilities are maintained.

As used in this document, the term segregated facilities means any waiting rooms, work areas, rest rooms and wash rooms, and other storage or dressing areas, parking lots, drinking fountains, recreation or entertainment areas, transportation, housing facilities provided for employees which are segregated by explicit directive or are in fact segregated on the basis of race, religion, color, national origin, because of habit, local custom, or otherwise.

(Revised 01/04)



MINORITY AND WOMEN'S BUSINESS ENTERPRISE (M/WBE) PARTICIPATION

REQUIREMENTS FOR GOOD-FAITH EFFORTS (Projects exceeding \$50,000)

Description of Program

- A. It is the policy of the City of Peoria to encourage participation of M/WBE's on all city-funded construction projects. In complying with this clause bidders are required, when subcontracting opportunities are available, to make a good-faith effort to meet the goals established for M/WBE participation. The participation goals are cited in Section VI on the Subcontractor Utilization Statement.
- B. Failure to submit the documentation requested in Sections II and III of this document may cause (1) the bid to be rejected and determined non-responsive; (2) subject the bidders to the sanctions described in Section VIII.

Pre-Bid Efforts when Awarding Subcontracts

- A. Bidders are required to contact and solicit, in writing, bids from M/WBEs for available subcontracting. In seeking solicitations, bidders are to identify the portion(s) of work to be subcontracted and offer to break down any portion(s) of work into economically feasible units in order to facilitate M/WBE participation. Bidders also are to provide the name of a specific contact person in their notice to the M/WBEs. Contact shall be made prior to bid opening. The name of each company contacted, the date and method must be submitted with bid documents.

The low bidder shall provide to the City of Peoria, upon request, copies of faxes, letters, and e-mails sent to M/WBEs

- B. Bidders who are a MBE or WBE are not exempt from soliciting bids for available subcontracting. The bidder is required to contact, in writing, firms that will help the bidder meet the participation goal for the targeted group opposite to which the bidder belongs. If the bidder is identified as both a MBE and WBE, the participation goals shall be deemed to have been met.

In seeking solicitations, bidders are to identify the portion(s) of work to be subcontracted and offer to break down any portion(s) of work into economically feasible units in order to facilitate M/WBE participation. Bidders also are to provide the name of a specific contact person in their notice to the M/WBEs. Contact shall be made prior to bid opening. A list containing the name of each company contacted, the date and method must be submitted with bid documents.

The low bidder shall provide to the City of Peoria, upon request, copies of faxes, letters, and e-mails sent to M/WBEs.

III. Good-Faith Efforts Documentation when Utilizing Subcontractors

- A. All Bidders must provide proof of its compliance with the pre-bid requirements and good-faith efforts to the City. Both the pre-bid documentation and the support documentation requested below must be submitted with bid documents.
 - 1. All Bidders must submit a properly completed “**Subcontractor Utilization Statement.**” All Bidders must provide the scope of work to be performed, the dollar amount to be paid, and the percentage amount of the contract for each company listed.
 - 2. All Bidders must submit a list of qualified M/WBE’s who submitted proposals but will not be utilized. This list must include a justification for not accepting the proposed bid.
- B. Disputes arising from the enforcement of these requirements will be resolved by the Equal Opportunity Office.

IV. Waiver Requirements When Self-Performing All Work

- A. All bidders will make every effort to make subcontract opportunities available to M/WBEs. However, if such an opportunity cannot be made available, the Bidder must seek a waiver by submitting “**M/WBE Participation Waiver Request.**” The waiver request must be submitted to the City of Peoria with bid documents.
- B. For the M/WBE waiver request to receive consideration, the following supportive documentation that applies must accompany the form:
 - 1. A narrative describing the Bidder’s good faith efforts to secure M/WBE participation prior to bid opening.
 - 2. A notarized affidavit attesting the Bidder did not receive inquiries or proposals from qualified M/WBEs in response to the required notification prior to bid opening.

3. A written explanation for why the Bidder believes no subcontracting opportunities exist. ***If the City of Peoria determines that the explanation is insufficient it reserves the right to halt the bid award process to request additional information from the Bidder. The Bidder will receive the request for information in writing.***
4. A written explanation for why the Bidder believes it is impracticable to award any subcontract(s) on the project in question. ***If the Equal Opportunity Office determines that the explanation is insufficient it reserves the right to halt the bid award process to request additional information from the Bidder. The Bidder will receive the request for information in writing.***

V. Change In Use of Subcontractors or Self-Performance Status

Before the General Contractor can deviate from utilizing any of the subcontractors listed on the Subcontractor Utilization Statement or its declared intent to self-perform, it must submit a completed **Notification of Change in Participation** form to the City of Peoria. Upon notification construction on the project may be delayed or halted until a review is conducted by the Equal Opportunity Office.

Regarding a self-performance change, if a subcontracting opportunity has been made available, the General Contractor must identify all good faith efforts made to meet the M/WBE participation goals, unless the change was due to an emergency.

VI. Procedures for Counting M/WBE Participation toward Goals (based upon Department of Transportation regulations)

- i. When an M/WBE participates in a contract, count only the value of the work actually performed by the M/WBE toward M/WBE participation goals.
 1. Count the entire amount of that portion of a construction contract (or other contract not covered by paragraph (i)(2) of this section) that is performed by the M/WBE's own forces. Include the cost of supplies and materials obtained by the M/WBE for the work of the contract including supplies purchased or equipment leased by the M/WBE (except supplies and equipment the M/WBE subcontractor purchases or leases from the prime contractor or its affiliate).
 2. Count the entire amount of fees or commissions performed by an M/WBE firm towards M/WBE goals if that firm provides the

Apparent Low Bidder a bona fide professional, technical, consultant, or managerial service or provides bonds or insurance specifically required in a City of Peoria contract.

3. If an M/WBE subcontracts a portion of its work to an M/WBE, 100% of the value of the subcontracted work may be counted toward the M/WBE goal, but any portion of the work the M/WBE subcontracts to a non-M/WBE does not count toward the M/WBE goal.
 - ii. When an M/WBE participates in a joint venture on a City contract, only count the dollar value of the portion of the work that the M/WBE performs with its own forces toward M/WBE goals.
 - iii. Count expenditures to an M/WBE contractor toward M/WBE goals if, and only if, the M/WBE is performing a commercially useful function on that contract.
 1. An M/WBE performs a commercially useful function when it is responsible for performing, managing, and supervising its contracted work; moreover, with respect to materials and supplies used on the contract, it must also be responsible for negotiating its price, and purchasing and managing those supplies.
 2. An M/WBE does not perform a commercially useful function if its role is limited to that of an extra participant in a transaction, contract, or project through which funds are passed in order to obtain the appearance of M/WBE participation. It should be noted that an effort contrived to give the appearance of M/WBE participation is not considered a good faith effort and is considered an ethical violation that is subject to sanctions outlined in section V.
 3. If an M/WBE does not perform or exercise responsibility for at least 30% of the total cost of its contract with its own work force, you must presume that it is not performing a commercially useful function and the dollar amount of that work will not count toward the M/WBE goals.
 4. When an M/WBE is presumed the City of Peoria not to be performing a commercially useful function as provided in paragraph (iii)(3) of this section, the M/WBE may present evidence to rebut this presumption. Your rebuttal is subject to review by the City of Peoria.

- iv. Use the following factors in determining if an M/WBE trucking company is performing a commercially useful function:
1. The M/WBE trucking company must manage and supervise the trucking work it is being paid to perform. A contrived arrangement for the purpose of giving the appearance of meeting M/WBE goals is not considered a good faith effort.
 2. The M/WBE trucking company must own and operate at least one fully licensed, insured, and operational truck used on the contract.
 3. The M/WBE trucking company receives credit for the total dollar value of the transportation services it provides on the contract using trucks it owns, insures, and operates.
 4. The M/WBE trucking company may lease trucks from another M/WBE trucking firm, including an owner-operator who is certified as an M/WBE. The M/WBE who leases trucks from another M/WBE receives total credit for the dollar value of the transportation services the M/WBE trucking lessee provides on the contract.
 5. The M/WBE trucking company may also lease trucks from a non-M/WBE trucking firm, including an owner-operator. The M/WBE who leases trucks from a non-M/WBE is only entitled to credit for the fee or commission it receives as a result of the lease arrangement. The M/WBE does not receive credit for the total dollar value of the transportation services provided by the lessee since these services are not provided by an M/WBE.
 6. A lease agreement with an M/WBE trucking firm must indicate that the M/WBE has exclusive use of and control over the truck. This does not preclude the leased truck from working for others during the term of the lease with the consent of the M/WBE, so long as the lease gives the M/WBE absolute priority for use of the leased truck. Leased trucks must display the name and identification number of the M/WBE.
- v. Count expenditures with M/WBEs for materials and supplies toward M/WBE goals in the following manner:
1. If the materials or supplies are obtained from an M/WBE manufacturer, count 100% of the cost of the materials or supplies toward M/WBE goals.

Note: For purposes of this paragraph (v)(1), a manufacturer is a firm that operates or maintains a factory or establishment that produces, on the premises, the materials, supplies, articles, or equipment required under the contract and of the general character described by the specifications.

2. If the materials or supplies are purchased from an M/WBE regular dealer, count 60% of the cost of the materials or supplies toward M/WBE goals.

Note: For purposes of this section, a regular dealer is a firm that owns, operates or maintains a store, warehouse, or other establishment in which the materials, supplies, articles or equipment of the general character described by the specifications and required under the contract are brought, kept in stock, and regularly sold or leased to the public in the usual course of business.

(A) To be a regular dealer, the firm must be an established, regular business that engages, as its principal business and under its own name, in the purchase and sale or lease of the products in question.

(B) A person may be a regular dealer in such bulk items as petroleum products, steel, cement, gravel, stone, or asphalt without owning, operating, or maintaining a place of business as provided in this paragraph (v)(2), if the person both owns and operates distribution equipment for the products. Any supplementing of regular dealers' own distribution equipment shall be by a long-term lease agreement and not on an ad hoc or contract-by-contract basis.

(C) Packagers, brokers, manufacturers' representatives, or other persons who arrange or expedite transactions are not regular dealers within the meaning of the paragraph (v)(2).

3. If materials or supplies are purchased from an M/WBE which is neither a manufacturer nor a regular dealer, count only 5% of the contract amount toward the M/WBE goals.

VII. Record Keeping and Reporting

- A. The General Contractor and subcontractors agree to maintain records demonstrative of its good faith efforts to comply with the participation goals attached to the project. This would include, but not limited to, names of M/WBEs and non-minority firms awarded subcontracts, including dollar amount of the contract, payments to subcontractors, and weekly certified payroll reports. These records shall be made available to the City of Peoria.

- B. All information will be provided through ePrismSoft, an electronic web based compliance tracking software. Access to ePrismSoft has been furnished by the City of Peoria. To activate access, the General Contractor and subcontractors must contact Human Capital Development at webnfo@eprismsoft.com or 309/692-6400.

VIII. Sanctions

- A. The Equal Opportunity Office may recommend the rejection of the apparent low bid where the information submitted by the Apparent Low Bidder fails to objectively demonstrate compliance with the M/WBE Good-Faith Efforts requirements. The Apparent Low Bidder will be notified of this decision and the reasons in writing. The Apparent Low Bidder may request a hearing within five (5) business days of this notice. The request must be submitted to the Equal Opportunity Office. The hearing will be held no later than seven (7) business days after receipt of request. The City Manager or designee will conduct all hearings.
- B. Upon a finding that any party has not complied with the provisions of this clause, any one or a combination of the following actions may be taken:
1. Declare the Apparent Low Bidder non-responsive and therefore ineligible for contract award.
 2. Declare the Apparent Low Bidder ineligible for further contracts for a calendar year.
 3. File a formal complaint against Apparent Low Bidder, and/or subcontractor with the Fair Employment and Housing Commission.

org. 05/08/08
rev. 04/17/12

HUMAN RIGHTS ACT

The contract will be subject to and governed by the rules and regulations of the Illinois Human Rights Act, including Public Act 87-1257 (effective July 1, 1993) which requires that every bidder shall have a written sexual harassment policy that includes, at a minimum, the following information:

- a. The illegality of sexual harassment;
- b. The definition of sexual harassment under State law;
- c. A description of sexual harassment, utilizing examples;
- d. The bidder's internal complaint process including penalties;
- e. The legal recourse, investigative and complaint process available through the Illinois Department of Human Rights and the Illinois Human Rights Commission;
- f. Directions on how to contact the Department and the Commission;
- g. Protection against retaliation as provided in the Act.

Bidders are hereby placed on notice, a copy of its policy shall be provided to the Department upon request.

SAXI-93
effective 7-1-93
per Legal Dept.

ROADWORK SPECIAL PROVISIONS

SALVAGING EXISTING MATERIAL

All existing municipally owned street castings, millings and pavement brick, in usable condition within the limits of the improvement shall, if not required for further use in the construction of the improvement, be carefully excavated and preserved by the Contractor. Sidewalk brick shall not be considered pavement brick and the contractor will have the salvage rights to the sidewalk brick removed. Said street castings, millings, and pavement brick shall be separated from other removal materials and hauled by the Contractor to the City's yard on Darst Street. The Contractor shall contact Sie Maroon at 309-645-5139, in advance of hauling salvaged materials to the City's yard on Darst Street.

The cost of salvaging and hauling existing municipally owned street castings, millings and pavement brick, as outlined herein, will not be paid for separately, but the cost shall be included in the contract unit price for the item of construction involved.

CONSTRUCTION DEBRIS

In accordance with Public Act 90-761, the following shall be added to the third paragraph of Article 202.03 of the "Standard Specifications for Road and Bridge Construction":

The Contractor shall not conduct any generation, transportation, or recycling of construction or demolition debris, clean or general or uncontaminated soil generated during construction, remodeling, repair, and demolition of utilities, structures, and roads that is not commingled with any waste, without the maintenance of documentation identifying the hauler, generator, place of origin of the debris or soil, the weight or volume of the debris or soil, and the location, owner, and operator of the facility where the debris or soil was transferred, disposed, recycled or treated. This documentation must be maintained by the Contractor for 3 years.

This documentation shall be included in applicable item of construction and shall not be paid for separately.

EROSION CONTROL

The Contractor shall install erosion control systems as necessary or as directed by the Engineer to prevent sediment from entering the City's storm drainage system or exiting the construction area. Erosion control systems shall be installed as necessary or as directed by the Engineer prior to stockpiling of material on the project site. The Contractor shall be responsible for the cost of cleanup and damages resulting from failure to comply with this provision. This work shall be considered incidental to the affected items of work and no additional compensation will be allowed.

The Contractor shall sweep and return to the work site any soil tracked onto the street by the end of the workday or before four (4) hours has elapsed, whichever is sooner. This work shall be considered incidental to the affected items of work and no additional compensation will be allowed.

EARTH EXCAVATION

This work shall be performed in accordance with the applicable sections of the Standard Specifications for Road and Bridge Construction except for the following:

EARTH EXCAVATION has been provided in the contract quantities for the Sidewalk Participation program to pay for removal of soil at locations where sidewalk does not currently exist. This work will be paid for at the contract unit price per CUBIC YARD for EARTH EXCAVATION; which shall include all labor, tools, and equipment necessary to complete this work as specified.

This work will not be paid for separately at tree removal locations or at locations where existing sidewalks and curbs are to be replaced, per those items' specifications unless otherwise directed by the Engineer.

COMBINATION CURB AND SIDEWALK REMOVAL, SIDEWALK REMOVAL

This work shall consist of the removal of all combination curb/sidewalk and sidewalk as directed by the Engineer. This work shall be done in accordance with Section 440 of the "Standard Specifications for Road and Bridge Construction." Payment for removal and replacement will not be allowed for items removed beyond the limits of construction or those items damaged needlessly by the contractor. The cost of sawing pavement where noted or directed by the engineer shall be incidental to the item of work.

This work will be paid for at the contract unit price per SQUARE FOOT for SIDEWALK REMOVAL and COMBINATION CURB AND SIDEWALK REMOVAL; which shall include saw cutting, removing and disposing of said structure, all labor, tools, materials and equipment necessary to complete this work as specified.

DRIVEWAY PAVEMENT REMOVAL, PAVEMENT REMOVAL

This work shall consist of the removal of all driveway pavement and other pavements as directed by the Engineer. This work shall be done in accordance with Section 440 of the "Standard Specifications for Road and Bridge Construction." Payment for removal and replacement will not be allowed for items removed beyond the limits of construction or those items damaged needlessly by the contractor. The cost of sawing pavement where noted or directed by the engineer shall be incidental to the item of work.

This work will be paid for at the contract unit price per SQUARE YARD for DRIVEWAY PAVEMENT REMOVAL and PAVEMENT REMOVAL; which shall include saw cutting, removing and disposing of said structure, all labor, tools, materials and equipment necessary to complete this work as specified.

BRICK SIDEWALK REMOVAL

This work shall consist of the removal of all brick sidewalk as directed by the Engineer. Brick sidewalk shall be removed so as to not to damage the brick being removed. Payment for removal and replacement will not be allowed for items removed beyond the limits of construction or those items damaged needlessly by the contractor.

The brick shall be separated from other removal materials and hauled by the Contractor to the City's yard on Darst Street in accordance with the specification for Salvaging Existing Materials. The cost of salvaging and hauling pavement brick, will not be paid for separately, but shall be included in the contract unit price for BRICK SIDEWALK REMOVAL.

This work will be paid for at the contract unit price per SQUARE FOOT for BRICK SIDEWALK REMOVAL; which shall include saw cutting, removing and disposing of said structure, all labor, tools, materials and equipment necessary to complete this work as specified.

CURB REMOVAL, COMBINATION CURB & GUTTER REMOVAL

This work shall consist of the removal of all existing curb as directed by the Engineer. This work shall be done in accordance with Section 440 of the "Standard Specifications for Road and Bridge Construction." Payment for removal and replacement will not be allowed for items removed beyond the limits of construction or those items damaged needlessly by the contractor. The cost of sawing pavement where noted or directed by the engineer shall be incidental to the item of work.

This work will be paid for at the contract unit price per FOOT for CURB REMOVAL and COMBINATION CURB & GUTTER REMOVAL which shall include saw cutting, removing and disposing of said structure, all labor, tools, materials and equipment necessary to complete this work as specified.

CONCRETE STEP REMOVAL

This work shall consist of the removal of all P.C.C. Steps as directed by the Engineer. This work shall be done in accordance with Section 440 of the "Standard Specifications for Road and Bridge Construction." Payment for removal and replacement will not be allowed for items removed beyond the limits of construction or those items damaged needlessly by the contractor. The cost of sawing pavement where noted or directed by the engineer shall be incidental to the item of work.

This work will be paid for at the contract unit price per SQUARE FOOT for CONCRETE STEP REMOVAL; which shall include saw cutting, removing and disposing of said structure, all labor, tools, materials and equipment necessary to complete this work as specified. The payment area shall be determined by adding the total height of the rise plus the total length of the run, and taking the sum times the width of the steps, all as indicated on the P.C.C. Step standard detail.

SUBBASE GRANULAR MATERIAL

This item shall be in accordance with applicable portions of Section 311 of the “Standard Specifications for Road and Bridge Construction.”

Locations where existing curb, combination curb & gutter, gutter flag, sidewalk, or combination curb & sidewalk are being removed and replaced – this work shall consist of placing additional Subbase Granular Material, Type B as directed by the Engineer to prepare the sub-base to the proper elevation. This work shall be performed at the discretion of the Engineer. The thickness of aggregate required will vary. This work will be paid for at the contract unit price per TON for SUBBASE GRANULAR MATERIAL, TYPE B.

Locations where new curb, combination curb & gutter, gutter flag, sidewalk, or combination curb & sidewalk are being constructed for the first time - this work shall consist of providing a minimum of four inches (4”) of Subbase Granular Material, Type B having a gradation of CA-6, compacted in place to provide the proper sub-base for curb, combination curb & gutter, gutter flag, sidewalk, and combination curb & sidewalk in accordance with the plans and as directed by the Engineer. This work will be paid for at the contract unit price per TON for SUBBASE GRANULAR MATERIAL, TYPE B.

All excavation required to prepare the sub-grade prior to placement of the granular material will not be paid for separately but included in the cost of the item the granular material is required for.

REMOVAL & DISPOSAL OF UNSUITABLE MATERIAL

This work shall be performed in accordance with section 202 of the “Standard Specifications for Road and Bridge Construction.”

This work shall consist of the excavation, removal and disposal of unsuitable sub-grade material located under the curb, combination curb & gutter, gutter flag, sidewalk, and combination curb & sidewalk. This work shall be performed at the discretion of the Engineer.

This work will be paid for at the contract unit price per CUBIC YARD for REMOVAL AND DISPOSAL OF UNSUITABLE MATERIAL.

CONCRETE CURB, TYPE B

This work will be performed in accordance with Section 606 of the “Standard Specifications for Road and Bridge Construction.”

This work will be paid for at the contract unit price per FOOT for CONCRETE CURB, TYPE B, which shall include all labor, excavation, earth backfill along the back of the curb, materials, curing compound, tools and equipment necessary to complete this work as specified. The cost will also include rubbing the face of the curb to create a clean finish.

P.C.C. COMBINATION CURB AND SIDEWALK, 4”

This work shall consist of an integrally poured Portland cement concrete combination curb/sidewalk as in accordance with Section 424 of the “Standard Specifications for Road and Bridge Construction” and the City Standard for Combination Concrete Curb & Sidewalk 4”. *The basis of payment shall be the area in square feet of the top surface of the curb and sidewalk for each property and will not include the front finished face of curb.*

This work will be paid for at the contract unit price per SQUARE FOOT for P.C.C. COMBINATION CURB AND SIDEWALK, 4” which shall include all labor, excavation, earth backfill along the back of sidewalk, materials, curing compound, tools and equipment necessary to complete this work as specified.

P.C.C. SIDEWALK, 4”

This work will be performed in accordance with Section 424 of the “Standard Specifications for Road and Bridge Construction” and City Standards.

The method of measurement shall be the total exposed surface area of the walk in square feet for each property.

This work will be paid for at the contract unit price bid per SQUARE FOOT for P.C.C. SIDEWALK, 4”., which shall include all labor, excavation, earth backfill along the sidewalk, curing compound, tools and equipment necessary to complete this work as specified.

P.C.C. DRIVEWAY PAVEMENT, 6” & 8”

This work shall consist of constructing a 6” & 8” P.C.C. driveway pavement as directed by the Engineer. Provisions shall be made for satisfactory transition between the proposed driveway pavement and the existing pavement to remain in place. This work shall be in accordance with applicable portions of Section 423 of the “Standard Specifications for Road and Bridge Construction.”

The method of measurement shall be the total exposed surface area of the driveway in square yards for each property.

This work shall be paid for at the contract unit price per SQUARE YARD of P.C.C. DRIVEWAY PAVEMENT, 6” or P.C.C. DRIVEWAY PAVEMENT, 8”, which shall include all labor, earth backfill, granular backfill, materials, curing compound, tools and equipment necessary to complete this work as specified.

COMBINATION CONCRETE CURB & GUTTER

This work shall be in accordance with Section 606 of the Standard Specifications, special details included with the contract documents, and as directed by the Engineer. The combination curb & gutter shall be formed on both the front and back, and the curb portion shall have the same curved face as the existing curb. A minimum of one expansion joint shall be installed per each section of curb & gutter replacement and as detailed in the plans.

As soon as the concrete has cured enough so as to not cause marring or other damage to the concrete, the Contractor shall saw-cut contraction joints in the curb at intervals not to exceed 15'. When combination concrete curb and gutter is poured adjacent to the sidewalk, the Contractor shall ensure that the expansion and contraction joints match the sidewalk joints to prevent random cracking.

This work shall be paid for at the contract unit price per FOOT for COMBINATION CONCRETE CURB & GUTTER, regardless of the type required, which shall include all labor, excavation, earth backfill, curing compound, material, & equipment necessary to complete the work. Curing compound shall be applied to all exposed surface and will be considered incidental to this item of work.

P.C.C. STEPS

This work shall be done in accordance with applicable portions of Section 423 of the "Standard Specifications for Road and Bridge Construction."

This work shall consist of construction steps at locations indicated by the engineer in accordance with the City Standard for P.C.C. Steps. The steps shall be constructed with IDOT Class SI Concrete as shown in Section 1020 of the "Standard Specifications for Road and Bridge Construction".

This work shall be paid for at the contract unit price per square foot determined by adding the total height of the rise plus the total length of the run, and taking the sum times the width of the steps, all as indicated on the P.C.C. Step standard detail.

This work shall be paid for at the contract unit price per SQ FOOT of P.C.C. STEPS which shall include all labor, excavation, earth backfill, granular material, materials including wire, curing compound, tools and equipment necessary to complete this work as specified. The cost will also include rubbing the face of the steps to create a clean finish.

INCIDENTAL HOT-MIX ASPHALT SURFACING (SPECIAL)

This item will be constructed in accordance with section 408 of the "Standard Specifications for Road and Bridge Construction", except that all necessary BITUMINOUS MATERIALS (PRIME COAT) and AGGREGATE (PRIME COAT) will be included in the cost of this item. The work will consist of sawing and milling a minimum of 3" in depth and one foot from the face of curb or outside edge of gutter flag, in the areas disturbed during removal, disposal of asphalt, grading and compacting base if necessary, applying the prime coat, and placing 3" of Hot-Mix Asphalt Surface Course. This work will also consist of placing concrete base course or aggregate base course at the direction of the engineer if needed to fill the void between the new sidewalk and existing pavement. This work will not be paid for separately but included in the cost of the Incidental Hot-Mix Asphalt Surfacing (Special).

The work will be paid for at the contract unit price per SQ FT for INCIDENTAL HOT-MIX ASPHALT SURFACING (SPECIAL), which shall include all saw cutting, removal, prime, concrete base course, aggregate base course, excavation, labor, tools, materials and equipment necessary to complete the work as specified.

CURING COMPOUND

This item shall be furnished and applied in accordance with Article 1020.13 of the "Standard Specifications" except as herein provided.

Curing Compound shall be applied to all exposed Portland Cement Concrete Surfaces.

This work will not be paid for separately but shall be included in the cost of the item of the construction bid.

CONCRETE FIBERS

The contractor may use micro-fibers in lieu of the welded wire mesh. The micro-fibers and dosage rate shall be approved by the engineer prior to use. The dosage rate shall meet the recommendations of the supplier. The micro-fibers shall be supplied by an IDOT approved supplier of synthetic fibers.

Concrete fibers will not be paid for separately but shall be included in the cost of the concrete item.

SEEDING AND MULCHING

This work shall consist of broadcasting Class I (Lawn Mixture) seed over all earthen areas disturbed by construction in accordance with Article 250 of the Standard Specifications. All seeded areas shall immediately be mulched using Method 1 in accordance with Article 251 of the Standard Specifications.

Seeding and Mulching will not be paid for separately unless otherwise Specified, but shall be considered incidental to the construction contract.

SIDEWALK RAMPS FOR THE DISABLED

Sidewalk ramps shall be constructed per ADA requirement. Details of ramps are per Highway Standard 424001-07, 424006-01, 424011-01, 424016-02, 424021-01, 424026-01, and 424031-01. Any variation in the shape of curbs and sidewalk or needed landscaping of dirt at a corner to accommodate ramps for the handicapped shall not be paid for separately, but shall be considered incidental to the item of construction involved.

This work will be paid for at the contract unit price per SQUARE FOOT of P.C.C. COMBINATION CURB & SIDEWALK, 4" or P.C.C. SIDEWALK 4".

Any side curb poured integrally with a ramp will be paid for at the contract unit price per SQUARE FOOT OF P.C.C. COMBINATION CURB & SIDEWALK 4"; except where Monolithic Side Curb has been called for in the plans. The square footage will not include the exposed vertical surface areas of the side curbs.

Concrete Curb, Type B & Combination Concrete Curb & Gutter along the roadway will be paid for at the contract unit price per FOOT. Detectable warnings will be paid for at the contract unit price per SQUARE FOOT. There shall be a minimum of four inches of concrete placed below the panels.

DETECTABLE WARNINGS

This work shall consist of a 24-inch strip of the Federal Standard color 30166, brick red, as its standard of detectable warning in the direction of travel and shall extend the full width of the curb ramp or flush surface. This work shall conform to the details given in the plans and in accordance with Section 424 of the "Standard Specifications for Road and Bridge Construction".

Detectable warnings shall be installed at all designated ADA ramps per the appropriate IDOT curb ramp standard.

The following will be the acceptable construction techniques.

1. Cast-in-Place truncated dome ramps must be formed with a rigid mold. Every area of the tool shall be tamped directly above the stamp to form a uniform appearance. The concrete used shall be Class X (SI) concrete that has the Federal Standard color 22144, brick red, the entire depth. Broadcasting brick red dye or painting the sidewalk brick red **will not** be acceptable methods.
2. DetecTile PFC Composite truncated dome panels. Panels must be the Federal Standard color 22144, brick red. Panels shall be placed within the Class X (SI) concrete. They shall have a minimum of four anchors per ceramic panel to secure the panels to the concrete ramp.
3. Armor-Tile Tactile Systems manufactured Diamond-Hard Vitrified Polymer truncated panels. Panels must be the Federal standard color 22144, brick red, unless otherwise approved by the Engineer.
4. Pre-Cast concrete truncated dome ramp panels. The panels shall be a minimum of 2-inches thick with the entire depth consisting of Class X (SI) concrete that is Federal Standard color 22144, brick red. The pre-cast panels shall have wire mesh or fiber mesh reinforcement. Tapered edges or holes so that dowel reinforcement rod can be placed within the insert shall be acceptable methods. These shall be placed before placing the rest of the ramp so that they are tightly secured into place.
5. TufTile Polymer detectable warning surfaces. Panels must be the Federal standard color 22144, brick red, unless otherwise approved by the Engineer.

Final determination of acceptability shall be the responsibility of the Engineer.

THESE FIVE METHODS ARE THE ONLY ACCEPTABLE MEANS FOR TRUNCATED DOME RAMPS WITHIN THE CITY OF PEORIA.

Detectable Warnings will be paid for at the contract unit price per square foot of surfacing, which shall include all labor, tools, materials and equipment necessary to complete the work as specified.

TIE BARS & DOWEL BARS

All tie bars required for sidewalk, curb, or pavement will not be paid for separately but included in the cost of the item the tie bars are required for. Any dowel bars required will not be paid for separately but included in the cost of the item required for.

TOPSOIL, COMPOST & MULCH, FURNISH & PLACE, SPECIAL

This work shall consist of providing a layer of eight (8) inches deep by two (2) foot wide, 7 parts soil and 1 part compost mixed semi-homogeneously, that is suitable for planting and cultivating at one specific location as directed by the Engineer. Wood chip mulch shall be installed over the top of this topsoil to a standardized depth of 1-inch. The mulch shall be free of sticks or pieces that are longer than 6 inches or wider than 1-inch diameter.

This assembly shall be installed at-grade with the surface of sidewalk and blended to match the existing grade at the point 2 feet away from the sidewalk.

Grass seed shall **not** be applied to the top of this soil.

This item is not incidental earth backfill, but is dedicated for one site. Earth backfill placed alongside all other sidewalks and driveways shall be installed per those SIDEWALK or DRIVEWAY specifications.

This work will be paid at the contract unit price per SQUARE YARD for TOPSOIL, COMPOST & MULCH, FURNISH & PLACE, SPECIAL which shall include all labor, materials, tools and equipment necessary to complete this work as specified.

RELOCATE EXISTING RETAINING WALLS

This work shall consist of the removal and resetting of landscape type retaining walls constructed along the property lines at the back of existing sidewalks. Specifically, this work is proposed at 623 Fairholm Avenue, to mechanically pick up the wall sections, move them to a safe area, perform sidewalk replacement, then move the wall sections back into place.

The Contractor shall exercise care to prevent any disturbance to any such existing walls. These specified locations and any other locations found to be in conflict by the Contractor must be verified with the Engineer's Representative before any removal takes place. The Engineer's Representative shall confirm the removal limits with the Contractor before removal. Any removals performed without prior notification and agreement of the Engineer's Representative shall be done and reconstructed without payment by the City. The Contractor shall reconstruct the wall with the salvaged material or new material of equal type and quality at the agreed location.

This work will be paid for at the contract unit price per SQUARE FOOT of wall face (not including top surface) for RELOCATE EXISTING RETAINING WALLS.

TREE REMOVAL, OVER 15 UNITS

This work shall consist of the removal of trees per IDOT Standard Specification Section 201. Specifically, this work is proposed at 1812 N Peoria Avenue, for a tree that is immediately adjacent to the property's driveway approach.

The Contractor shall exercise care to prevent any disturbance to any such existing underground and overhead utilities. These specified locations and any other locations found to be in conflict by the Contractor must be verified with the Engineer's Representative before any removal takes place. The Engineer's Representative shall mark the tree for removal with paint. Any removals performed without prior notification and agreement of the Engineer's Representative shall be done and reconstructed without payment by the City.

The Contractor shall backfill the stump area with 12" soil, suitable for growing grass.

This work will be paid for at the contract unit price per UNIT for TREE REMOVAL OVER 15 UNITS, which shall include all labor, earth backfill, root cutting, materials, tools and equipment necessary to complete this work as specified.

APPENDIX A

EEO DOCUMENTS

READ THIS PAGE BEFORE FILLING OUT THE EMPLOYER REPORT CC-1 OR THE RENEWAL APPLICATION

This page outlines the instructions you need to follow to process either the Employer Report Form CC-1 or the Renewal Application. Forms that are not filled out properly will not be processed.

Processing Fee: Effective January 1st, 2006, in accordance with recent changes to chapter 17 of the Peoria Municipal Code, a fifty-dollar (\$50.00) processing fee will be charged with each submission of the Employer Report Form CC-1 and the Renewal Application. The only exception to payment of the processing fee is neighborhood associations.

Method of Processing Fee Payment: The City of Peoria Treasurer's office will only accept check, money order, and cash payment. Make checks payable to the "City of Peoria".

Who needs to fill out the Employer Report Form CC-1 or the Renewal Application? Any business providing a good or service to the City for remuneration or any business receiving financial assistance from the City.

Under what legal authority does the City of Peoria require this application? The filing requirement is authorized under chapter 17, Peoria Municipal Code, section 17-120(b).

Which form do I submit?

Employer Report Form CC-1: If your company has not received an EEO Certification Number from the City of Peoria, you need to complete the Employer Report Form CC-1. You will also need to submit a copy of your company's **Sexual Harassment Policy** (for specific instructions on the sexual harassment policy, see the Sexual Harassment Policy Information Sheet).

Renewal Application: If your company currently has an EEO Certification Number from the City of Peoria that has expired, or is about to expire, you only need to complete the Renewal Application form. If you are submitting the Renewal Application you do not need submit the Sexual Harassment Policy as it is already on file.

Submittal Instructions: Either **mail** or **hand deliver** your completed materials.

Mail: Mail forms and payment to the Office of Equal Opportunity. The EO Office will review the forms. If they are complete and correct, the EO Office will process your forms and mail, fax, or email you a copy of your EEO certificate. Send forms and payment to:

City of Peoria
Office of Equal Opportunity
419 Fulton Street, Room 303
Peoria, IL 61602-1276

Hand Delivery: If you choose to hand deliver your forms and payment, you must first go to the Office of Equal Opportunity (address listed above). The EO Office will review your form for completeness and then ask you to stop by the Treasurer's Office, City Hall Building, Room 100 to make your Processing Fee payment. The EO office will process your forms and mail, fax, or email you a copy of your EEO certificate.

If you have any questions, call the Equal Opportunity Office at (309) 494-8530

KEEP THIS PAGE FOR YOUR RECORDS



MINORITY AND WOMEN BUSINESS ENTERPRISE DIRECTORY

To assist Bidders in their outreach efforts, the City of Peoria has developed a Minority and Women Business Enterprise (M/WBE) directory. Go to the City's website at <http://www.peoriagov.org/equal-opportunity/minority-and-women-business-enterprise-mwbe-directory/> to view the directory.

EQUAL EMPLOYMENT OPPORTUNITY

To be awarded a contract all Suppliers, Vendors and Contractors to the City of Peoria must be registered in the City of Peoria's Contract Compliance Program and have a current EEO Certification Number. This program is unrelated to any State or Federal program. To obtain or renew a number, an Employer Report Form CC-1, a copy of your company's sexual harassment policy statement, if a first time applicant and a Fifty-dollar (\$50.00) processing fee must be submitted to the City of Peoria. Go to the City's website at <http://www.peoriagov.org/equal-opportunity/> to obtain the form and instructions page.

Note: Suppliers, Vendors and Contractors do not need an EEO Certification Number to submit a bid proposal. However, it is required prior to the award of the contract.



MINORITY AND FEMALE WORKFORCE UTILIZATION

The City of Peoria is committed to ensuring our construction projects offer equal employment opportunity to all the citizens we serve. The Prime Contractor and all of its subcontractors are to make a good faith effort to comply with the following goals for minority and female workforce utilization.

1. Eighteen (18) percent of the total hours worked, per trade, should be performed by minority workers.
2. Three (3) percent of the total hours worked, per trade, should be performed by female workers.

Each contractor must maintain certified payroll records verifying the hours worked by minority and female workers. These records must be provided to the City of Peoria. For directions on submitting this information, see Minority and Women's Business Enterprise (M/WBE) Participation Requirements for Good-Faith Efforts, Section VII.

CONTRACT DELIVERABLES

CITY OF PEORIA SUBCONTRACTOR PAYMENT FORM

PRIME CONTRACTOR

Name: _____
 Address: _____
 Phone: _____
 Contact Person: _____

PROJECT

Name: _____
 Pay Estimate No: _____
 Percent Complete: _____ %
 Work Period: _____ to _____

INSTRUCTIONS: Complete the table below. If additional space is needed attach extra pages as needed and included all information listed in the table below; along with project name and prime contractor.

Subcontractor <i>(Name)</i>	Payment Amount	Payment Type <i>(F-full/ P-partial)</i>
	\$	
	\$	
	\$	
	\$	
	\$	
	\$	
	\$	
Total Payment Amount for Work Completed	\$	

This form is to verify the work completed and the amount paid to a subcontractor utilized on the above listed project. Under penalty of law for perjury or falsification, the undersigned certifies that the payment reported herein was made to the subcontractors listed.

 Signature of Prime Contractor

 Date

CITY OF PEORIA MONTHLY WORKFORCE ANALYSIS

Check appropriate status

Month Ending _____

Contractor

Subcontractor

Name: _____

Address: _____

Contact Person: _____

Phone: _____

Project: _____

Date Work Started: _____

Percent Complete: _____ %

Job Categories	Number of Employees				Hours of Employment									
	Total # of Employees		Total Minorities		African American		Asian/Pacific Islander		American Indian/Alaskan Native		Hispanic		White	
	M	F	M	F	M	F	M	F	M	F	M	F	M	F
Foremen														
Electricians														
Glaziers														
Iron Workers														
Laborers														
Teamsters														
Millwrights														
Pipe Fitters														
Plumbers														
Plasterers														
Painters														
Roofers														
Operating Engs														
Tile Layers														
Sheet Metal Wkrs														
TOTALS														

Instructions: The total number of hours worked on the project (Hours of Employment), and the total number of individuals working on the project during the reporting period (Number of Employees) should be submitted on this form to the Project Resident Engineer every month. Each contractor and subcontractor should submit with this form certified payroll records for the period covered. The prime contractor is responsible for securing and submitting with his/her report, reports from all subcontractors.

**CITY OF PEORIA
NOTIFICATION OF CHANGE IN PARTICIPATION**

Type of Change

Date: _____

_____ Subcontractor. Complete Part 1
_____ Self-Performance. Complete Part 2

PRIME CONTRACTOR

PROJECT

Name: _____
Address: _____
Phone: _____

Name: _____

PART 1

If changing from previously identified subcontractor to another, complete both From and To.

From Name _____
Address _____

To Name _____
Address _____

Phone _____
Status _____ MBE _____ WBE _____ Non-M/WBE

Phone _____
Status _____ MBE _____ WBE _____ Non-M/WBE
Contract Amount _____

Will scope of work change? _____ Yes _____ No

Describe change _____

Reason for Contractor Change _____

PART 2

Complete if deviating from intent to self-perform.

Prime Contractor will have to hire another contractor to perform work. _____ Yes _____ No

Change was due to _____ Emergency _____ Non-Emergency

Explain Situation _____

Describe good faith efforts to utilize M/WBE _____

Name of added Contractor _____
Address _____

Phone _____
Status _____ MBE _____ WBE _____ Non-M/WBE
Scope of Work _____

Contract Amount _____

Signed: _____

Contractor

Title

MISCELLANEOUS

CITY OF PEORIA
CONTRACT

This agreement, made and entered into this _____ day of _____, 2016, by and between the City of Peoria, an Illinois Municipal Corporation, Party of The First Part, and _____, Party of The Second Part for the improvement known as the _____;

WITNESSETH: That for and in consideration of the payments and agreements mentioned in the proposal hereto attached, to be made and performed by the Party of the First Part, and according to the terms expressed in the bond referring to these presents, the Party of The Second Part agrees with said Party of The First Part, at his/their own proper cost and expense to furnish and deliver all the work, materials and supplies in accordance with the specifications contained in said proposal, and in full compliance with all the terms of this agreement, for the amount of _____ (\$ _____).

IT IS UNDERSTOOD AND AGREED that the instructions to bidders, proposal, bid, specifications, performance bond and maintenance bond are component parts of this contract and shall be deemed a part hereof. It is also understood and agreed that the contractor shall not assign, transfer, convey or otherwise dispose of this contract, or his right to execute it, or his right, title or interest in or to it or any part thereof, unless the previous written consent of the City Manager of the City of Peoria shall first be obtained thereto.

EMPLOYEE/EMPLOYMENT RESTRICTIONS – THE CONTRACTOR:

THE CONTRACTOR (hereinafter referred to as "SERVICE PROVIDER") agrees, as a condition of accepting this contract with the City of Peoria, that, for a period of one (1) year following completion of this contract, it shall be prohibited from hiring, directly or indirectly, any City employee or official who was involved, directly or indirectly in: (1) the selection and/or recommendation to select the SERVICE PROVIDER for performance of this contract; (2) coordinating the efforts of the SERVICE PROVIDER in the consummation or completion of this contract; or (3) monitoring or determining the performance of the SERVICE PROVIDER. The SERVICE PROVIDER further acknowledges and agrees that, upon the City's determination that a violation of this provision has occurred, the penalty imposed, at the sole discretion of the City, may include one or more of the following: (1) cancellation of any other contract(s) between the City of Peoria and the SERVICE PROVIDER; (2) disqualification of the SERVICE PROVIDER from bidding or being awarded future contracts with the City of Peoria for a period of two [2] years; and/or (3) payment of liquidated damages to the City of Peoria in the amount of TWENTY FIVE THOUSAND DOLLARS (\$25,000.00).

IN WITNESS WHEREOF, the said parties have executed these presents on the date above mentioned.

THE CITY OF PEORIA

BY: _____
City Manager

ATTEST: _____
City Clerk

EXAMINED AND APPROVED:

Corporation Counsel

PARTY OF THE SECOND PART

(name of individual, firm, or corporation)

BY: _____
(member of firm or officer of corporation)

(If a Co-Partnership)

(seal)
(seal)

Partners doing business under the firm name
of _____ (seal)
(Party of the second part)
(If an Individual)

(seal)

(Party of the second part)

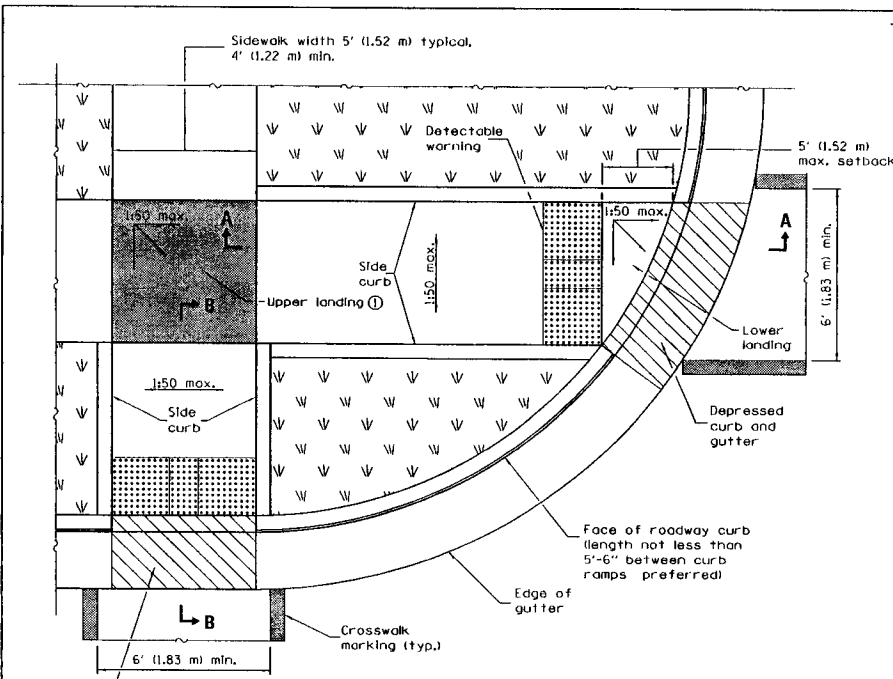

RAMPS IN LANDSCAPED AREA
SETBACK ≤ 5'

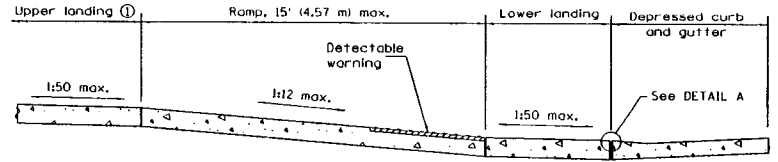

SECTION A-A

① Upper landing not required for ramp slopes flatter than 1:20.

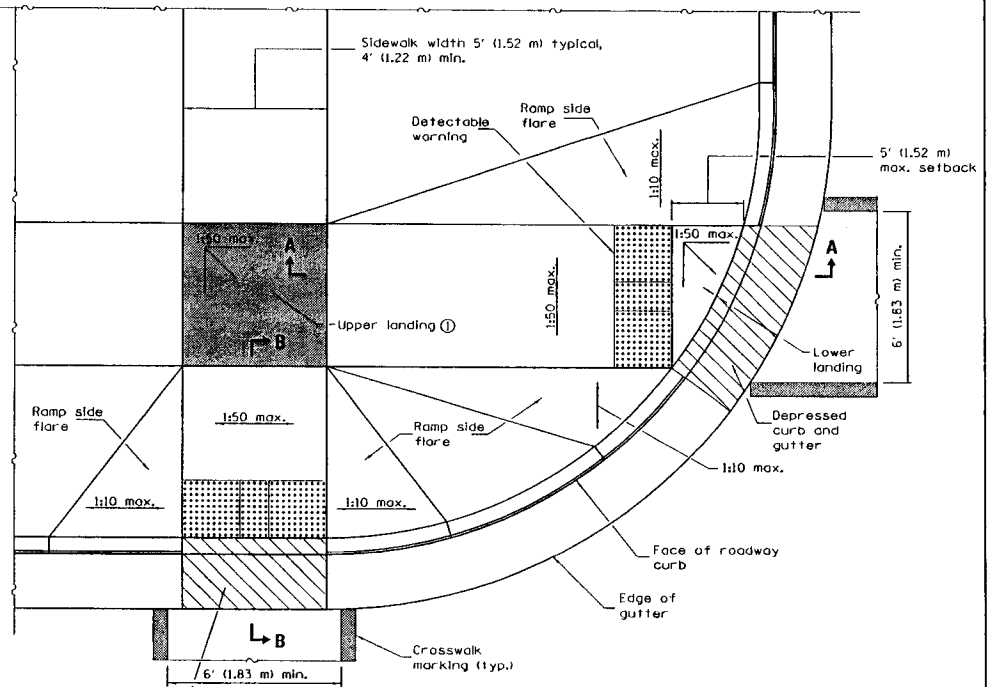

RAMPS IN PAVED AREA
SETBACK ≤ 5'

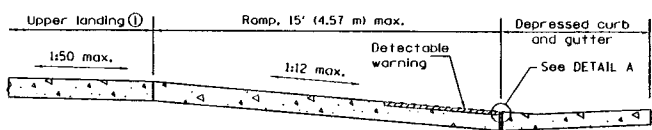

SECTION B-B

① Upper landing not required for ramp slopes flatter than 1:20.

GENERAL NOTES

All slope ratios are expressed as units of vertical displacement to units of horizontal displacement (V:H).

Where 1:50 maximum slope is shown, 1:64 is preferred.

See Standard 606001 for details of depressed curb adjacent to curb ramp.

All dimensions are in inches (millimeters) unless otherwise shown.

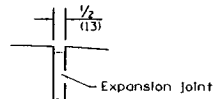

DETAIL A

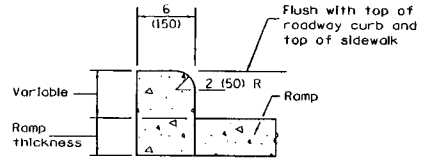

SIDE CURB DETAIL

Illinois Department of Transportation

PASSED January 1, 2013

Michael Beard
ENGINEER OF POLICY AND PROCEDURES

APPROVED January 1, 2013

ENGINEER OF DESIGN AND ENVIRONMENT

14-11-CEPSSS

DATE	REVISIONS
1-1-13	Widened crosswalk markings to 6' (1.83 m) min. inside dimension. Rev. Gen. Notes.
1-1-12	Completely revised and renamed standard.

PERPENDICULAR CURB RAMPS FOR SIDEWALKS
(Sheet 1 of 2)

STANDARD 424001-07

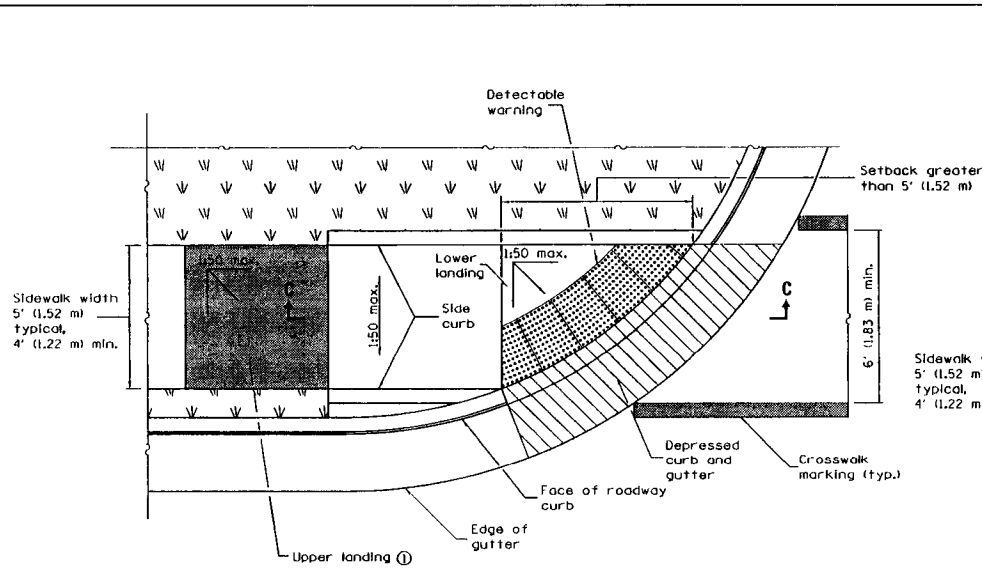

**RAMP IN LANDSCAPED AREA
SETBACK > 5'**

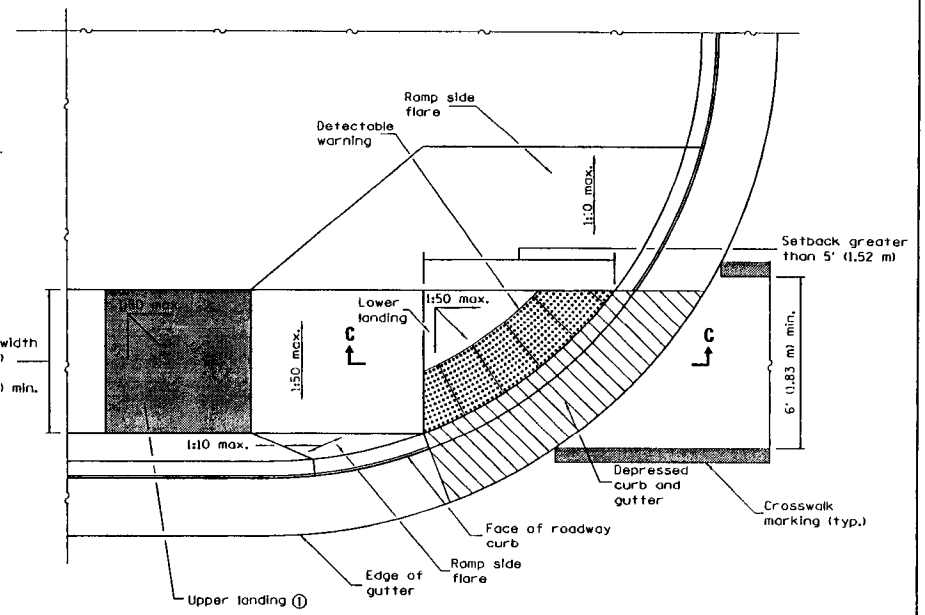

**RAMP IN PAVED AREA
SETBACK > 5'**

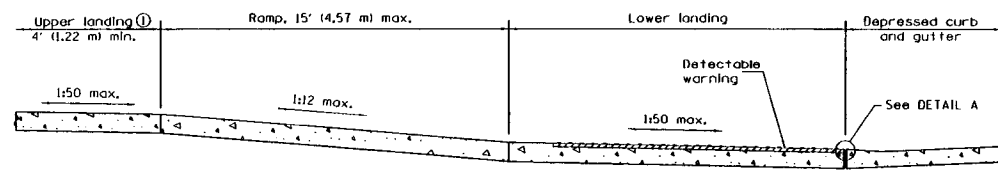

SECTION C-C

① Upper landing not required for ramp slopes flatter than 1:20.

Illinois Department of Transportation
 PASSED January 1, 2013
 ENGINEER OF POLICY AND PROCEDURES
 APPROVED January 1, 2013
 ENGINEER OF DESIGN AND ENVIRONMENT

**PERPENDICULAR CURB RAMPS
FOR SIDEWALKS**
 (Sheet 2 of 2)
STANDARD 424001-07

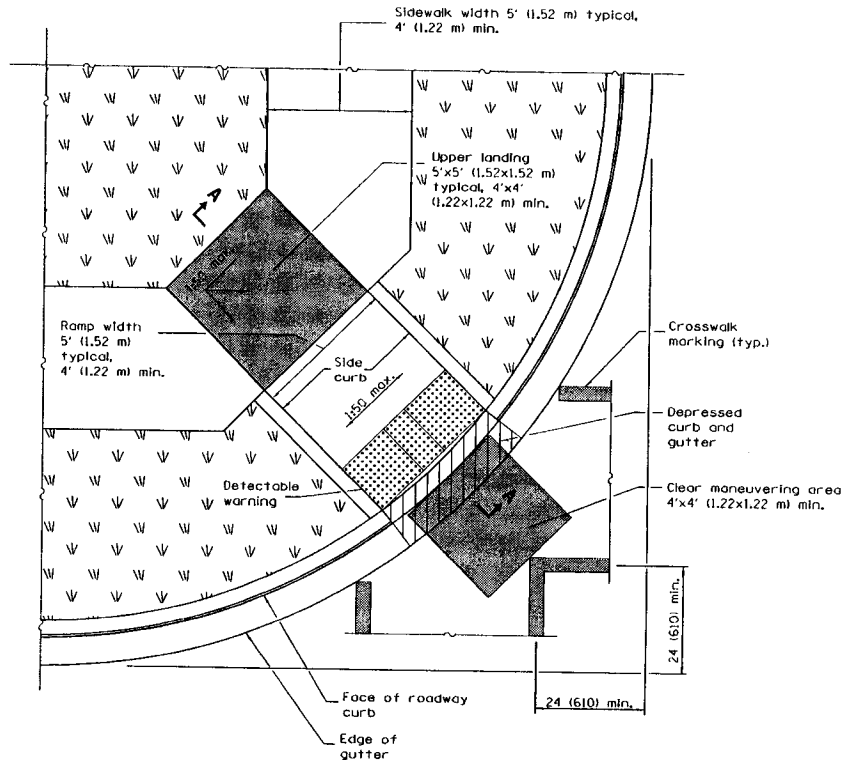

RAMP IN LANDSCAPED AREA

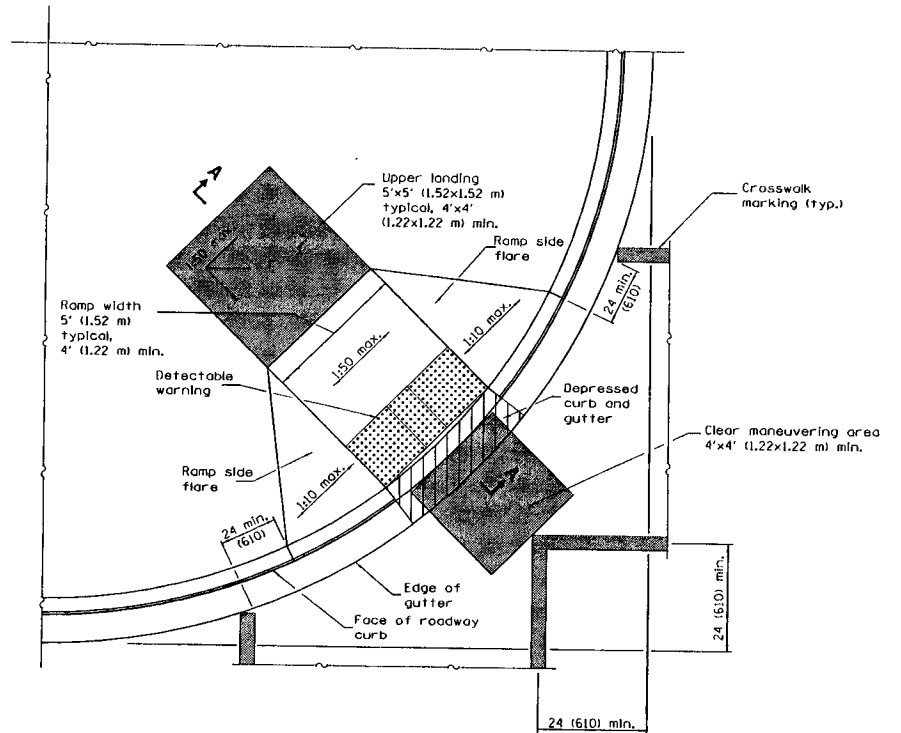

RAMP IN PAVED AREA

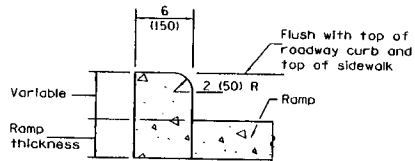

SIDE CURB DETAIL

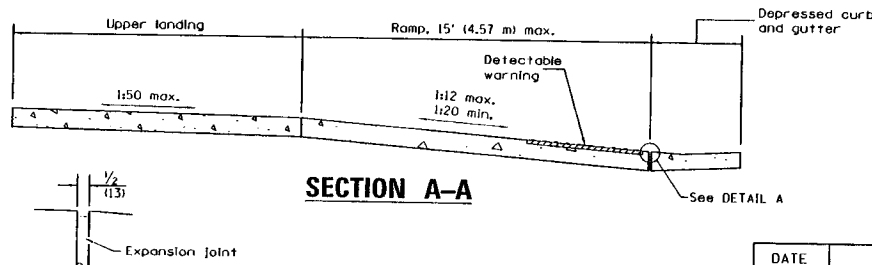

SECTION A-A

DETAIL A

GENERAL NOTES

This Standard shall only be used for curb radii of 20 ft. (6.1 m) or greater.

Where 1:50 maximum slope is shown, 1:64 is preferred.

All slope ratios are expressed as units of vertical displacement to units of horizontal displacement (V:H).

See Standard 606001 for details of depressed curb adjacent to curb ramp.

All dimensions are in inches (millimeters) unless otherwise shown.

Illinois Department of Transportation	
PASSED	January 1, 2013
Michael Bond ENGINEER OF POLICY AND PROCEDURES	
APPROVED	January 1, 2013
ENGINEER OF DESIGN AND ENVIRONMENT	

DATE	REVISIONS
1-1-13	Revised General Notes.
1-1-12	New standard.

DIAGONAL CURB RAMPS FOR SIDEWALKS

STANDARD 424006-01

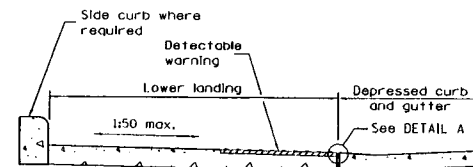
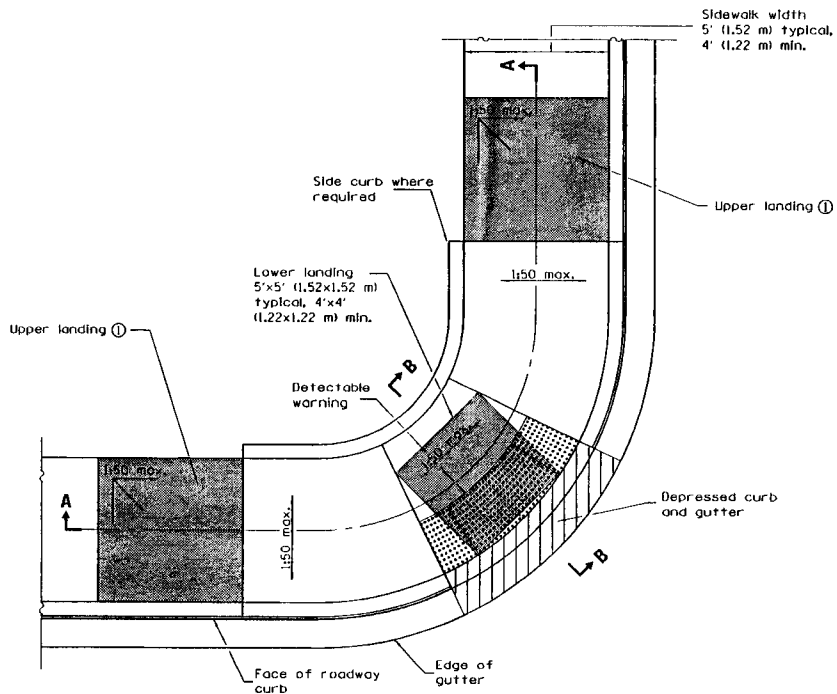

SECTION B-B

CORNER PARALLEL CURB RAMP

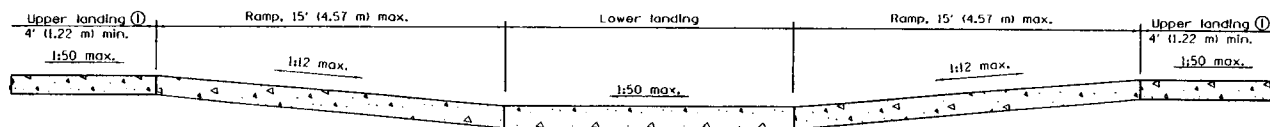

SECTION A-A

① Upper landing(s) not required for ramp slopes flatter than 1:20.

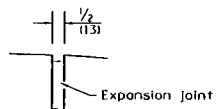

DETAIL A

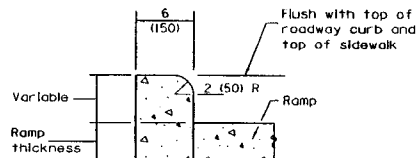

SIDE CURB DETAIL

GENERAL NOTES

All slope ratios are expressed as units of vertical displacement to units of horizontal displacement (V:H).

Where 1:50 maximum slope is shown, 1:64 is preferred.

See Standard 606001 for details of depressed curb adjacent to curb ramp.

All dimensions are in inches (millimeters) unless otherwise shown.

DATE	REVISIONS
1-1-13	Revised General Notes.
1-1-12	New standard.

CORNER PARALLEL CURB RAMPS FOR SIDEWALKS

STANDARD 424011-01

Illinois Department of Transportation

PASSED *Michael B. Bond* 2013
ENGINEER OF POLICY AND PROCEDURES

APPROVED *Michael B. Bond* 2013
ENGINEER OF DESIGN AND ENVIRONMENT

ISSUED 1-1-12

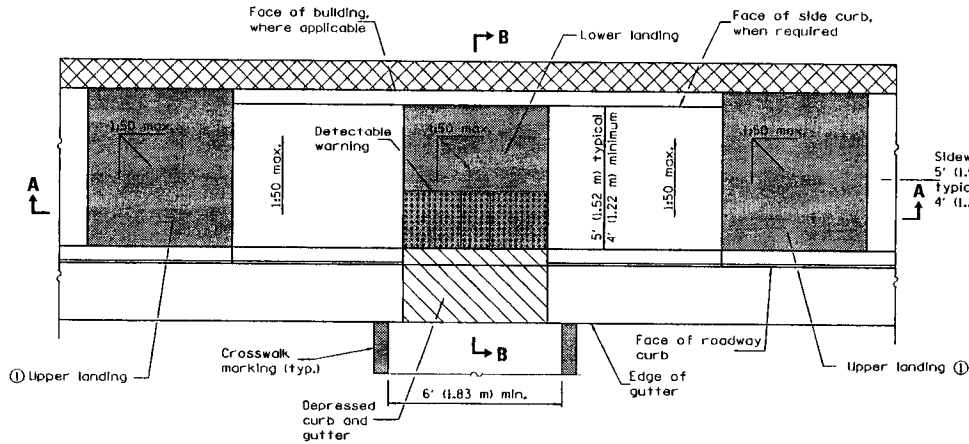

PARALLEL MID-BLOCK CURB RAMP

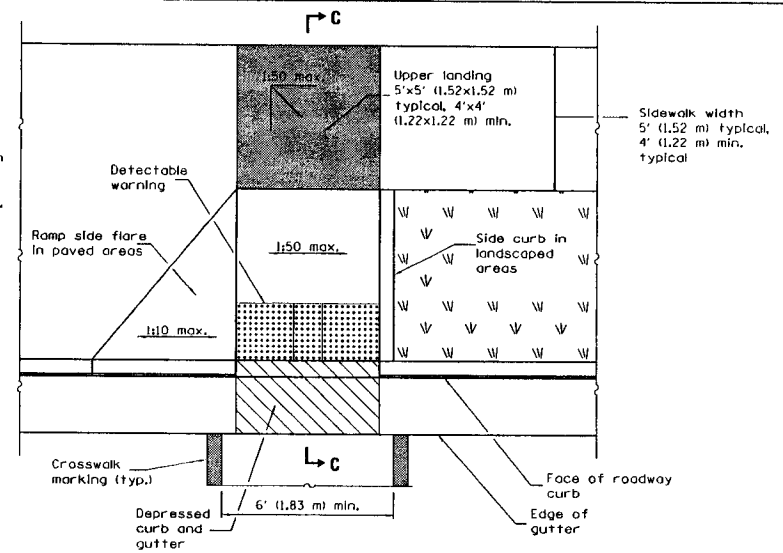

PERPENDICULAR MID-BLOCK CURB RAMP

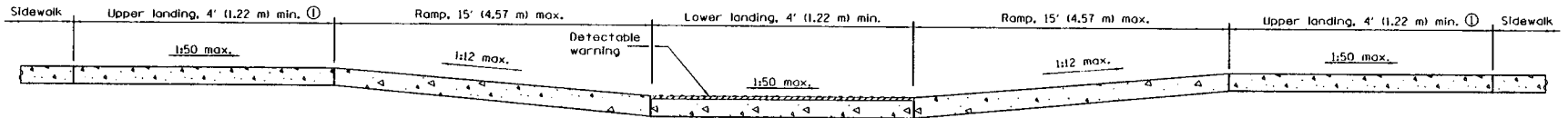

SECTION A-A

① Upper landing(s) not required for ramp slopes flatter than 1:20.

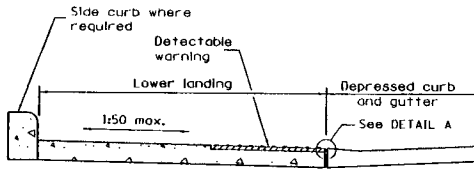

SECTION B-B

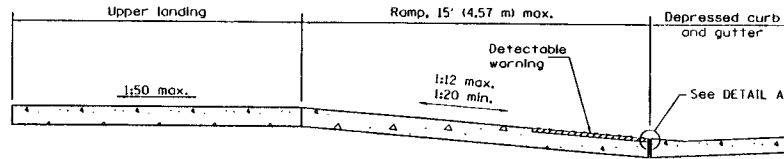

SECTION C-C

GENERAL NOTES

All slope ratios are expressed as units of vertical displacement to units of horizontal displacement (V:H).

Where 1:50 maximum slope is shown, 1:64 is preferred.

See Standard 606001 for details of depressed curb adjacent to curb ramp.

All dimensions are in inches (millimeters) unless otherwise shown.

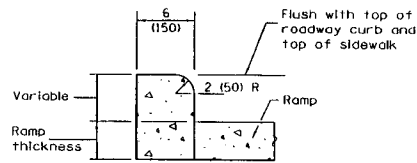

SIDE CURB DETAIL

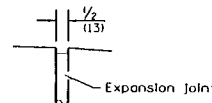

DETAIL A

DATE	REVISIONS
1-1-13	Widened crosswalk markings to 6' (1.83 m) min. inside dimension. Rev. Gen. Notes.
1-1-12	New standard.

MID-BLOCK CURB RAMPS FOR SIDEWALKS

STANDARD 424016-01

Illinois Department of Transportation

PASSED January 1, 2013

Michael Beard
ENGINEER OF POLICY AND PROCEDURES

APPROVED January 1, 2013

[Signature]
ENGINEER OF DESIGN AND ENVIRONMENT

ISSUED 1-1-12

Sidewalk width 5' (1.52 m) typical, 4' (1.22 m) min.

Upper landing ① full width of sidewalk by 4' (1.22 m) min.

Side curb where required

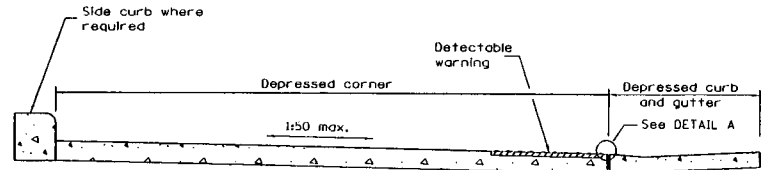
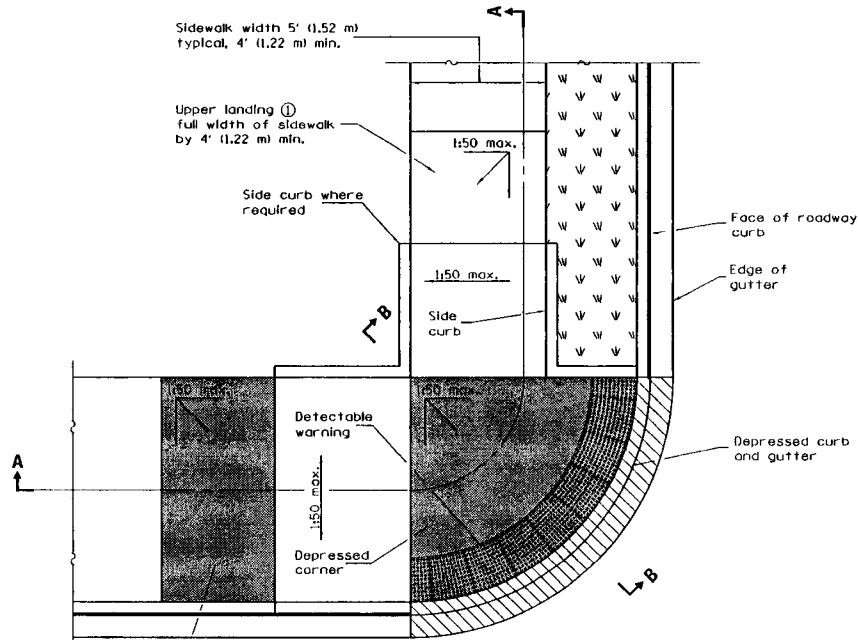

SECTION B-B

DEPRESSED CORNER

① Upper landing full width of sidewalk by 4' (1.22 m) min.

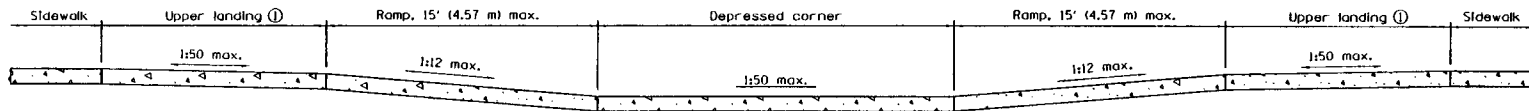

SECTION A-A

① Upper landing(s) not required for ramp slopes flatter than 1:20.

GENERAL NOTES

This standard shall only be used for curb radii of 6 ft. (1.83 m) or greater.

All slope ratios are expressed as units of vertical displacement to units of horizontal displacement (V:H).

Where 1:50 maximum slope is shown, 1:64 is preferred.

See Standard 606001 for details of depressed curb adjacent to curb ramp.

All dimensions are in inches (millimeters) unless otherwise shown.

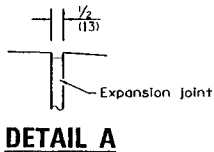

DETAIL A

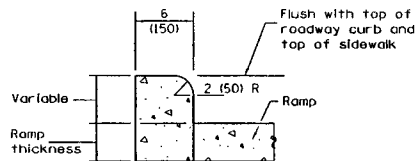

SIDE CURB DETAIL

DATE	REVISIONS
1-1-14	Revised sidewalk width.
	Revised gen. notes to limit curb rad. to 6' (1.83 m) min.
1-1-13	Revised General Notes.

DEPRESSED CORNER FOR SIDEWALKS

STANDARD 424021-02

Illinois Department of Transportation

PASSED January 1, 2014

Michael Beard
ENGINEER OF POLICY AND PROCEDURES

APPROVED January 1, 2014

ENGINEER OF DESIGN AND ENVIRONMENT

ISSUED 1-1-13

② Detectable warning shall only be installed at entrances/alleys with permanent traffic control devices (i.e. stop signs, signals),

③ Where possible, maintain the grade of the sidewalk across the entrance/alley to avoid the need for ramps and upper landings.

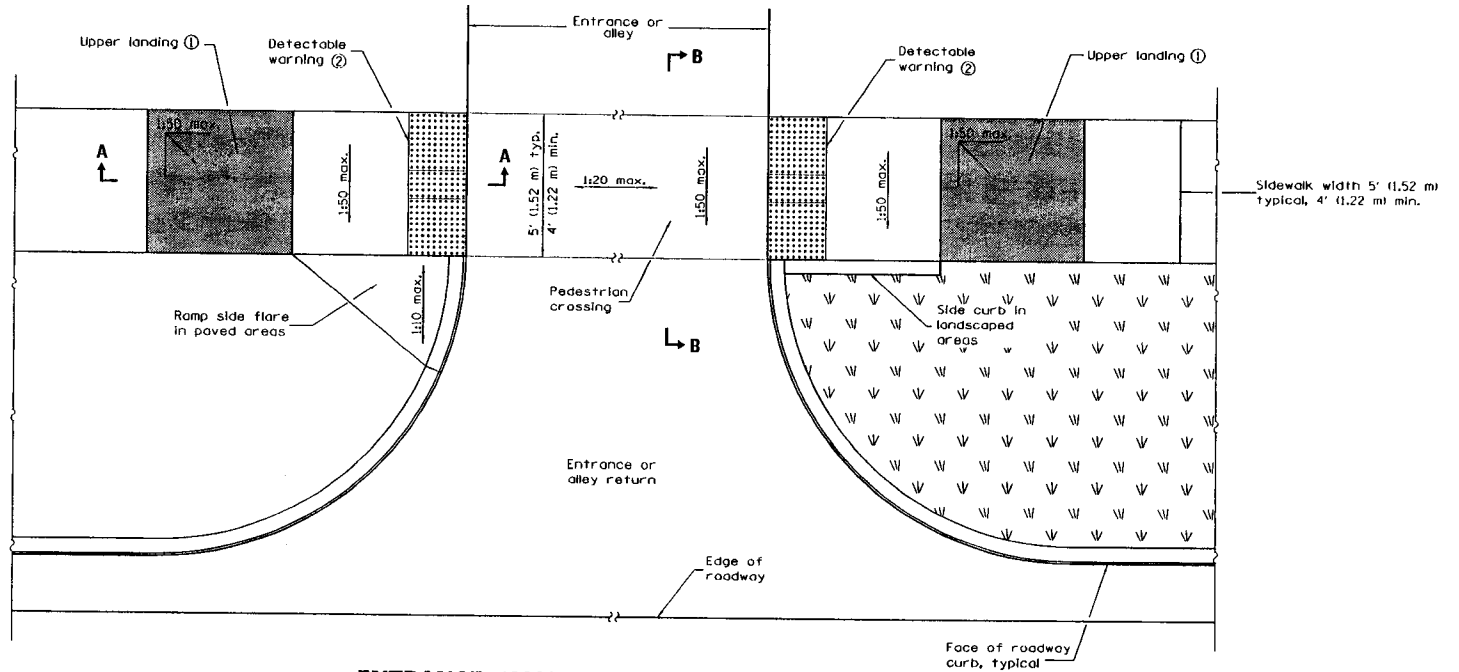

ENTRANCE / ALLEY PEDESTRIAN CROSSING

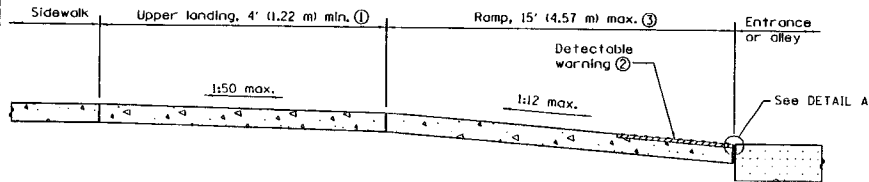

SECTION A-A

① Upper landing not required for ramp slopes flatter than 1:20.

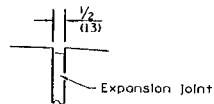

DETAIL A

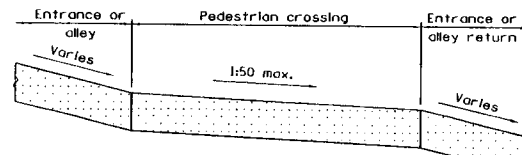

SECTION B-B

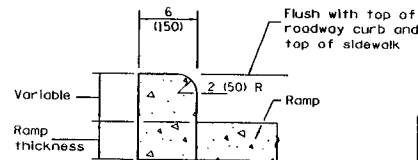

SIDE CURB DETAIL

GENERAL NOTES

All slope ratios are expressed as units of vertical displacement to units of horizontal displacement (V:H).

Where 1:50 maximum slope is shown, 1:64 is preferred.

All dimensions are in inches (millimeters) unless otherwise shown.

DATE	REVISIONS
1-1-13	Revised General Notes.
1-1-12	New standard.

ENTRANCE / ALLEY PEDESTRIAN CROSSINGS

STANDARD 424026-01

Illinois Department of Transportation

PASSED January 1, 2013

Michael Beard
ENGINEER OF POLICY AND PROCEDURES

APPROVED January 1, 2013

ENGINEER OF DESIGN AND ENVIRONMENT

ISSUED 1-1-12

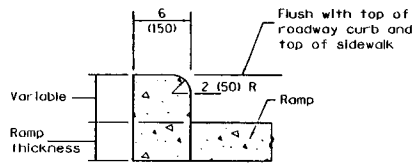

SIDE CURB DETAIL

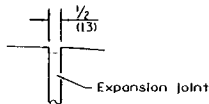

DETAIL A

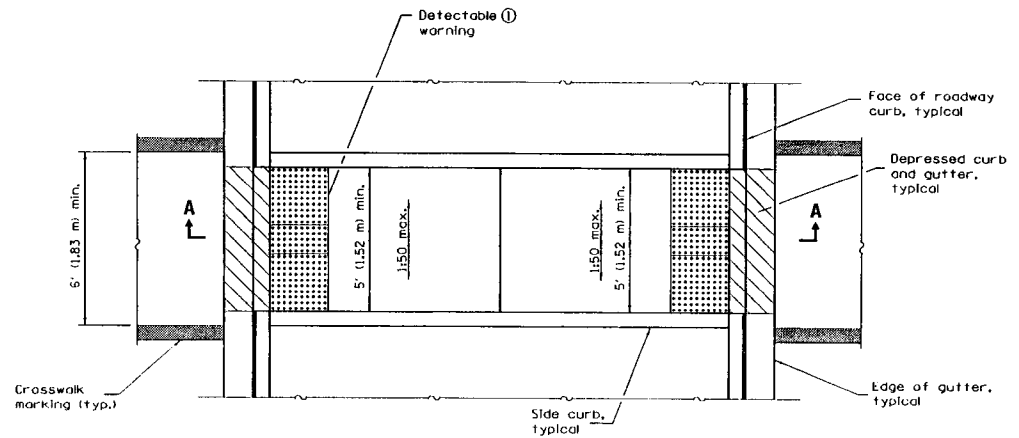

MEDIAN PEDESTRIAN CROSSING

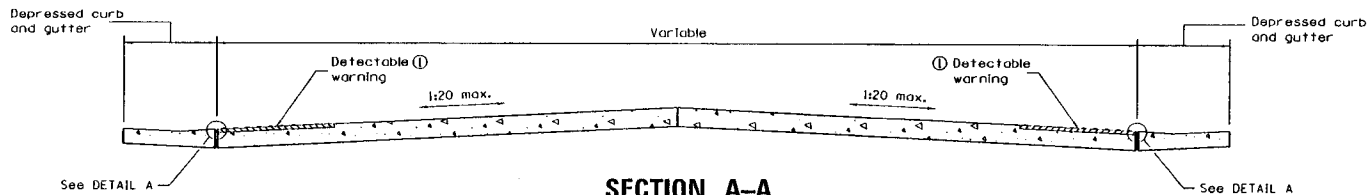

SECTION A-A

① Omit detectable warnings when distance between back of curbs is less than 6' (1.83 m).

GENERAL NOTES

All slope ratios are expressed as units of vertical displacement to units of horizontal displacement (V:H).

Where 1:50 maximum slope is shown, 1:64 is preferred.

See Standard 606001 for details of depressed curb adjacent to curb ramp.

All dimensions are in inches (millimeters) unless otherwise shown.

Illinois Department of Transportation

PASSED January 1, 2013
Michael Beard
 ENGINEER OF POLICY AND PROCEDURES

APPROVED January 1, 2013
[Signature]
 ENGINEER OF DESIGN AND ENVIRONMENT

21-1-17 (REVISED)

DATE	REVISIONS
1-1-12	Widened crosswalk to 6' (1.83 m) min. inside dimension.
	Revised General Notes.
1-1-12	New standard.

MEDIAN PEDESTRIAN CROSSINGS

STANDARD 424031-01

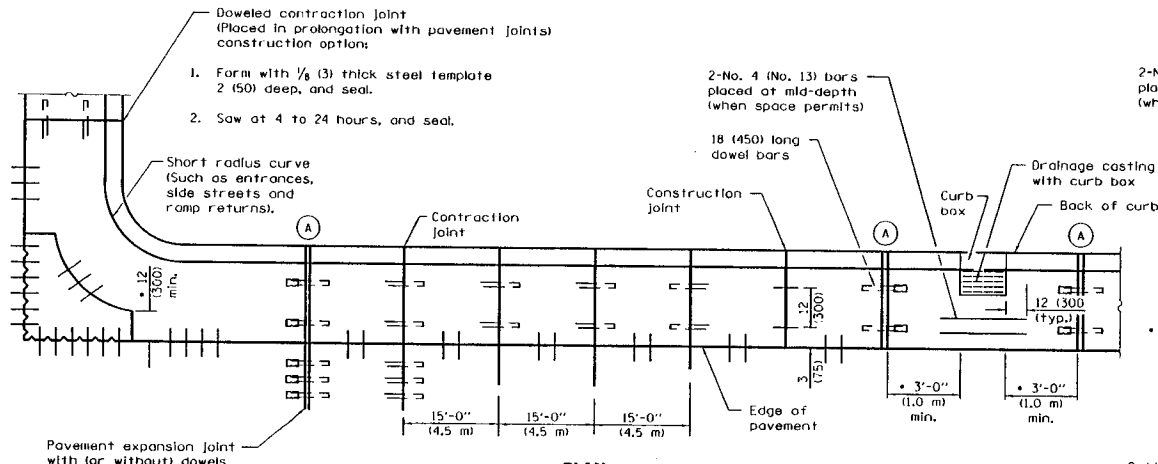

PLAN
ADJACENT TO PCC PAVEMENT OR PCC BASE COURSE

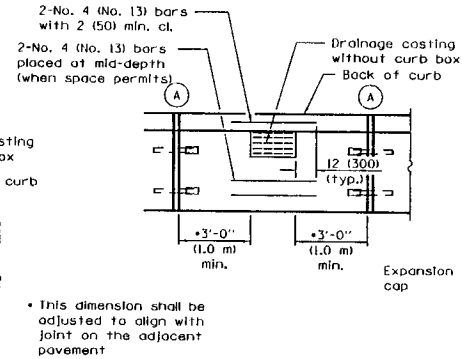

• This dimension shall be adjusted to align with joint on the adjacent pavement

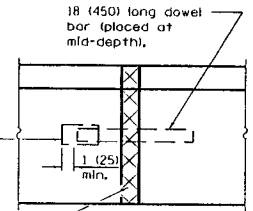

DETAIL A
EXPANSION JOINT

Full depth & width 1 (25) - thick (min.) preformed expansion joint filler.

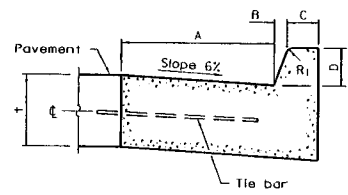

BARRIER CURB

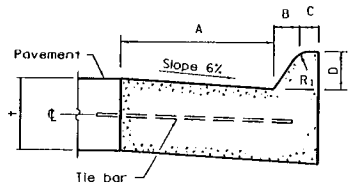

MOUNTABLE CURB

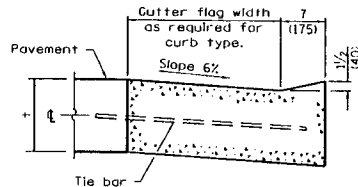

DEPRESSED CURB (TYPICAL)

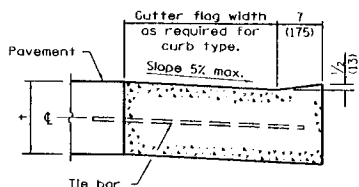

DEPRESSED CURB ADJACENT TO CURB RAMP ACCESSIBLE TO THE DISABLED

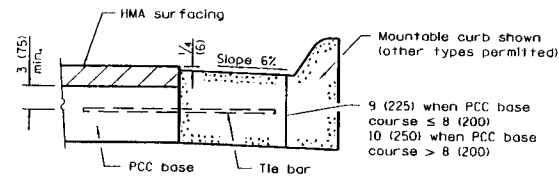

ADJACENT TO PCC BASE COURSE WITH HMA SURFACING

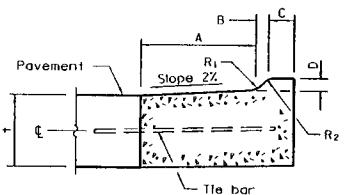

M-2.06 (M-5.15) and M-2.12 (M-5.30)

TABLE OF DIMENSIONS BARRIER CURB					
TYPE	A	B	C	D	R ₁
B-6.12	12	1	6	6	1
(B-15.3)	(300)	(25)	(150)	(150)	(25)
B-6.18	18	1	6	6	1
(B-15.45)	(450)	(25)	(150)	(150)	(25)
B-6.24	24	1	6	6	1
(B-15.60)	(600)	(25)	(150)	(150)	(25)
B-9.12	12	2	5	9	1
(B-22.30)	(300)	(50)	(125)	(225)	(25)
B-9.18	18	2	5	9	1
(B-22.45)	(450)	(50)	(125)	(225)	(25)
B-9.24	24	2	5	9	1
(B-22.60)	(600)	(50)	(125)	(225)	(25)

TABLE OF DIMENSIONS MOUNTABLE CURB							
TYPE	A	B	C	D	R ₁	R ₂	
M-2.06	6	2	4	2	3	2	
(M-5.15)	(150)	(50)	(100)	(50)	(75)	(50)	
M-2.12	12	2	4	2	3	2	
(M-5.30)	(300)	(50)	(100)	(50)	(75)	(50)	
M-4.06	6	4	3	4	3	NA	
(M-10.15)	(150)	(100)	(75)	(100)	(75)	NA	
M-4.12	12	4	3	4	3	NA	
(M-10.30)	(300)	(100)	(75)	(100)	(75)	NA	
M-4.18	18	4	3	4	3	NA	
(M-10.45)	(450)	(100)	(75)	(100)	(75)	NA	
M-4.24	24	4	3	4	3	NA	
(M-10.60)	(600)	(100)	(75)	(100)	(75)	NA	
M-5.06	6	6	2	6	2	NA	
(M-15.15)	(150)	(150)	(50)	(150)	(50)	NA	
M-6.12	12	6	2	6	2	NA	
(M-15.30)	(300)	(150)	(50)	(150)	(50)	NA	
M-6.18	18	6	2	6	2	NA	
(M-15.45)	(450)	(150)	(50)	(150)	(50)	NA	
M-6.24	24	6	2	6	2	NA	
(M-15.60)	(600)	(150)	(50)	(150)	(50)	NA	

GENERAL NOTES

The bottom slope of combination curb and gutter constructed adjacent to pcc pavement shall be the same slope as the subbase or 6% when subbase is omitted.

t = Thickness of pavement.

Longitudinal joint tie bars shall be No. 6 (No. 19) at 24 (600) centers in accordance with details for longitudinal construction joint shown on Standard 420001.

A minimum clearance of 2 (50) between the end of the tie bar and the back of the curb shall be maintained.

The dowel bars shown in contraction joints will only be required for monolithic construction.

All dimensions are in inches (millimeters) unless otherwise shown.

DATE	REVISIONS
1-1-13	Added general note regarding requirement for dowel bars.
1-1-09	Switched units to English (metric).

CONCRETE CURB TYPE B AND COMBINATION CONCRETE CURB AND GUTTER
(Sheet 1 of 2)

STANDARD 606001-05

Illinois Department of Transportation
 PASSED January 1, 2013
 ENGINEER OF POLICY AND PROCEDURES
 APPROVED January 1, 2013
 ENGINEER OF DESIGN AND ENVIRONMENT

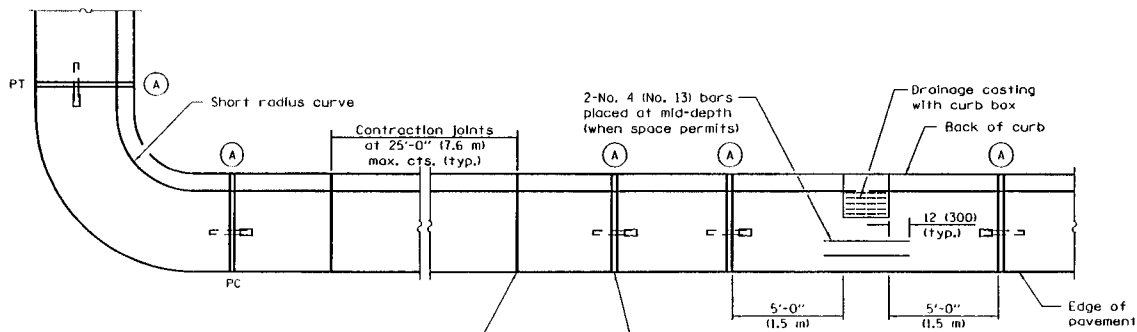

Undoweled contraction joint (typ.) construction options:

1. Form with $\frac{1}{8}$ (3) thick steel template 2 (50) deep, and seal.
2. Saw 2 (50) deep at 4 to 24 hours, and seal.
3. Insert $\frac{3}{4}$ (20) thick preformed joint filler full depth and width.

PLAN

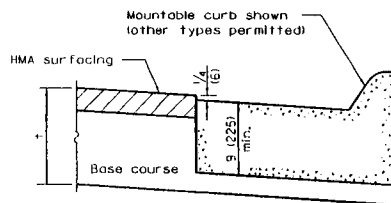
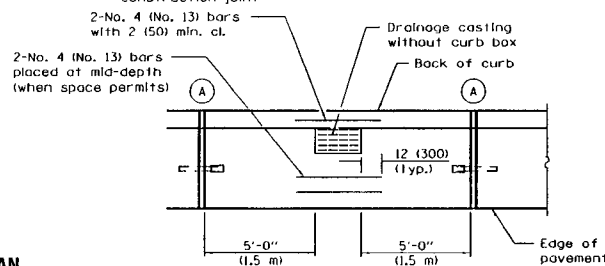

ON DISTURBED SUBGRADE

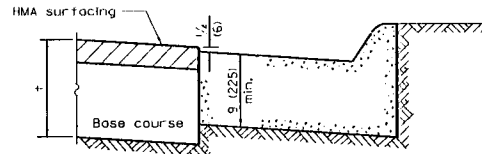

ON UNDISTURBED SUBGRADE

ADJACENT TO FLEXIBLE PAVEMENT

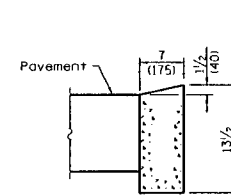

DEPRESSED CURB

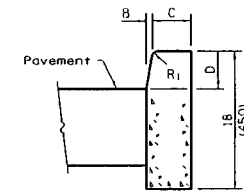

BARRIER CURB

ADJACENT TO FLEXIBLE PAVEMENT

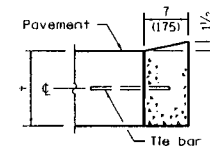

DEPRESSED CURB

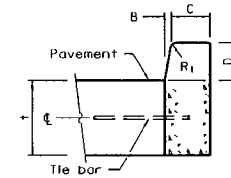

BARRIER CURB

ADJACENT TO PCC PAVEMENT OR PCC BASE COURSE

CONCRETE CURB TYPE B

**CONCRETE CURB TYPE B
AND COMBINATION
CONCRETE CURB AND GUTTER**
(Sheet 2 of 2)

STANDARD 606001-05

Illinois Department of Transportation

PASSED January 1, 2013

Michael Beard
ENGINEER OF POLICY AND PROCEDURES

APPROVED January 1, 2013

ENGINEER OF DESIGN AND ENVIRONMENT

ISSUES 1-1-16

DESIGNER NOTES:
1. THIS DRAWING SHOULD BE USED IN CONJUNCTION WITH STATE STANDARD 42400 AND DISTRICT CADD STD. - CURB RAMPS ACCESSIBLE TO THE DISABLED.

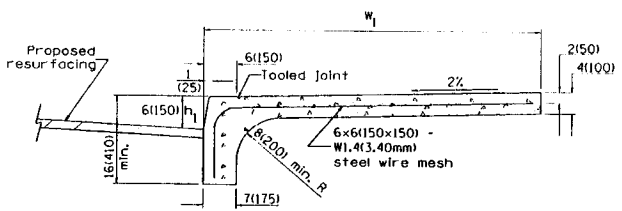

COMBINATION CURB - SIDEWALK 4"(100mm)
Measurement Formula: $(W_1 + h_1) \times \text{length constructed} = \text{Payment area}$
In square meters/square feet

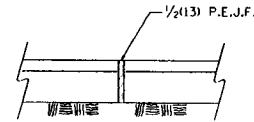
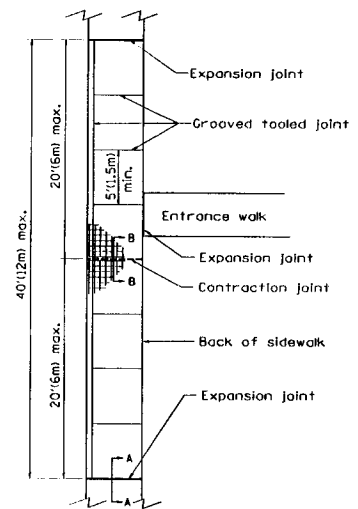

SEC. A-A
Expansion Joint

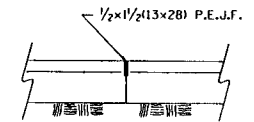

SEC. B-B
Contraction Joint

GENERAL NOTES:

1. All provisions in Section 424 of the Standard Specifications shall apply, unless otherwise shown.

All dimensions are in inches (millimeters) unless otherwise noted.

01-01-97	REHM, A-5.02, NEW REVISION BOX	T.R.
10-16-06	REVISED TO 2007 SPEC.	M.A.

STATE OF ILLINOIS
DEPARTMENT OF TRANSPORTATION

COMBINATION CONCRETE CURB-SIDEWALK 4" (100mm)
NOT TO SCALE

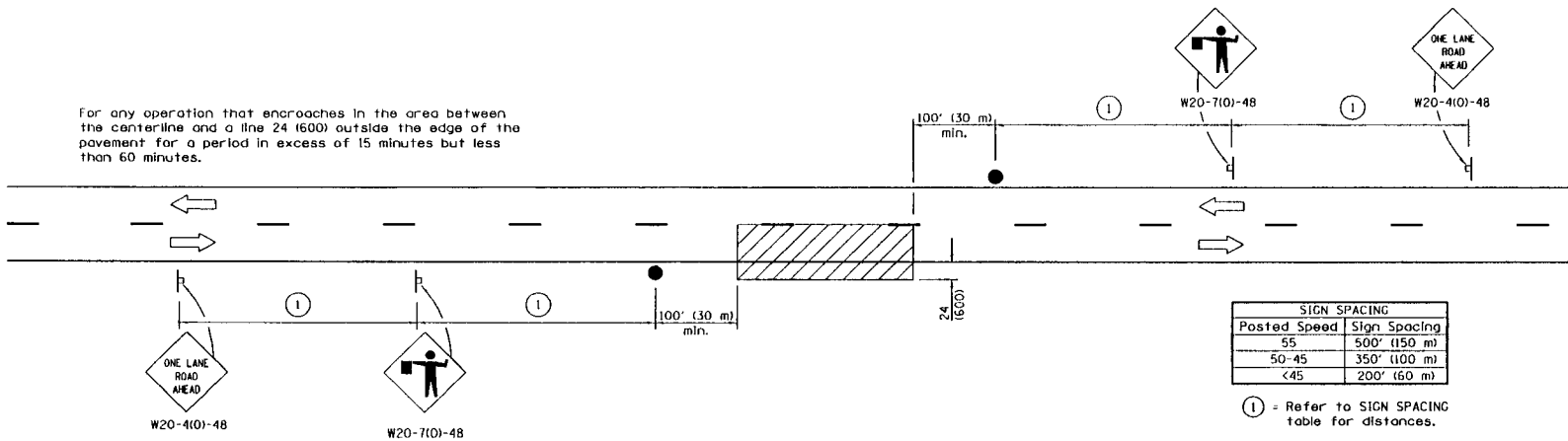
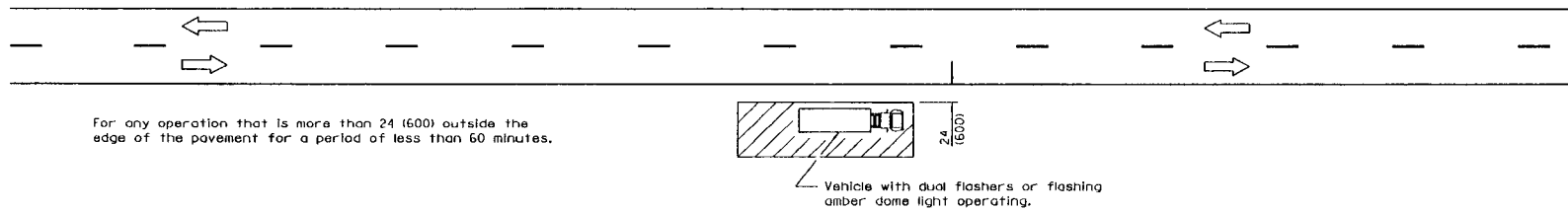
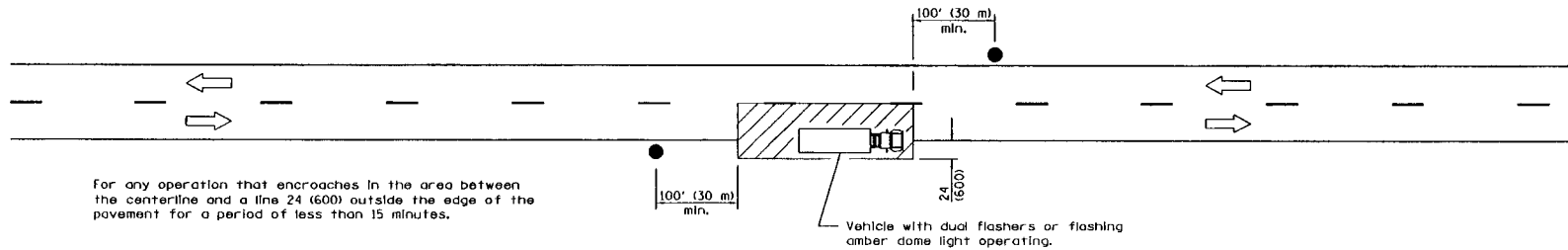

TYPICAL APPLICATIONS

- Marking patches
- Field survey
- String line
- Utility operations
- Cleaning up debris on pavement

SYMBOLS

- Work area
- Sign on portable or permanent support
- Flagger with traffic control sign

All dimensions are in inches (millimeters) unless otherwise shown.

Illinois Department of Transportation

APPROVED January 1, 2011
Thomas J. Kelly
 ENGINEER OF SAFETY ENGINEERING

APPROVED January 1, 2011
Scott S. Cox
 ENGINEER OF DESIGN AND ENVIRONMENT

ISSUE 1-1-11

DATE	REVISIONS
1-1-11	Revised flagger sign.
1-1-09	Switched units to English (metric).

**LANE CLOSURE, 2L, 2W,
SHORT TIME OPERATIONS**

STANDARD 701301-04

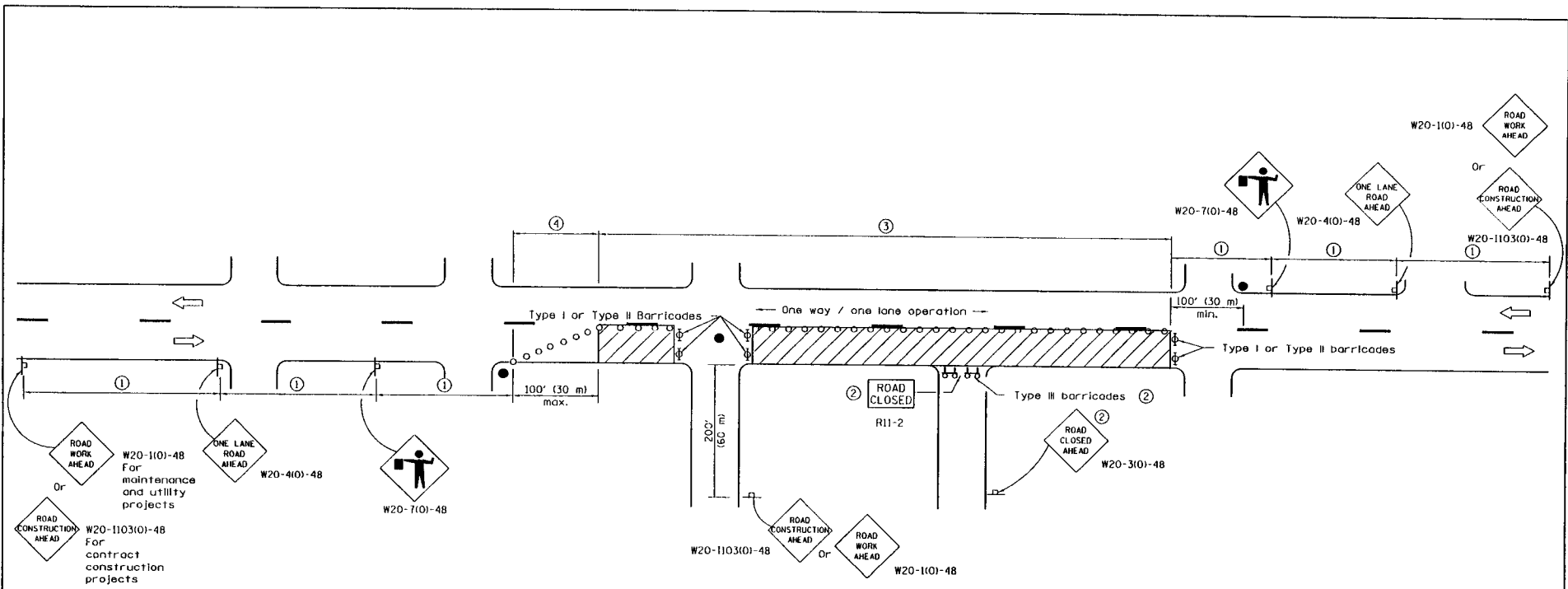

SIGN SPACING	
Posted Speed	Sign Spacing
55	500' (150 m)
50-45	350' (100 m)
<45	200' (60 m)

SYMBOLS

- Work area
- Cone, drum or barricade (not required for moving operations)
- Sign on portable or permanent support
- Flagger with traffic control sign
- Barricade or drum with flashing light
- Type III barricade with flashing lights

- ① Refer to SIGN SPACING TABLE for distances.
- ② For approved shoulder closures.
- ③ Cones at 25' (8 m) centers for 250' (75 m). Additional cones may be placed at 50' (15 m) centers. When drums or Type I or Type II barricades are used, the interval between devices may be doubled.
- ④ Cones, drums or barricades at 20' (6 m) centers.

GENERAL NOTES

This Standard is used where at any time, day or night, any vehicle, equipment, workers or their activities encroach on the pavement requiring the closure of one traffic lane in an urban area.

All dimensions are in inches (millimeters) unless otherwise shown.

Illinois Department of Transportation

APPROVED January 1, 2011

 ENGINEER OF SAFETY ENGINEERING

APPROVED January 1, 2011

 ENGINEER OF DESIGN AND ENVIRONMENT

(6-1)-1 (03/05/11)

DATE	REVISIONS
1-1-11	Revised flagger sign.
1-1-09	Switched units to English (metric). Corrected sign No.'s.

**URBAN LANE CLOSURE,
2L, 2W, UNDIVIDED**

STANDARD 701501-06

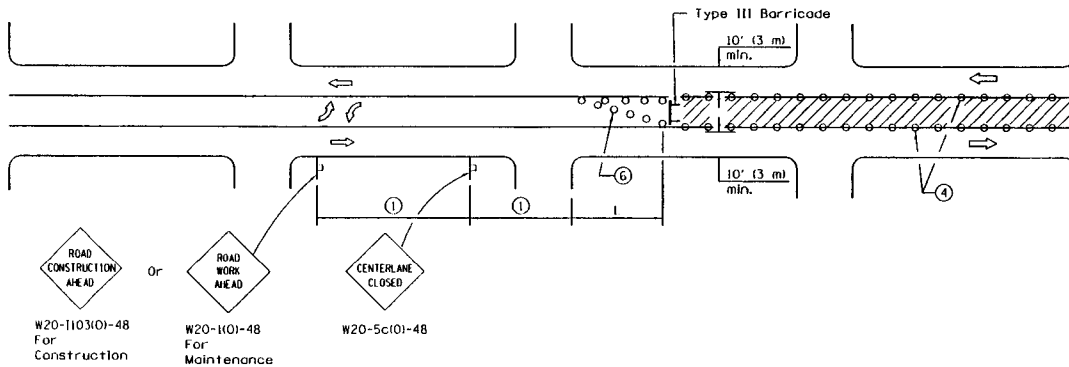

CASE I
(Signs required for both directions)

SIGN SPACING	
Posted Speed	Sign Spacing
55	500' (150 m)
50-45	350' (100 m)
<45	200' (60 m)

- SYMBOLS**
- Work area
 - ϕ Barricade or drum with flashing light
 - Flagger with traffic control sign
 - Cone, drum or barricade (Cones for daytime use only)
 - 3 Sign on portable or permanent support

- ① Refer to SIGN SPACING TABLE for distances.
- ② Required for speeds > 40 mph (70 km/h).
- ③ Required if work exceeds 500' (164 m) or 1 block.
- ④ Cones at 25' (8 m) centers for 250' (75 m). Additional cones may be placed at 15 m (50') centers. When drums or type I or II barricades are used, the interval between devices may be doubled.
- ⑤ For approved sideroad closures.
- ⑥ Cones, drums or barricades at 20' (6 m) centers in taper.
- ⑦ Use flagger sign only when flagger is present.

GENERAL NOTES

This Standard is used to close one lane of an urban, two lane, two way roadway with a bidirectional turn lane.

Case I applies when no workers are present. When workers are present, two lanes shall be closed and traffic control shall be according to Standard 701501.

Calculate L as follows:

SPEED LIMIT	FORMULAS	
	English	(Metric)
40 mph (70 km/h) or less:	$L = \frac{WS^2}{60}$	$L = \frac{WS^2}{150}$
45 mph (80 km/h) or greater:	$L = (W)(S)$	$L = 0.65(W)(S)$

W = Width of offset
In feet (meters).

S = Normal posted speed
mph (km/h).

All dimensions are in inches (millimeters) unless otherwise shown.

Illinois Department of Transportation

APPROVED: *[Signature]* JANUARY 1, 2014
ENGINEER OF SAFETY ENGINEERING

APPROVED: *[Signature]* JANUARY 1, 2014
ENGINEER OF DESIGN AND ENVIRONMENT

10-1-1 (08/95)

DATE	REVISIONS
1-1-14	Omitted original note ④. Rev. workers sign no. to agree with current MUTCD.
1-1-13	Omitted text 'WORKERS' sign.

**URBAN LANE CLOSURE,
2L, 2W, WITH BIDIRECTIONAL
LEFT TURN LANE**
(Sheet 1 of 2)

STANDARD 701502-06

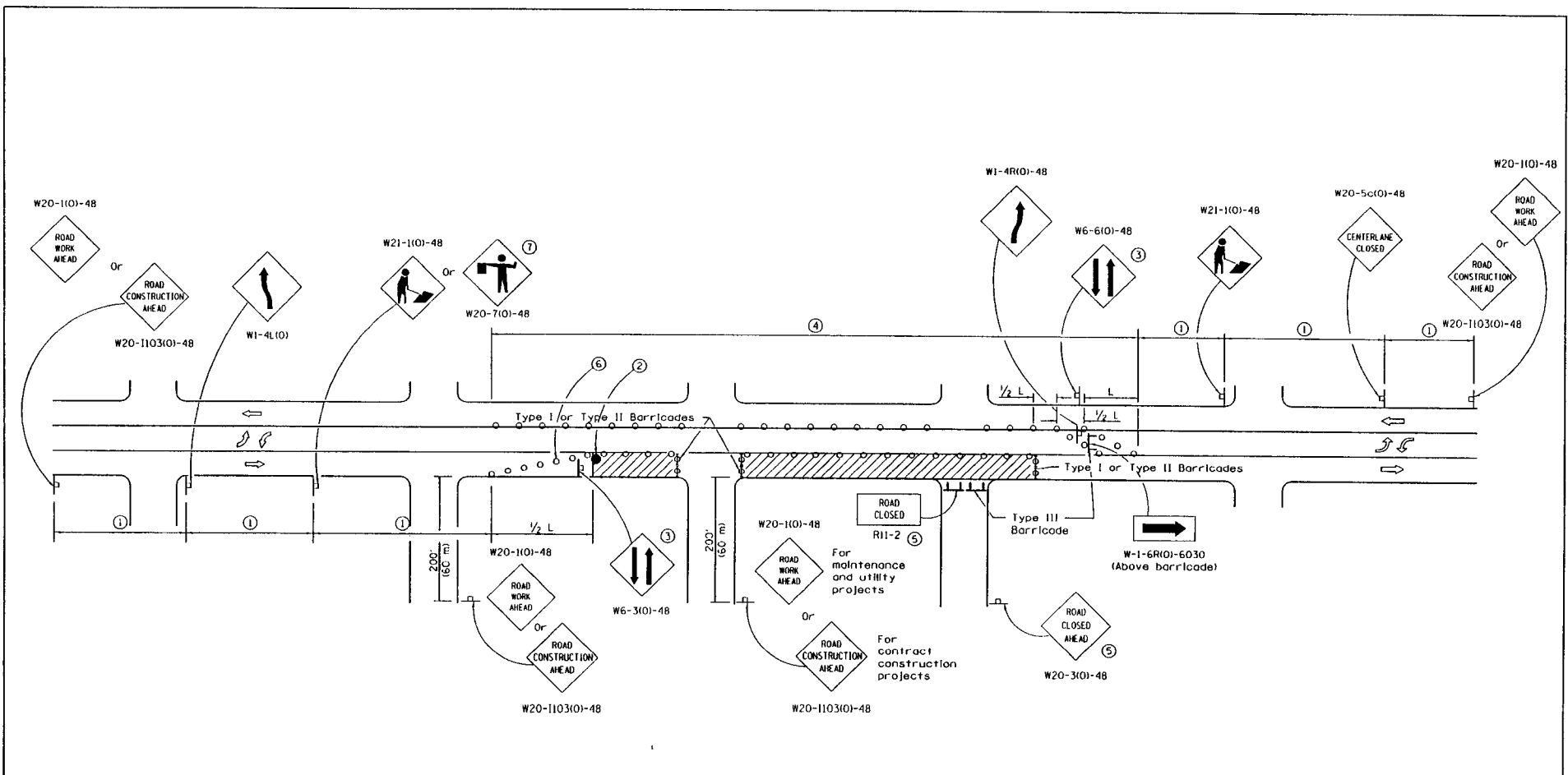

CASE II

Illinois Department of Transportation

APPROVED January 1, 2014
 ENGINEER OF SAFETY ENGINEERING

APPROVED January 1, 2014
 ENGINEER OF DESIGN AND ENVIRONMENT

10-1-1 02/05/11

**URBAN LANE CLOSURE,
 2L, 2W, WITH BIDIRECTIONAL
 LEFT TURN LANE**
 (Sheet 2 of 2)

STANDARD 701502-06

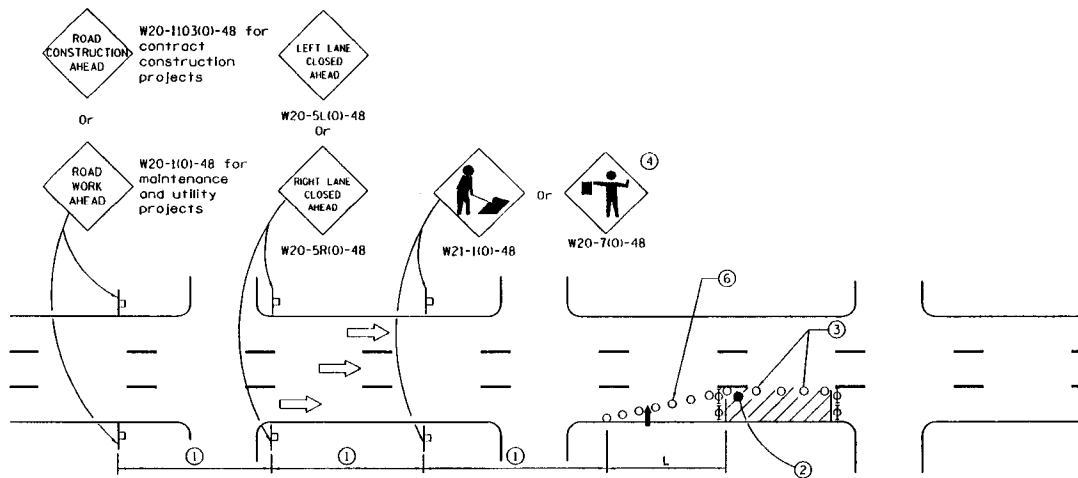

SIGN SPACING	
Posted Speed	Sign Spacing
55	500' (150 m)
50-45	350' (100 m)
<45	200' (60 m)

SYMBOLS

- Arrow board
- Cone, drum or barricade
- Sign on portable or permanent support
- Work area
- Barricade or drum with flashing light
- Type III barricade with flashing lights
- Flagger with traffic control sign.

- ① Refer to SIGN SPACING TABLE for distances.
- ② Required for speeds > 40 MPH
- ③ Cones at 25' (8 m) centers for 250' (75 m). Additional cones may be placed at 50' (15 m) centers. When drums or Type I or Type II barricades are used, the interval between devices may be doubled.
- ④ Use flagger sign only when flagger is present.
- ⑤ For approved slideroad closures.
- ⑥ Cones, drums or barricades at 20' (6 m) in taper.

GENERAL NOTES

This Standard is used where at any time, day or night, any vehicle, equipment, workers or their activities encroach on the pavement during shoulder operations or where construction requires lane closures in urban areas.

Calculate L as follows:

SPEED LIMIT	FORMULAS	
	English	(Metric)
40 mph (70 km/h) or less:	$L = \frac{WS^2}{60}$	$L = \frac{WS^2}{150}$
45 mph (80 km/h) or greater:	$L = (WS)$	$L = 0.65(WS)$

W = Width of offset in feet (meters).
 S = Normal posted speed mph (km/h).

All dimensions are in inches (millimeters) unless otherwise shown.

Illinois Department of Transportation

APPROVED January 1, 2014
 ENGINEER OF SAFETY ENGINEERING

APPROVED January 1, 2014
 ENGINEER OF DESIGN AND ENVIRONMENT

ISSUED 1-1-14

DATE	REVISIONS
1-1-14	Revised workers sign number to agree with current MUTCD.
1-1-13	Omitted text 'WORKERS' sign.

URBAN LANE CLOSURE, MULTILANE, 1W OR 2W WITH NONTRAVERSABLE MEDIAN
 (Sheet 1 of 2)

STANDARD 701601-09

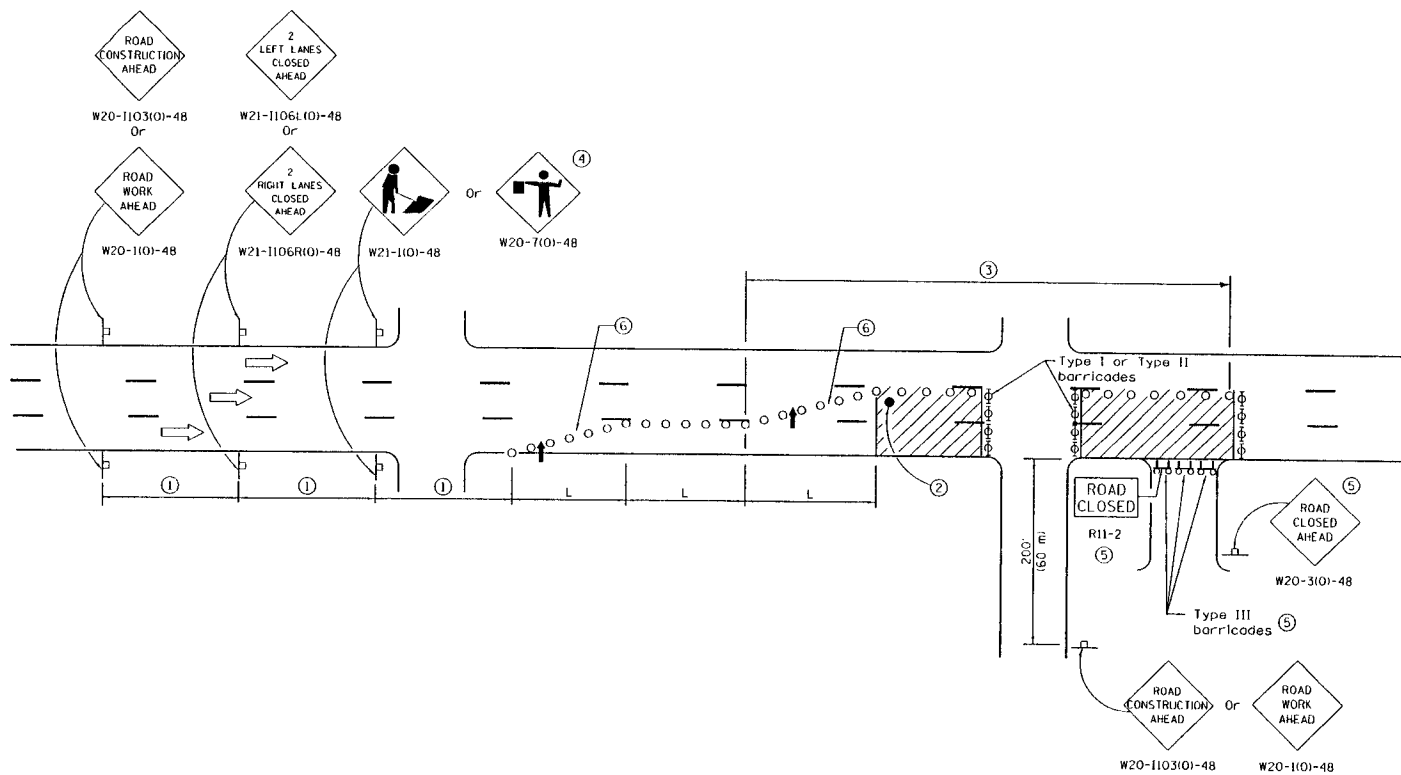

Illinois Department of Transportation

APPROVED January 1, 2014
 ENGINEER OF SAFETY ENGINEERING

ISSUED 1-1-97

APPROVED January 1, 2014
 ENGINEER OF DESIGN AND ENVIRONMENT

**URBAN LANE CLOSURE,
 MULTILANE, 1W OR 2W WITH
 NONTRAVERSABLE MEDIAN**
 (Sheet 2 of 2)

STANDARD 701601-09

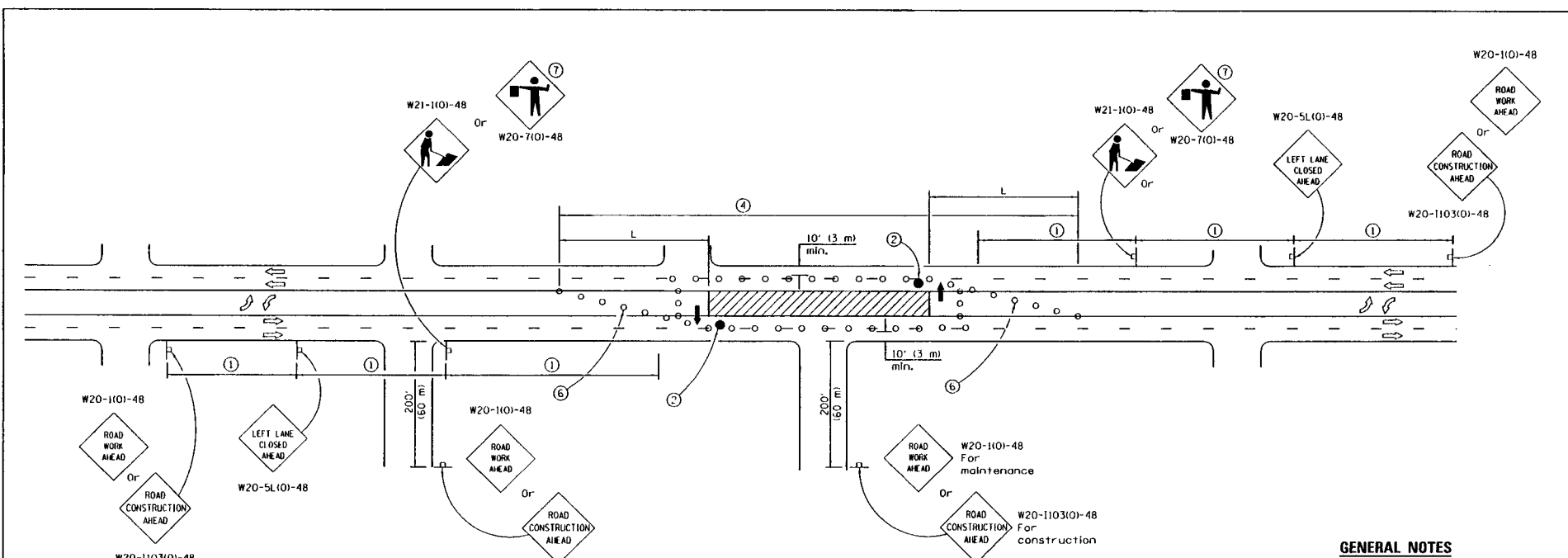

SIGN SPACING	
Posted Speed	Sign Spacing
55	500' (150 m)
50-45	350' (110 m)
<45	200' (60 m)

- SYMBOLS**
- ↑ Arrow board
 - ▨ Work area
 - ⊕ Barricade or drum with steady burning nondirectional light
 - Flogger with traffic control sign
 - Cone, drum or barricade (Cones for daytime use only)
 - ⊥ Sign on portable or permanent support
 - ⌈ Type III Barricade

CASE I

- ① Refer to SIGN SPACING TABLE for distances.
- ② Required for speeds > 40 mph (70 km/h).
- ③ Required if work exceeds 500' (164 m) or 1 block, repeat every 1 mile (1.6 km).
- ④ Cones at 25' (8 m) centers for 250' (75 m). Additional cones may be placed at 50' (15 m) centers. When drums or type I or II barricades are used, the interval between devices may be doubled.
- ⑤ For approved sideroad closures.
- ⑥ Cones, drums or barricades at 20' (6 m) centers in taper.
- ⑦ Use flogger sign only when flogger is present.

GENERAL NOTES

This Standard is used where at any time, day or night, any vehicle, equipment, workers or their activities encroach on the pavement requiring the closure of one traffic lane in an Urban area.

If the work operation is performed between 9:00 a.m. and 3:00 p.m. and does not exceed 15 min. Traffic protection shall be as shown for Standard 701426.

Calculate L as follows:

SPEED LIMIT	FORMULAS	
	English	(Metric)
40 mph (70 km/h) or less:	$L = \frac{WS^2}{60}$	$L = \frac{WS^2}{150}$
45 mph (80 km/h) or greater:	$L = (W)(S)$	$L = 0.65(W)(S)$

W = Width of offset in feet (meters).

S = Normal posted speed mph (km/h).

All dimensions are in inches (millimeters) unless otherwise shown.

Illinois Department of Transportation

APPROVED: January 1, 2014
 ENGINEER OF SAFETY ENGINEERING

APPROVED: January 1, 2014
 ENGINEER OF DESIGN AND ENVIRONMENT

DATE	REVISIONS
1-1-14	Omitted original note ④.
	Rev. workers sign no. to agree with current MUTCD.
1-1-13	Omitted text 'WORKERS'
	sign.

URBAN LANE CLOSURE, MULTILANE, 2W WITH BIDIRECTIONAL LEFT TURN LANE
 (Sheet 1 of 4)

STANDARD 701602-07

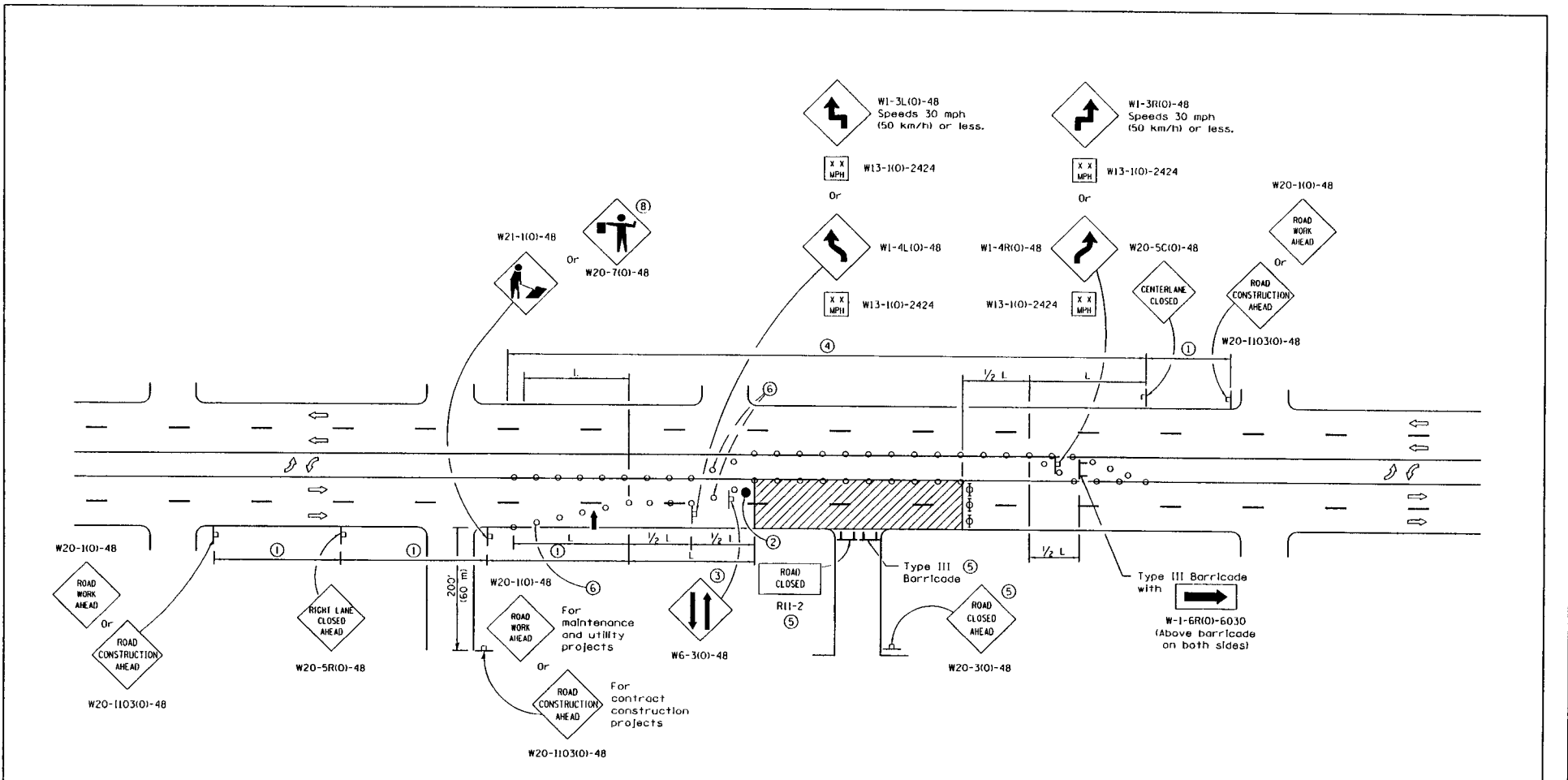

CASE II

Illinois Department of Transportation

APPROVED January 1, 2014
[Signature]
 ENGINEER OF SAFETY ENGINEERING

ISSUED 10-1-10-10

APPROVED January 1, 2014
[Signature]
 ENGINEER OF DESIGN AND ENVIRONMENT

**URBAN LANE CLOSURE,
 MULTILANE, 2W WITH
 BIDIRECTIONAL LEFT TURN LANE**
 (Sheet 2 of 4)

STANDARD 701602-07

STANDARD 70160Z-07
 (Sheet 3 of 4)
**BIDIRECTIONAL LEFT TURN LANE
 MULTILANE, 2W WITH
 URBAN LANE CLOSURE,**

Illinois Department of Transportation
 APPROVED: [Signature] 2014
 ENGINEER OF SAFETY ENGINEERING
 APPROVED: [Signature] 2014
 ENGINEER OF HIGHWAY AND ENVIRONMENT
 10-1-1 CANS51

CASE III

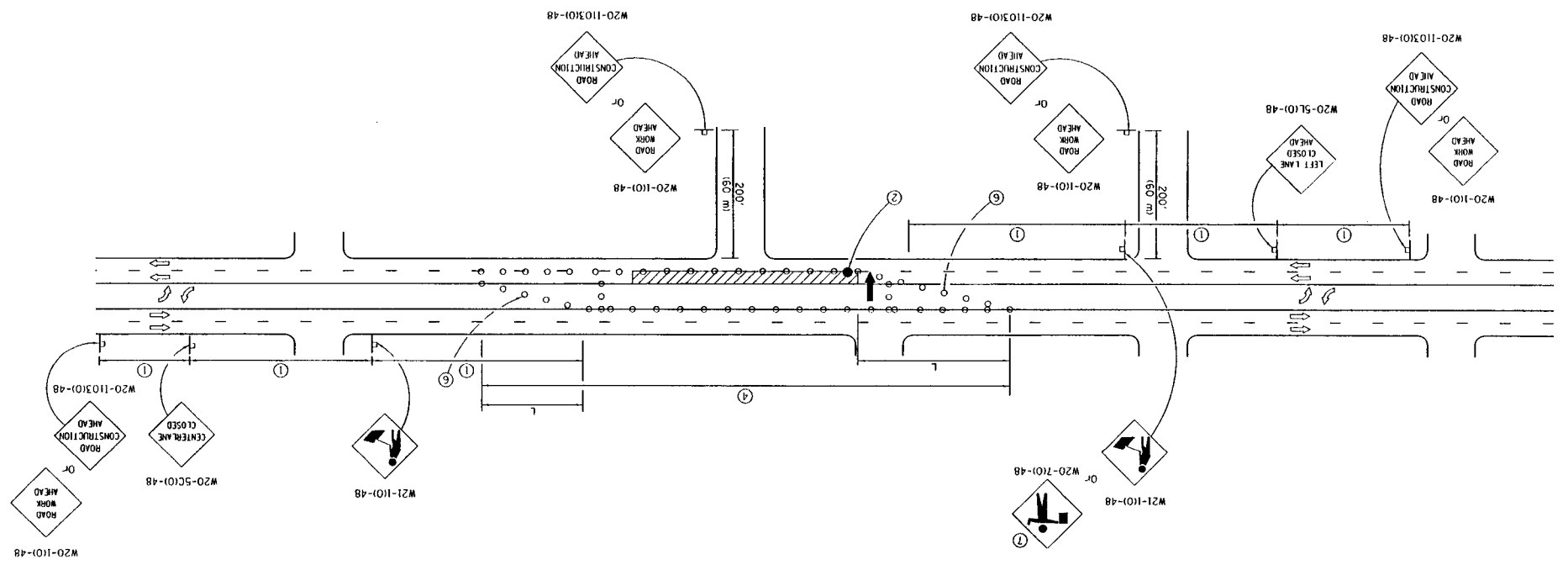

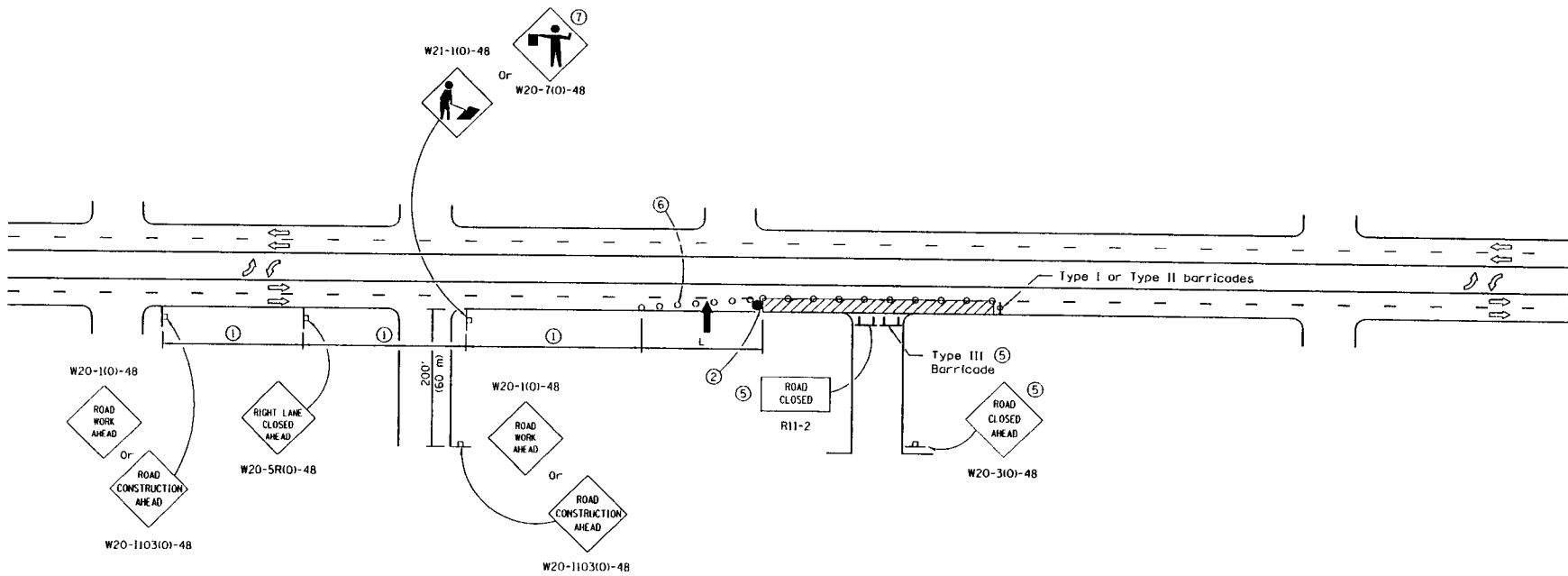

CASE IV

Illinois Department of Transportation

APPROVER	January 1, 2014	13
ENGINEER OF SAFETY ENGINEERING		
APPROVED	January 1, 2014	
ENGINEER OF DESIGN AND ENVIRONMENT		

**URBAN LANE CLOSURE,
MULTILANE, 2W WITH
BIDIRECTIONAL LEFT TURN LANE**
(Sheet 4 of 4)

STANDARD 701602-07

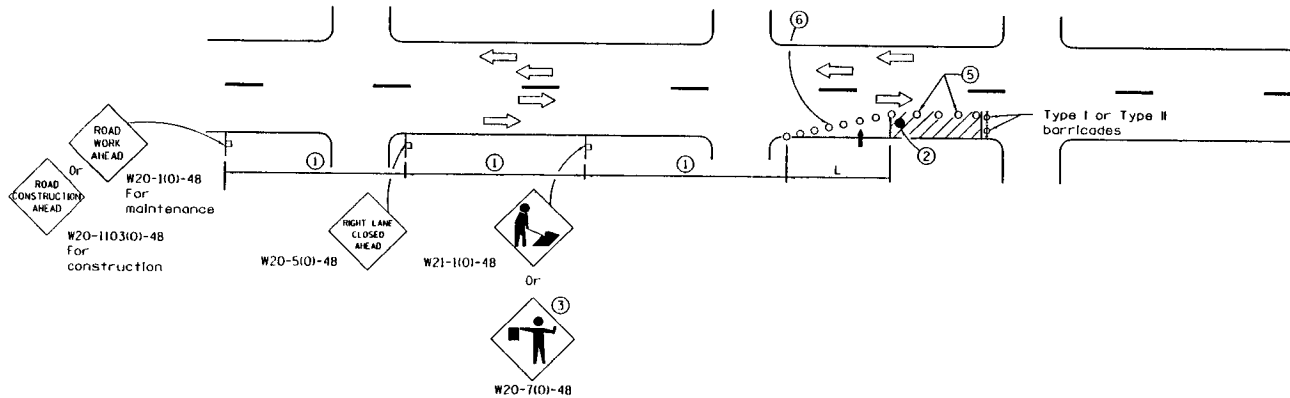

SIGN SPACING	
Posted Speed	Sign Spacing
55	500' (150 m)
50-45	350' (100 m)
<45	200' (60 m)

SYMBOLS

- ↑ Arrow board
- Cone, drum or barricade
- ⊥ Sign on portable or permanent support
- ▨ Work area
- ⊕ Barricade or drum with flashing light
- ⊥ Type III barricade with flashing lights
- Flagger with traffic control sign.

- ① Refer to SIGN SPACING TABLE for distances.
- ② Required for speeds > 40 mph.
- ③ Use flagger sign only when flagger is present.
- ④ For approved slideroad closures.
- ⑤ Cones at 25' (8 m) centers for 250' (75 m). Additional cones may be placed at 50' (15 m) centers. When drums or Type I or Type II barricades are used, the interval between devices may be doubled.
- ⑥ Cones, drums or barricades at 20' (6 m) centers in taper.
- ⑦ Repeat every 1 mile (1.6 km).

GENERAL NOTES

This Standard is used where at any time, day or night, any vehicle, equipment, workers or their activities encroach on the pavement requiring the closure of one or more traffic lanes in an Urban area.

Calculate L as follows:

SPEED LIMIT

FORMULAS

40 mph (70 km/h) or less:

$$L = \frac{WS^2}{60} \quad L = \frac{WS^2}{150}$$

45 mph (80 km/h) or greater:

$$L = (W)(S) \quad L = 0.65(W)(S)$$

W = Width of offset in feet (meters).

S = Normal posted speed mph (km/h).

All dimensions are in inches (millimeters) unless otherwise shown.

Illinois Department of Transportation

APPROVED January 1, 2014
James Allen
 ENGINEER OF SAFETY ENGINEERING

APPROVED January 1, 2014
[Signature]
 ENGINEER OF DESIGN AND ENVIRONMENT

46-1-1-02(153)

DATE	REVISIONS
1-1-14	Revised workers sign number to agree with current MUTCD.
1-1-12	Corrected dimension in note (6). Omitted W21-1110 sign. Added W-1-6R sign.

URBAN LANE CLOSURE, MULTILANE, 2W WITH MOUNTABLE MEDIAN
 (Sheet 1 of 2)

STANDARD 701606-09

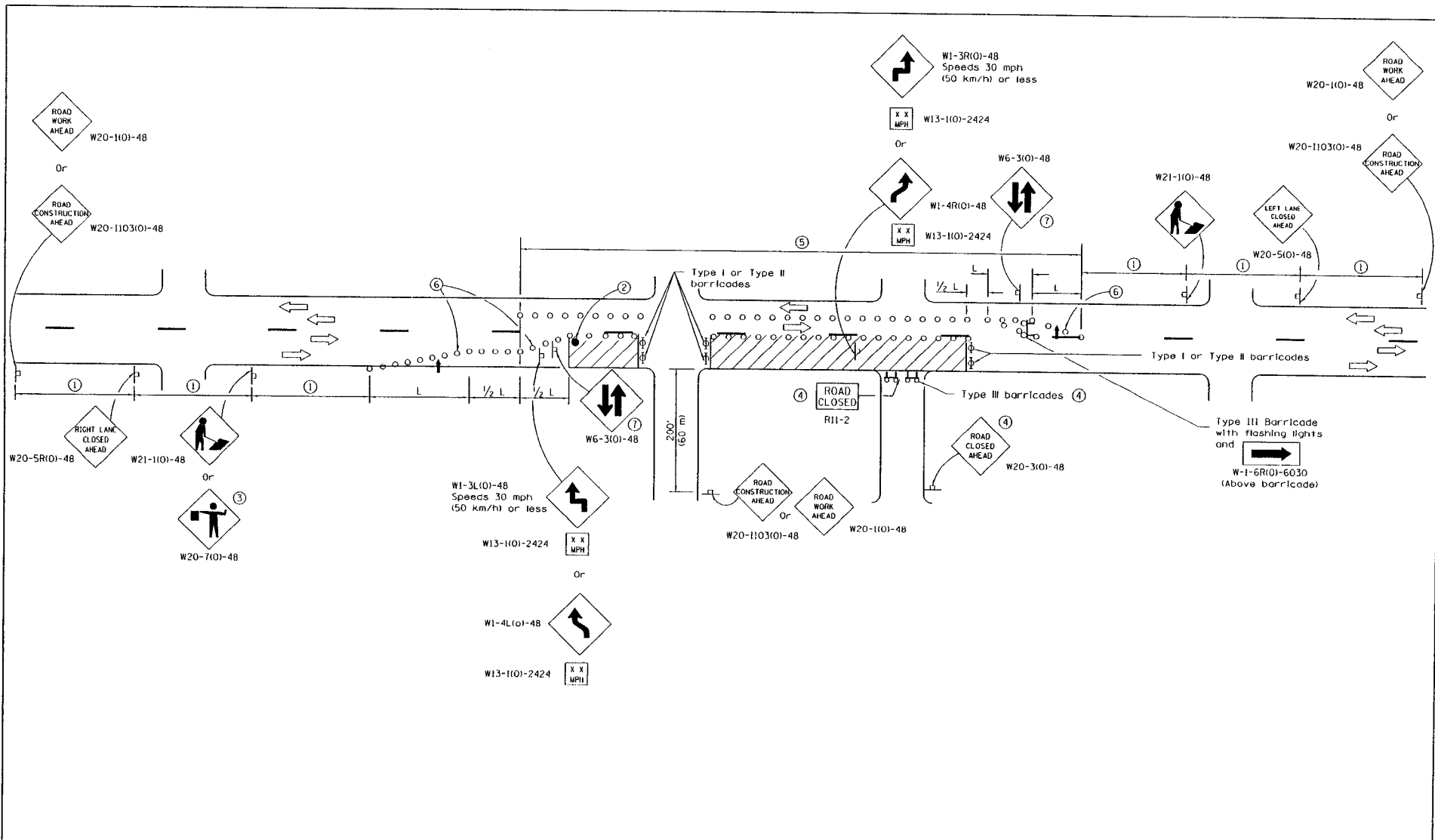

 Illinois Department of Transportation
 APPROVED: January 1, 2014
James A. [Signature]
 ENGINEER OF SAFETY ENGINEERING
 APPROVED: January 1, 2014
[Signature]
 ENGINEER OF DESIGN AND ENVIRONMENT

**URBAN LANE CLOSURE,
 MULTILANE, 2W WITH
 MOUNTABLE MEDIAN**
 (Sheet 2 of 2)

STANDARD 701686-09

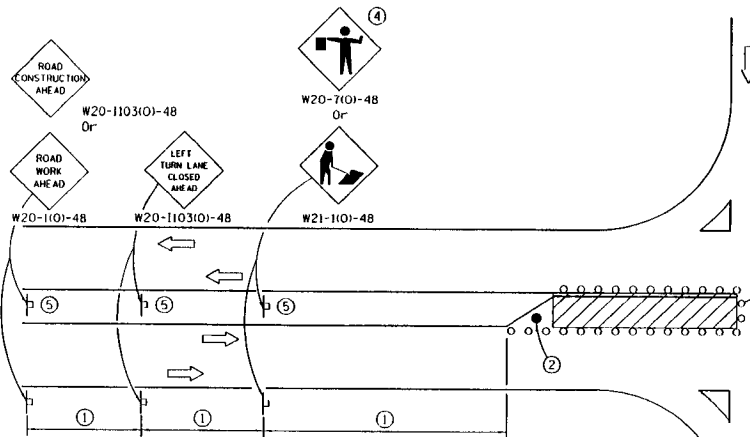

**LEFT TURN LANE OR CENTER
MEDIAN OPERATIONS**

- ① Refer to SIGN SPACING TABLE for distance.
- ② Required for speed > 40 mph.
- ③ Cones at 25' (8 m) centers for 250' (75 m). Additional cones may be placed at 50' (15 m) centers. When drums or Type I or Type II barricades are used, the interval between devices may be doubled.
- ④ Use flagger sign only when flagger is present.
- ⑤ Omit this sign when median is less than 10' (3 m) or for bi-directional turn lanes.
- ⑥ Cones, drums or barricades at 20' (6 m) centers in taper.
- ⑦ Advanced arrow board required for speeds > 45 mph.
- ⑧ Three Type II barricades, drums or vertical barricades at 50' (15 m) centers.

SIGN SPACING	
Posted Speed	Sign Spacing
55	500' (150 m)
50-45	350' (100 m)
<45	200' (60 m)

SYMBOLS

- Work area
- Cone, drum or barricade
- Sign on portable or permanent support
- Arrow board
- Barricade or drum with flashing light
- Flagger with traffic control sign

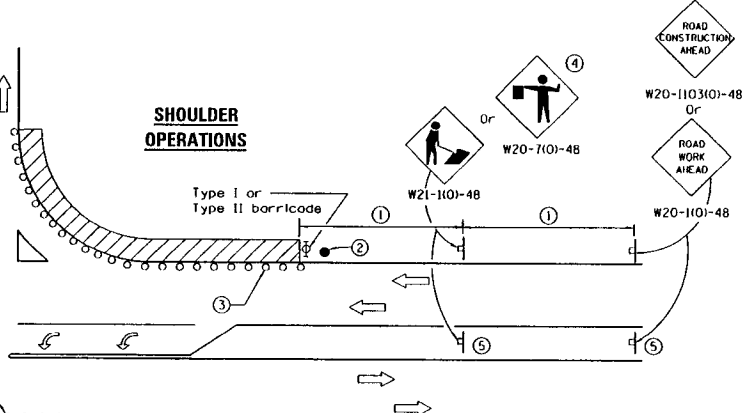

**SHOULDER
OPERATIONS**

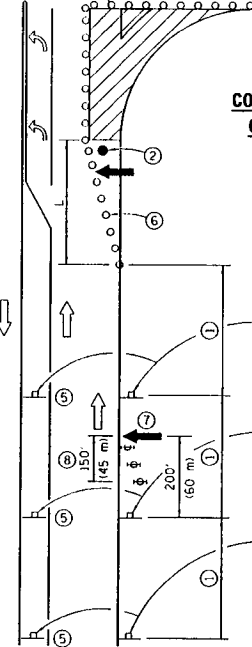

**CORNER ISLAND
OPERATIONS**

GENERAL NOTES

This Standard is used where at any time, day or night, any vehicle, equipment, workers or their activities encroach on the pavement during shoulder operations or where construction requires lane closures in an urban area.

Calculate L as follows:

SPEED LIMIT

40 mph (70 km/h) or less:
45 mph (80 km/h) or greater:

FORMULAS

English (Metric)

$$L = \frac{WS^2}{60} \quad L = \frac{WS^2}{150}$$

$$L = (WHS) \quad L = 0.65(WHS)$$

W = Width of offset in feet (meters).
S = Normal posted speed mph (km/h).

All dimensions are in inches (millimeters) unless otherwise shown.

Illinois Department of Transportation

APPROVED: January 1, 2014
 ENGINEER OF SAFETY ENGINEERING

ISSUED: 1-1-97

APPROVED: January 1, 2014
 ENGINEER OF DESIGN AND ENVIRONMENT

DATE	REVISIONS
1-1-14	Added devices at arrow board upstream from taper.
	Rev. workers sign number.
1-1-12	Revised flagger sign.
	Omitted W21-1110 sign.

**URBAN LANE CLOSURE,
MULTILANE INTERSECTION**

STANDARD 701701-09

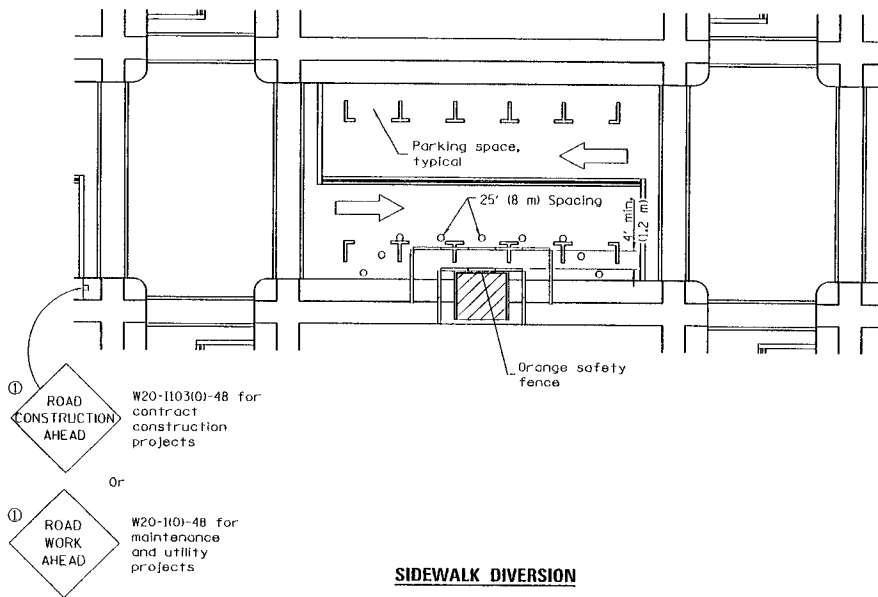

① Omit whenever duplicated by road work traffic control.

SYMBOLS

- Work area
- Sign on portable or permanent support
- Barricade or drum
- Cone, drum or barricade
- Type III barricade
- Detectable pedestrian channelizing barricade

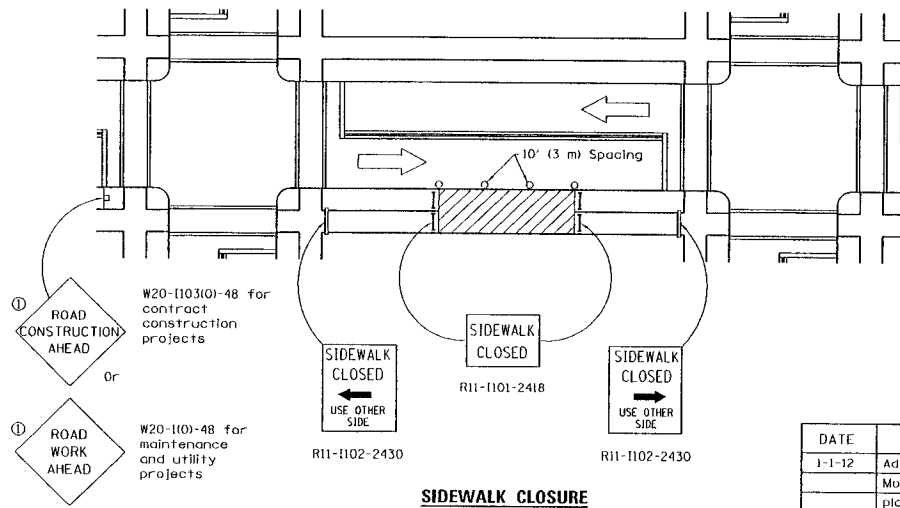

GENERAL NOTES

This Standard is used where, at any time, pedestrian traffic must be rerouted due to work being performed.

This Standard must be used in conjunction with other Traffic Control & Protection Standards when roadway traffic is affected.

Temporary facilities shall be detectable and accessible.

The temporary pedestrian facilities shall be provided on the same side of the closed facilities whenever possible.

The SIDEWALK CLOSED / USE OTHER SIDE sign shall be placed at the nearest crosswalk or intersection to each end of the closure. Where the closure occurs at a corner, the signs shall be erected on the corners across the street from the closure. The SIDEWALK CLOSED signs shall be used at the ends of the actual closures.

Type III barricades and R11-2-4830 signs shall be positioned as shown in "ROAD CLOSED TO ALL TRAFFIC" detail on Standard 701901.

All dimensions are in Inches (millimeters) unless otherwise shown.

Illinois Department of Transportation

APPROVER January 1, 2012
Richard C. [Signature]
 ENGINEER OF SAFETY ENGINEERING

APPROVED January 1, 2012
[Signature]
 ENGINEER OF DESIGN AND ENVIRONMENT

16-1.1 (REVISED)

DATE	REVISIONS
1-1-12	Added SIDEWALK DIVERSION.
	Modified appearance of plan views. Renamed Std.
1-1-09	Switched units to English (metric), 702001 to 701901.

SIDEWALK, CORNER OR CROSSWALK CLOSURE

(Sheet 1 of 2)

STANDARD 701801-05

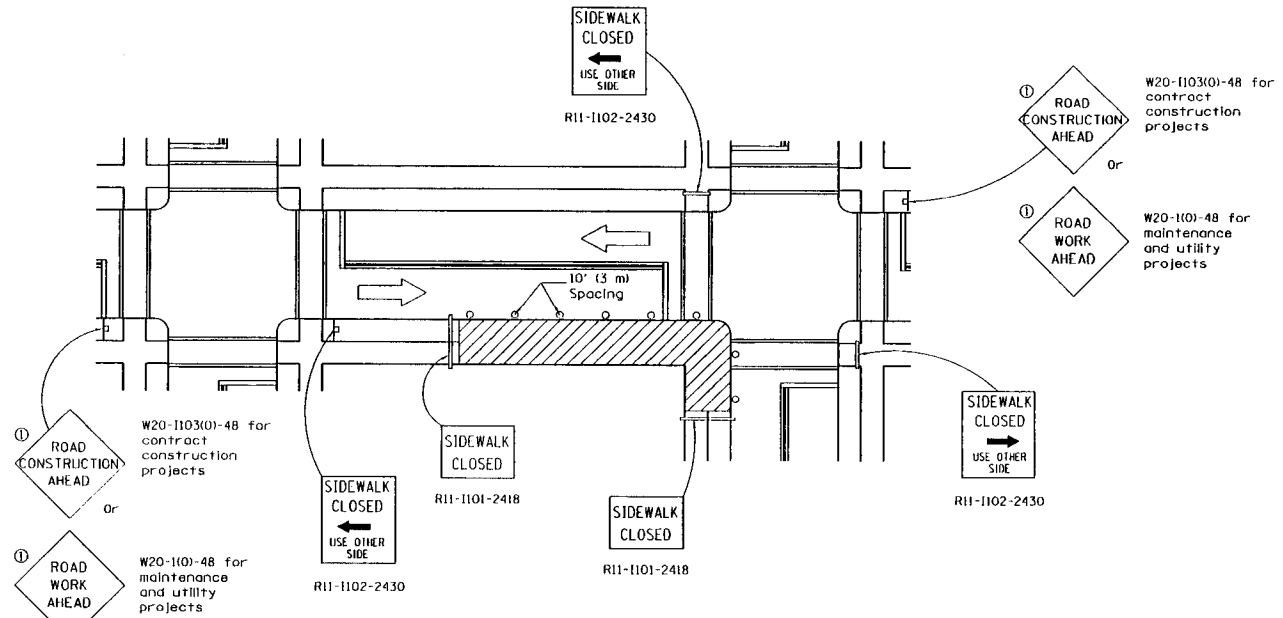

CORNER CLOSURE

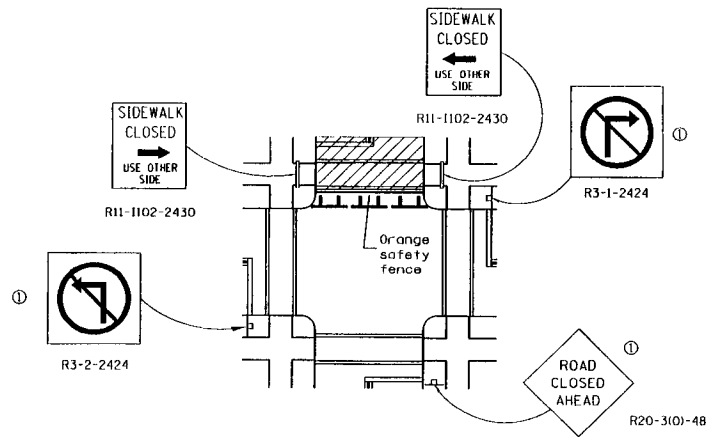

CROSSWALK CLOSURE

SIDEWALK, CORNER OR CROSSWALK CLOSURE

(Sheet 2 of 2)

STANDARD 701801-05

Illinois Department of Transportation

APPROVED: *[Signature]* January 1, 2012
 ENGINEER OF SAFETY ENGINEERING

APPROVED: *[Signature]* January 1, 2012
 ENGINEER OF DESIGN AND ENVIRONMENT

ISSUED: 1-1-97

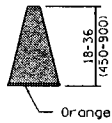

CONE

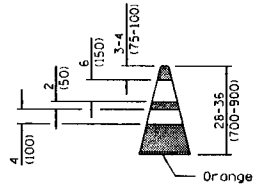

REFLECTORIZED CONE

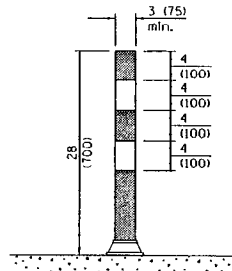

FLEXIBLE DELINEATOR

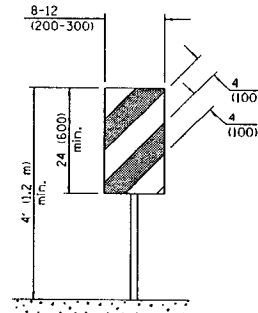

**VERTICAL PANEL
POST MOUNTED**

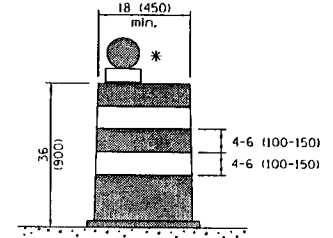

DRUM

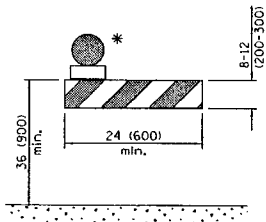

TYPE I BARRICADE

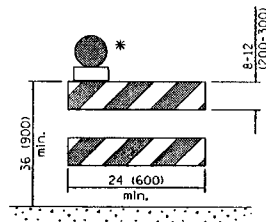

TYPE II BARRICADE

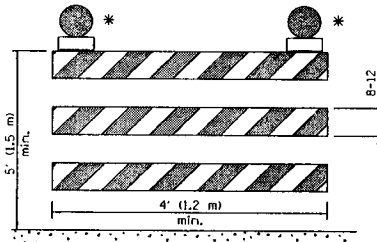

TYPE III BARRICADE

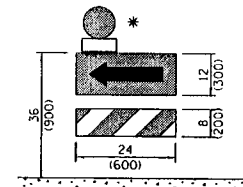

**DIRECTION INDICATOR
BARRICADE**

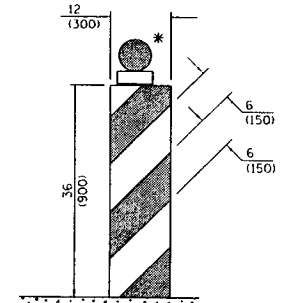

VERTICAL BARRICADE

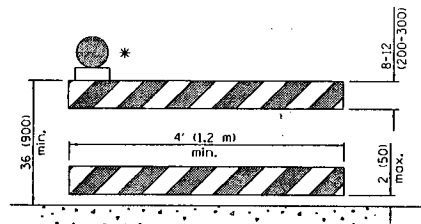

**DETECTABLE PEDESTRIAN
CHANNELIZING BARRICADE**

* Warning lights (if required)

Illinois Department of Transportation	
APPROVED	JANUARY 1, 2014
ENGINEER/OF OPERATIONS	<i>Jason Mann</i>
APPROVED	JANUARY 1, 2014
ENGINEER OF DESIGN AND ENVIRONMENT	<i>[Signature]</i>
46-1-1	CRISSE

DATE	REVISIONS
1-1-14	Modified flagger sign height. Added highway construction speed zone signs.
1-1-12	Added DETECTABLE PEDESTRIAN CHANNELIZING BARRICADE.

GENERAL NOTES
All heights shown shall be measured above the pavement surface.

All dimensions are in inches (millimeters) unless otherwise shown.

**TRAFFIC CONTROL
DEVICES**

(Sheet 1 of 3)

STANDARD 701901-03

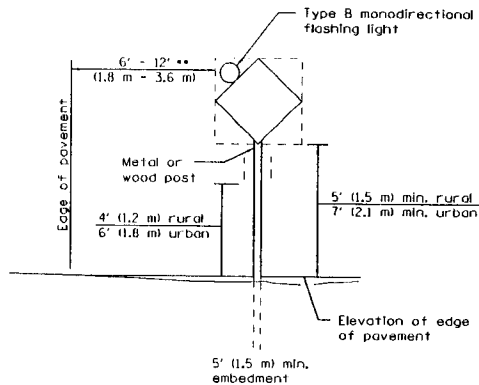

POST MOUNTED SIGNS

** When curb or paved shoulder are present this dimension shall be 24 (600) to the face of curb or 6' (1.8 m) to the outside edge of the paved shoulder.

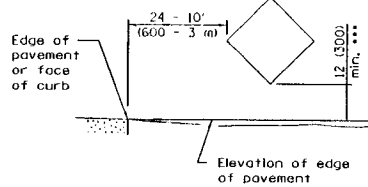

SIGNS ON TEMPORARY SUPPORTS

*** When work operations exceed four days, this dimension shall be 5' (1.5 m) min. If located behind other devices, the height shall be sufficient to be seen completely above the devices.

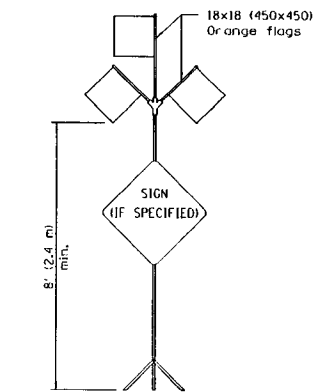

HIGH LEVEL WARNING DEVICE

ROAD CONSTRUCTION NEXT X MILES	END CONSTRUCTION
G20-1101-6036	G20-2a(01)-6024

This signing is required for all projects 2 miles (3200 m) or more in length.

ROAD CONSTRUCTION NEXT X MILES sign shall be placed 500' (150 m) in advance of project limits.

END CONSTRUCTION sign shall be erected at the end of the job unless another job is within 2 miles (3200 m).

Dual sign displays shall be utilized on multi-lane highways.

WORK LIMIT SIGNING

WORK ZONE	W21-1105(0)-3618
SPEED LIMIT XX	R2-1-3648
PHOTO ENFORCED	R10-1108p-3618
\$XXX FINE MINIMUM	R2-1106p-3618

Sign assembly as shown on Standards or as allowed by District Operations.

END WORK ZONE SPEED LIMIT	G20-1103(0)-3660
----------------------------------	------------------

This sign shall be used when the above sign assembly is used.

HIGHWAY CONSTRUCTION SPEED ZONE SIGNS

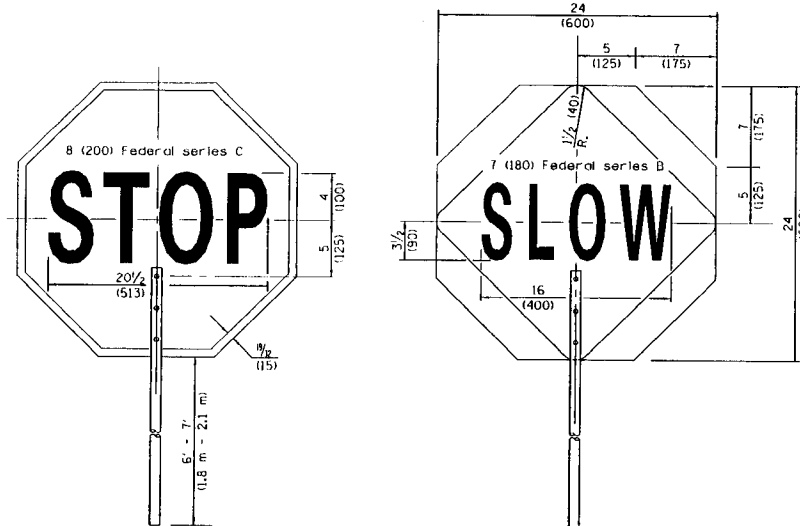

FRONT SIDE

REVERSE SIDE

FLAGGER TRAFFIC CONTROL SIGN

Illinois Department of Transportation

APPROVED	January 1, 2014
<i>[Signature]</i>	
ENGINEER OF OPERATIONS	
APPROVED	January 1, 2014
<i>[Signature]</i>	
ENGINEER OF DESIGN AND ENVIRONMENT	

TRAFFIC CONTROL DEVICES

(Sheet 2 of 3)

STANDARD 701901-03

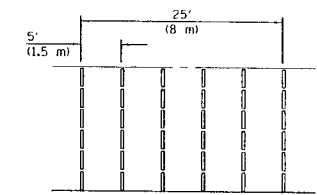
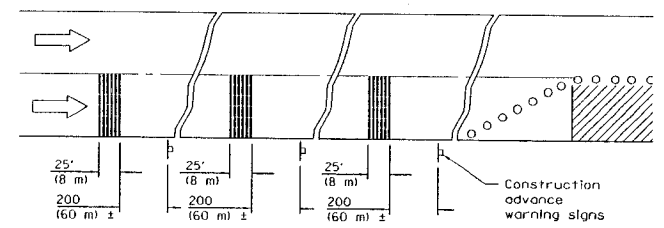
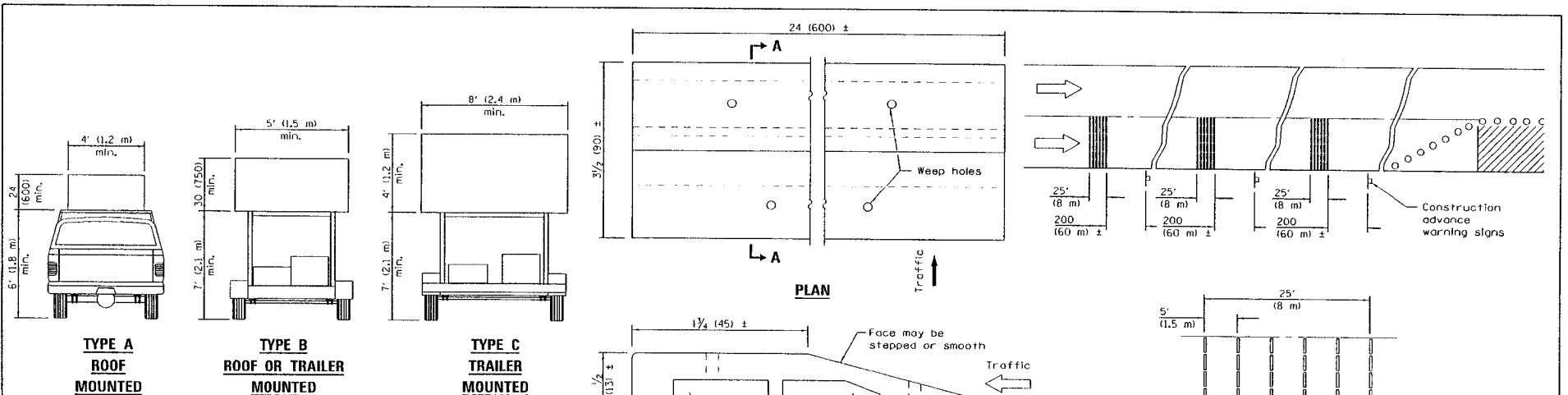

ARROW BOARDS

SECTION A-A

TYPICAL INSTALLATION

TEMPORARY RUMBLE STRIPS

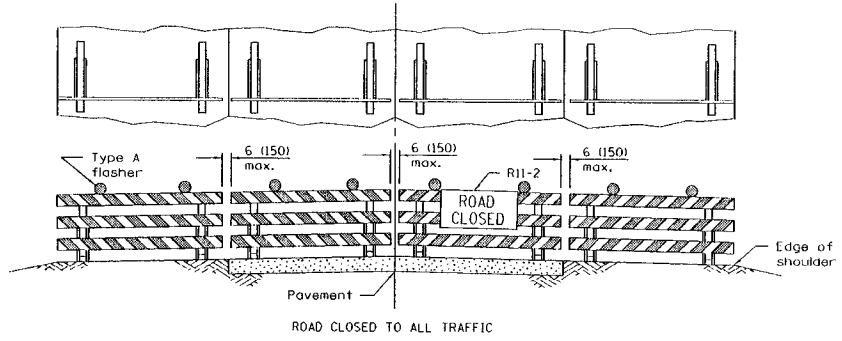

Reflectorized striping may be omitted on the back side of the barricades. If a Type III barricade with an attached sign panel which meets NCHRP 350 is not available, the sign may be mounted on an NCHRP 350 temporary sign support directly in front of the barricade.

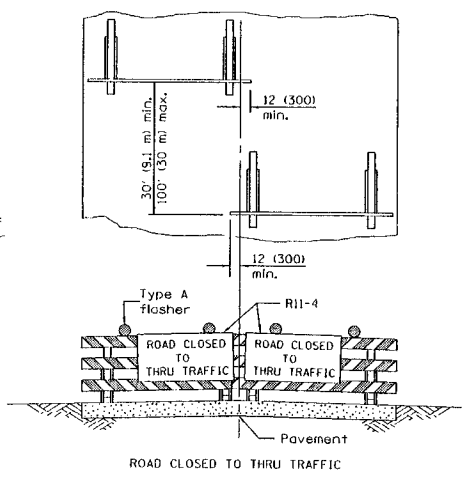

Reflectorized striping shall appear on both sides of the barricades. If a Type III barricade with an attached sign panel which meets NCHRP 350 is not available, the signs may be mounted on NCHRP 350 temporary sign supports directly in front of the barricade.

TYPICAL APPLICATIONS OF TYPE III BARRICADES CLOSING A ROAD

TRAFFIC CONTROL DEVICES
 (Sheet 3 of 3)
STANDARD 701901-03

Illinois Department of Transportation
 APPROVED January 1, 2014
 ENGINEER OF OPERATIONS
 APPROVED January 1, 2014
 ENGINEER OF DESIGN AND ENVIRONMENT

1/2" x 1-1/2" JOINT SHALL BE TOOLED AND SAWED TO A DEPTH OF 1-1/2"

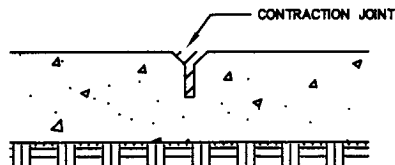

SECTION A-A
CONTRACTION JOINT

1/2" THICK PREFORMED JOINT FILLER SHALL BE INSTALLED 1/2" BELOW SURFACE OF SIDE WALK AND A BEAD OF ONE PART SELF LEVELING URETHANE SEALANT INSTALLED TO LEVEL OF SURFACE.

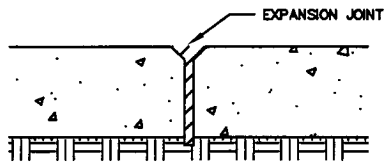

SECTION B-B
EXPANSION JOINT

NOTES:

1. CONTRACTION JOINTS SHALL BE SPACED SO THAT THE DISTANCE TO EXPANSION JOINTS ON EITHER SIDE SHALL NOT EXCEED 20 FEET. MAXIMUM DISTANCE BETWEEN EXPANSION JOINTS SHALL NOT EXCEED 40 FEET.

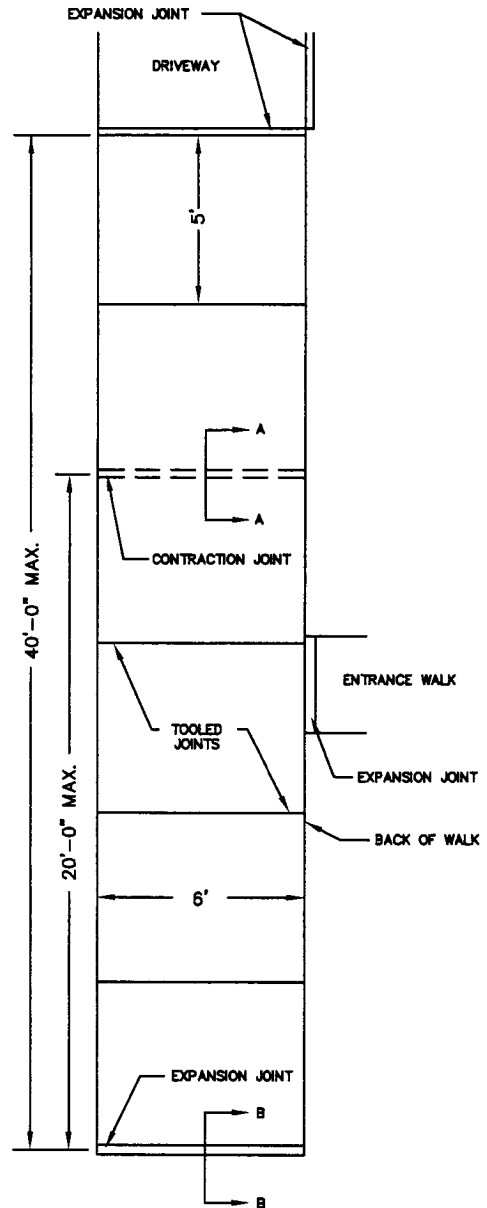

CONTRACTION AND EXPANSION JOINT DETAIL
P.C.C. SIDEWALK, 4"

NOTE:

ALL FOAM/FELT EXPANSION JOINTS SHALL BE CAULKED WITH SELF LEVELING CAULK, COVERING THE SURFACE OF THE JOINT. RUBBERIZED EXPANSION JOINTS ARE NOT REQUIRED TO BE CAULKED.



CITY OF PEORIA
PUBLIC WORKS DEPT. — ENGINEERING DIV.

94

CONTRACTION & EXPANSION JOINTS

DRAWN BY:

BY: SML

DATE:

REVISED: 04/06/16

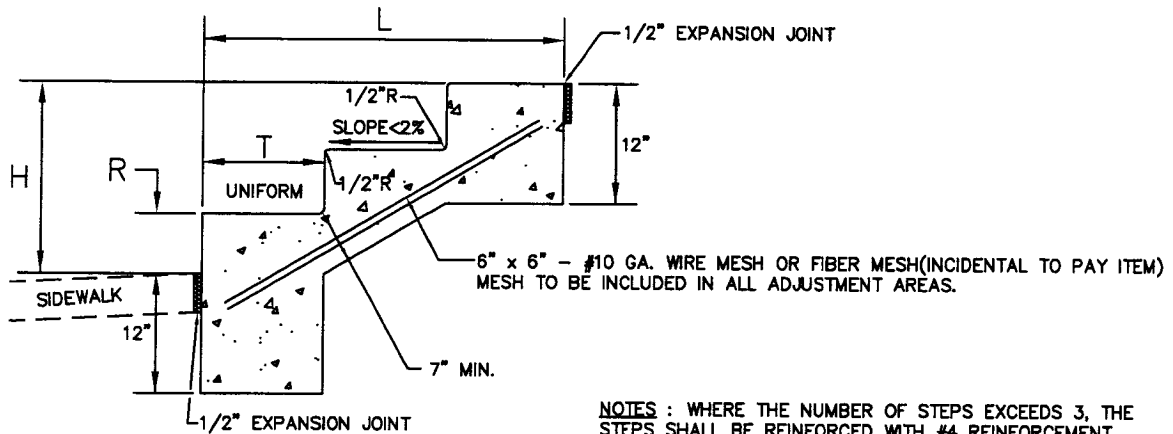

T = TREAD = 12"
 R = RISER = 4" MINIMUM TO 7" MAXIMUM
 ALL RISERS SHALL BE CONSTRUCTED TO EQUAL HEIGHT PER SET OF STEPS.

PAYMENT AREA = (L+H) x WIDTH = SQ. FT.

NOTES : WHERE THE NUMBER OF STEPS EXCEEDS 3, THE STEPS SHALL BE REINFORCED WITH #4 REINFORCEMENT BARS AT SPACINGS NOT TO EXCEED 12" COMMENCING 3" FROM THE SIDES OF THE STEPS IN ADDITION TO THE WIRE MESH REINFORCEMENT INDICATED.

THE TREADS SHALL BE FINISHED WITH A ROUGHER BROOM FINISH THAN SIDEWALKS OR DRIVEWAYS

HANDRAIL SHALL BE INSTALLED AT ITS SEPARATE UNIT PRICE FOR AREAS DETERMINED TO NEED HANDRAIL

NOTE:
 ALL FOAM/FELT EXPANSION JOINTS SHALL BE CAULKED WITH SELF LEVELING CAULK, COVERING THE SURFACE OF THE JOINT.
 RUBBERIZED EXPANSION JOINTS ARE NOT REQUIRED TO BE CAULKED.



CITY OF PEORIA

PUBLIC WORKS DEPT. — ENGINEERING DIV.

P.C.C. STEPS

DRAWN BY:

BY: SML

DATE:

REVISED: 04/06/16

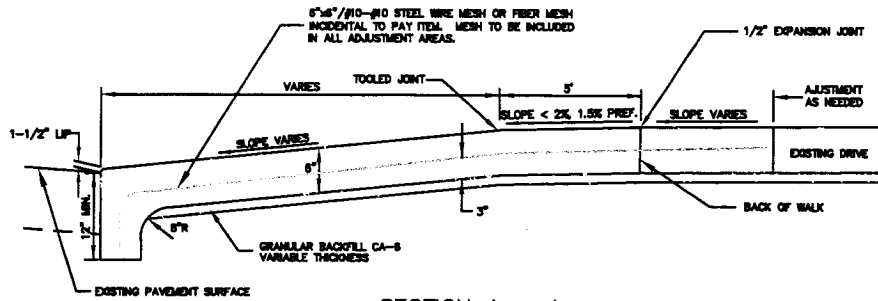

SECTION A - A

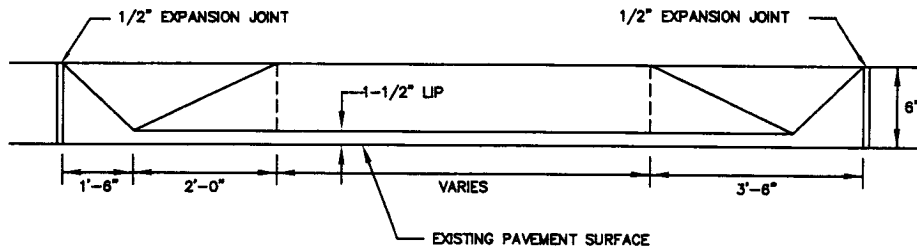

CURB LINE PROFILE

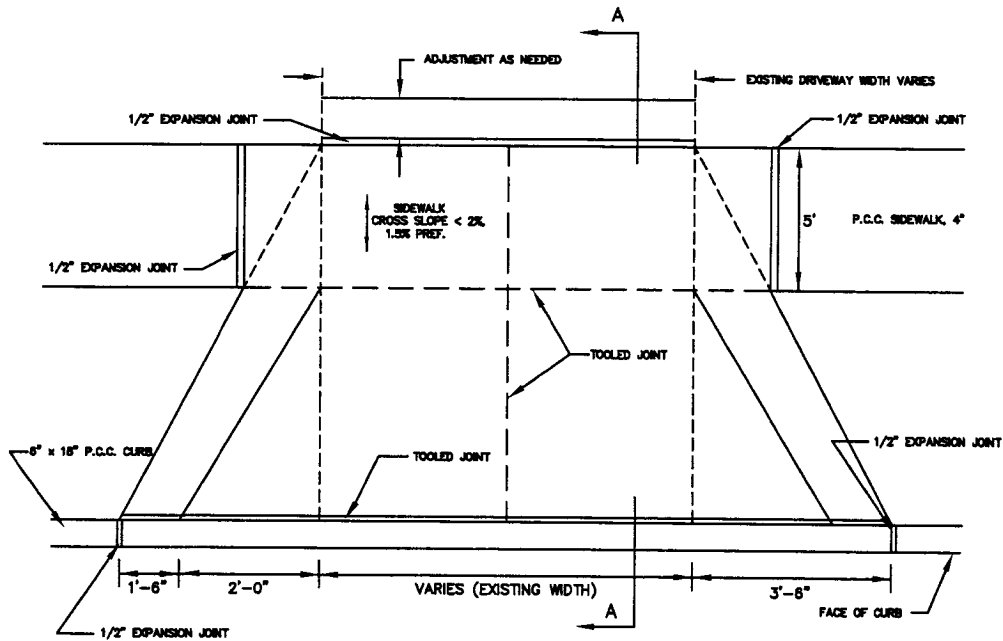

P.C.C. DRIVEWAY PAVEMENT, 6"
ADJACENT TO PROPERTY LINE SIDEWALK

NOTE:
ALL FOAM/FELT EXPANSION JOINTS SHALL BE CAULKED WITH SELF LEVELING CAULK, COVERING THE SURFACE OF THE JOINT.
RUBBERIZED EXPANSION JOINTS ARE NOT REQUIRED TO BE CAULKED.



CITY OF PEORIA
PUBLIC WORKS DEPT. - ENGINEERING DIV.

P.C.C. DRIVEWAY PAVEMENT

DRAWN BY:

BY: SML

DATE:

REVISED: 04/06/16

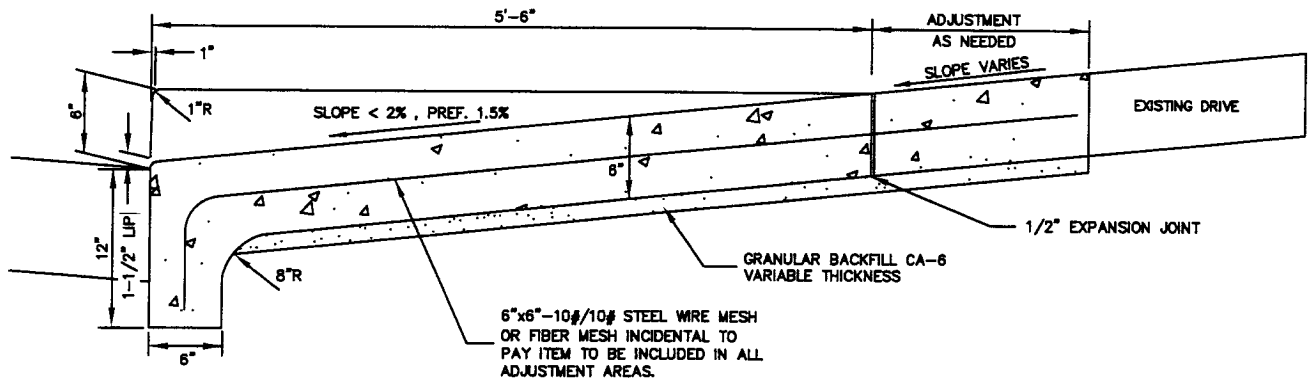

SECTION A - A

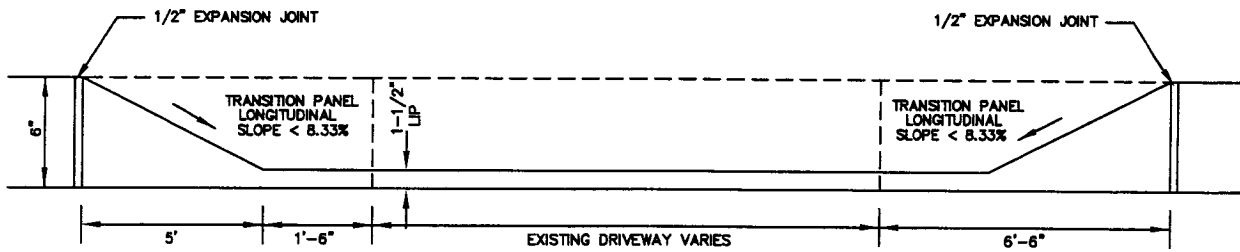

CURB LINE PROFILE

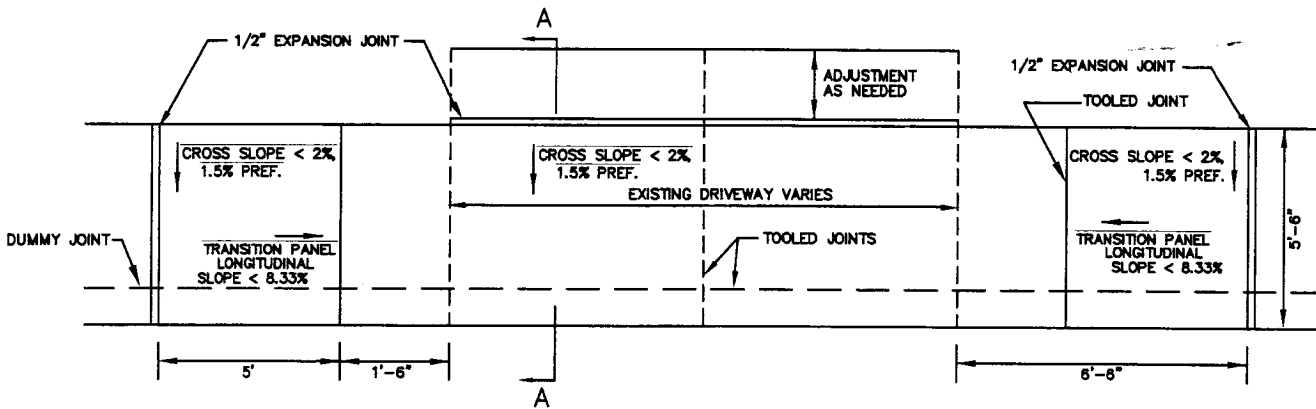

P.C.C. DRIVEWAY PAVEMENT - 6"
ADJACENT TO COMBINATION CURB AND SIDEWALK

NOTE:

ALL FOAM/FELT EXPANSION JOINTS SHALL BE CAULKED WITH SELF LEVELING CAULK, COVERING THE SURFACE OF THE JOINT. RUBBERIZED EXPANSION JOINTS ARE NOT REQUIRED TO BE CAULKED.



CITY OF PEORIA

PUBLIC WORKS DEPT. - ENGINEERING DIV.

P.C.C. DRIVEWAY PAVEMENT

DRAWN BY:

BY: SML

DATE:

REVISED: 04/06/16

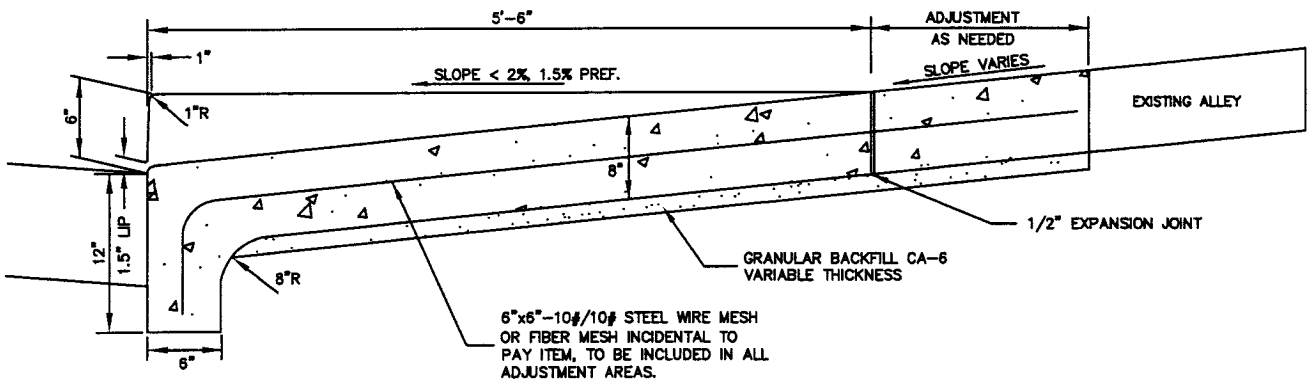

SECTION A - A

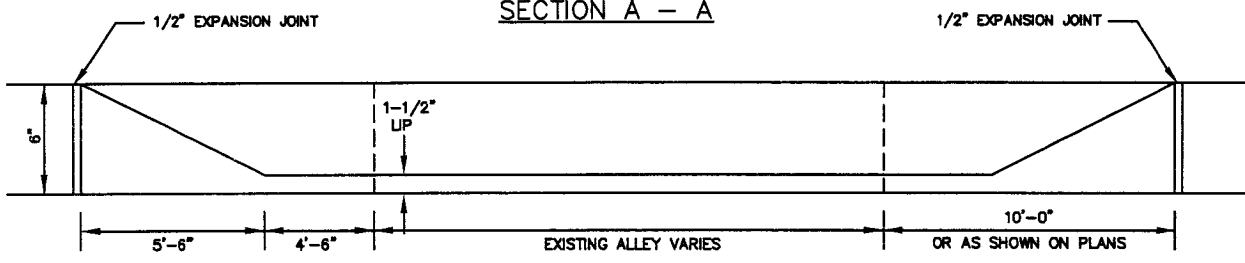

CURB LINE PROFILE

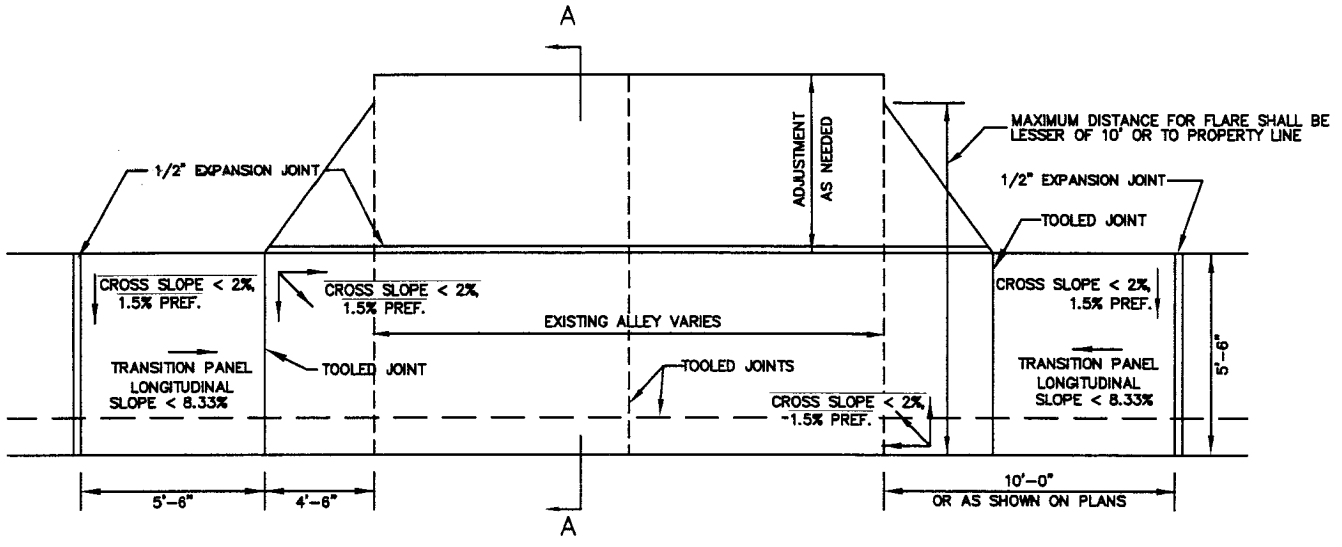

P.C.C. ALLEY/DRIVEWAY APPROACH - 8"
ADJACENT TO COMBINATION CURB AND SIDEWALK

NOTE:
ALL FOAM/FELT EXPANSION JOINTS SHALL BE CAULKED WITH SELF LEVELING CAULK, COVERING THE SURFACE OF THE JOINT.
RUBBERIZED EXPANSION JOINTS ARE NOT REQUIRED TO BE CAULKED.

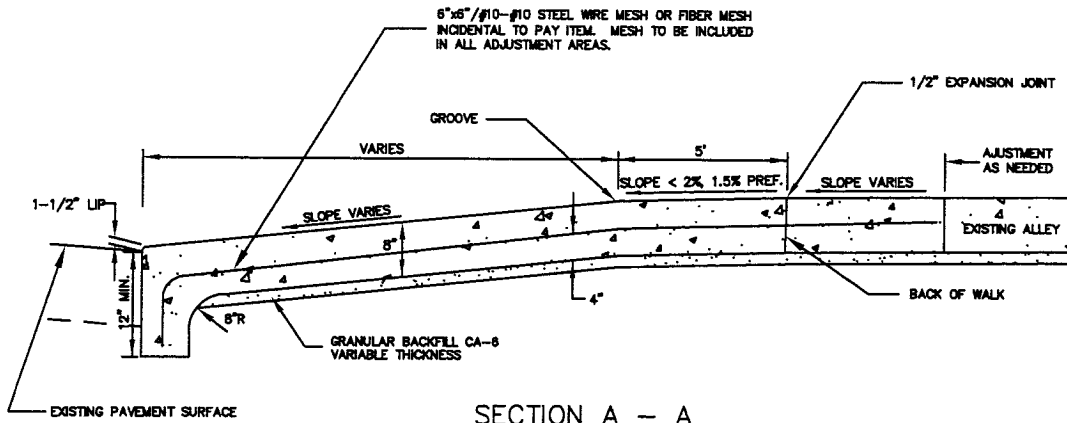

SECTION A - A

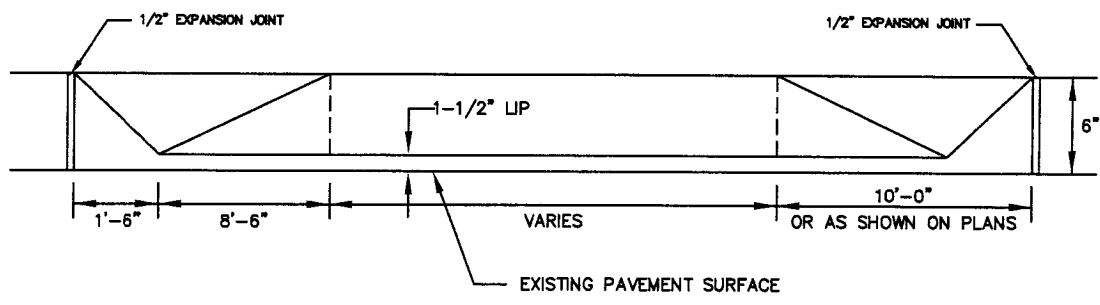

CURB LINE PROFILE

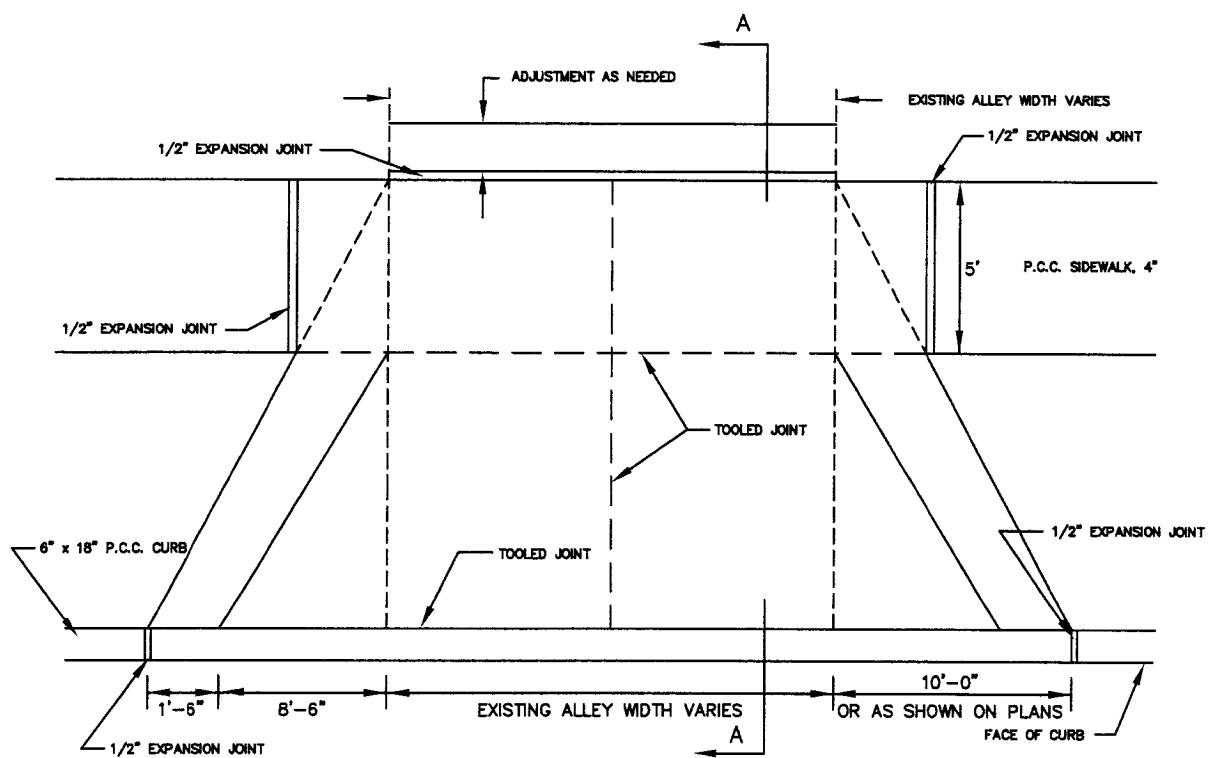

P.C.C. DRIVEWAY/ALLEY APPROACH, 8"
ADJACENT TO PROPERTY LINE SIDEWALK

NOTE:
ALL FOAM/FELT EXPANSION JOINTS SHALL BE CAULKED WITH SELF LEVELING CAULK, COVERING THE SURFACE OF THE JOINT.
RUBBERIZED EXPANSION JOINTS ARE NOT REQUIRED TO BE CAULKED.



CITY OF PEORIA

PUBLIC WORKS DEPT. - ENGINEERING DIV.

P.C.C. DRIVEWAY/ALLEY APPROACH, 8"

DRAWN BY:

BY: SML

DATE:

REVISED: 04/06/16

NOTES

1. JOINTS BETWEEN PAVING BRICKS SHALL BE FILLED WITH TORPEDO SAND BY BROOMING.
2. THE BRICK SURFACE INSTALLATION PAY ITEM SHALL INCLUDE THE FOLLOWING:
 - 4" x 8" x 2-1/4" RED CLAY PAVING BRICKS.
 - TORPEDO SAND BEDDING AND JOINT FILL.
 - SOLDIER COURSE OR METAL EDGING.

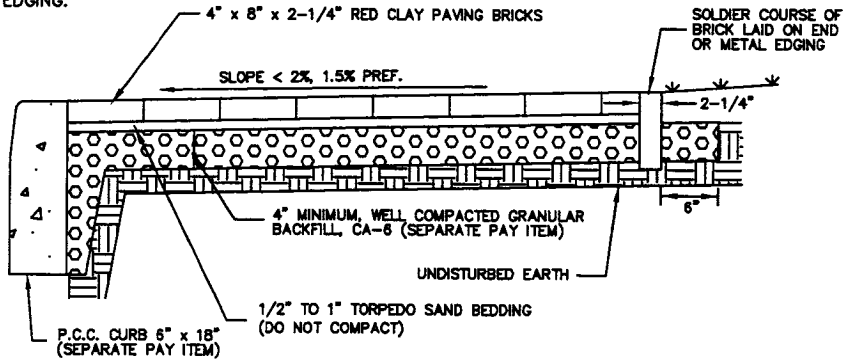

CURB LINE SIDEWALK

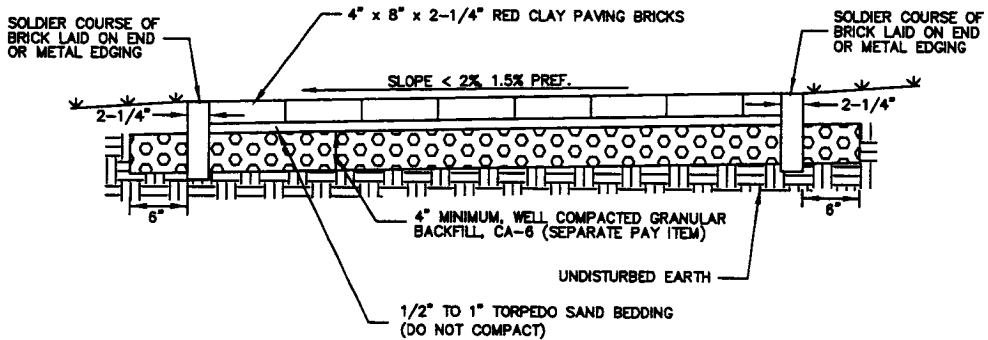

PROPERTY LINE SIDEWALK

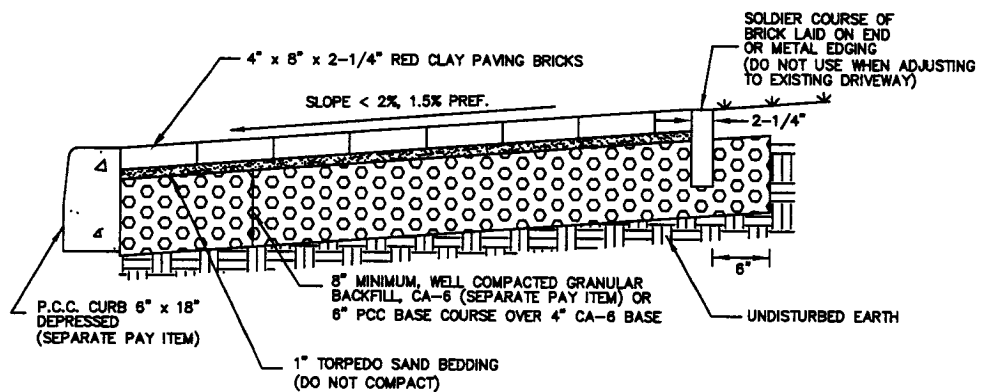

DRIVEWAY TREATMENT

BRICK SURFACE INSTALLATION

