

SUBMITTED BY:

ADVANCED ELECTRIC CO.

CONTRACTOR'S NAME

663 S. FIFTH AVE. P.O. BOX 265

CONTRACTOR'S ADDRESS

CANTON, IL 61520

CITY, STATE, ZIP

STATE OF ILLINOIS

CITY OF PEORIA

COUNTY OF PEORIA

SPECIFICATIONS, PLANS, MATERIAL
QUANTITIES AND CONTRACT PROPOSAL

FOR

**NORTH WISCONSIN AVENUE ORNAMENTAL LIGHTING
(McCLURE AVENUE TO EAST REPUBLIC STREET)**

City Project No.: CDIST-16

TO BE CONSTRUCTED UNDER THE PROVISIONS OF
THE CITY OF PEORIA



BID OPENING: Thursday, August 4, 2016 at 11:00 AM
CONTRACT AWARDED: Tues. August 23, 2016 #16-284

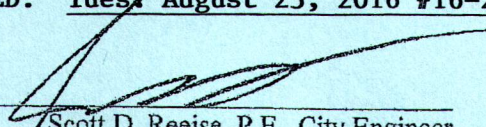

Scott D. Reeise, P.E., City Engineer

**CITY OF PEORIA
CONTRACT**

This agreement, made and entered into this _____ day of August, 2016, by and between the City of Peoria, an Illinois Municipal Corporation, Party of The First Part, and ADVANCED ELECTRIC CO., Party of The Second Part for the improvement known as the NORTH WISCONSIN AVENUE ORNAMENTAL LIGHTING PROJECT (MCCLURE AVE TO EAST REPUBLIC STREET);

WITNESSETH: That for and in consideration of the payments and agreements mentioned in the proposal hereto attached, to be made and performed by the Party of the First Part, and according to the terms expressed in the bond referring to these presents, the Party of The Second Part agrees with said Party of The First Part, at his/their own proper cost and expense to furnish and deliver all the work, materials and supplies in accordance with the specifications contained in said proposal, and in full compliance with all the terms of this agreement, for the amount of ONE HUNDRED FIFTEEN THOUSAND THREE HUNDRED SIXTY FOUR AND 14/100 DOLLARS (\$115,364.14).

IT IS UNDERSTOOD AND AGREED that the instructions to bidders, proposal, bid, specifications, performance bond and maintenance bond are component parts of this contract and shall be deemed a part hereof. It is also understood and agreed that the contractor shall not assign, transfer, convey or otherwise dispose of this contract, or his right to execute it, or his right, title or interest in or to it or any part thereof, unless the previous written consent of the City Manager of the City of Peoria shall first be obtained thereto.

EMPLOYEE/EMPLOYMENT RESTRICTIONS – THE CONTRACTOR:

THE CONTRACTOR (hereinafter referred to as “SERVICE PROVIDER”) agrees, as a condition of accepting this contract with the City of Peoria, that, for a period of one (1) year following completion of this contract, it shall be prohibited from hiring, directly or indirectly, any City employee or official who was involved, directly or indirectly in: (1) the selection and/or recommendation to select the SERVICE PROVIDER for performance of this contract; (2) coordinating the efforts of the SERVICE PROVIDER in the consummation or completion of this contract; or (3) monitoring or determining the performance of the SERVICE PROVIDER. The SERVICE PROVIDER further acknowledges and agrees that, upon the City’s determination that a violation of this provision has occurred, the penalty imposed, at the sole discretion of the City, may include one or more of the following: (1) cancellation of any other contract(s) between the City of Peoria and the SERVICE PROVIDER; (2) disqualification of the SERVICE PROVIDER from bidding or being awarded future contracts with the City of Peoria for a period of two [2] years; and/or (3) payment of liquidated damages to the City of Peoria in the amount of TWENTY FIVE THOUSAND DOLLARS (\$25,000.00). This does not apply to any City Employee involved in the 2011-12 reduction in force; nor does it apply to parties taking the Early Retirement incentive offered by the City from November 1, 2011 through November 1, 2012.

IN WITNESS WHEREOF, the said parties have executed these presents on the date above mentioned.

THE CITY OF PEORIA

BY: *Pattys [Signature]*
City Manager

ATTEST: *Beth Ball*
City Clerk

EXAMINED AND APPROVED:
Donald B. Leist
Corporation Counsel

PARTY OF THE SECOND PART

Advanced Electric Co.
(name of individual, firm or corporation)

BY: *Rosalie Okwanga*
(member of firm or officer of corporation)

(If a Co-Partnership)

(seal)

(seal)

Partners doing business under the firm name
of _____ (seal)
(PARTY OF THE SECOND PART)

(If an Individual)

(seal)
(PARTY OF THE SECOND PART)

RECEIVED
MAY 19 1968
U.S. AIR FORCE
OFFICE OF THE
SECRETARY
WASHINGTON, D.C.

CITY OF PEORIA
PERFORMANCE BOND

Bond Number 9178045

KNOW ALL MEN BY THESE PRESENTS, That I/we ADVANCED ELECTRIC CO.

an individual, of _____

a co-partnership, of _____

a corporation organized under the laws of the State of Illinois

as Principal, and Washington International Insurance Company

a corporation organized and existing under the laws of the State of New Hampshire with authority to do business in the State of Illinois, as Surety, are held and firmly bound unto the City of

Peoria, Peoria County, State of Illinois, in the penal sum of ONE HUNDRED FIFTEEN THOUSAND THREE HUNDRED SIXTY FOUR AND 14/100 DOLLARS (\$115,364.14) lawful money of the United States, well and truly to be paid unto said City of Peoria for the payment of which we bind ourselves, our heirs, executors, administrators, successors, and assigns, jointly, severally, and firmly by these presents.

THE CONDITION OF THE FOREGOING OBLIGATIONS IS SUCH that whereas, the said Principal has entered into a contract with the City of Peoria for North WISCONSIN AVENUE ORNAMENTAL LIGHTING IMPROVEMENT (MCCLURE TO E REPUBLIC) in accordance with the terms and conditions of said contract, which is hereby referred to and made a part hereof as if fully set forth herein;

NOW, THEREFOR, the condition of this obligation is such, that if the above bounden Principal shall well and truly keep, do and perform, each and every, all and singular, the matters and things in said contract set forth and specified to be by said Principal kept, done and performed, at the times and in the manner in said contract specified, or shall pay over, make good and reimburse the City of Peoria, all loss and damage which it may sustain by reason of the failure or default on the part of the Principal so to do, then this obligation shall be null and void; otherwise to remain in full force and effect.

IN WITNESS WHEREOF, we have duly executed the foregoing Obligation this 29th day of August, 2016.

FOR THE CITY OF PEORIA

EXAMINED AND APPROVED:
Donald B. Leist
Corporation Counsel

Advanced Electric Co.
Principal

Rosalie Obwange

Washington International Insurance Company

Ronald A. Koopman
Sureties
Ronald A Koopman

STATE OF Illinois)
) SS
COUNTY OF Macon)

I, Glenda Hoffman, a Notary Public in and for said County, in the State aforesaid, do hereby certify that Ronald A Koopman, who is personally known to me to be the same person who signed the above foregoing instrument as the Attorney in Fact for Washington International Insurance Company, appeared before me this day in person and acknowledged that he signed the name of Ronald A Koopman, thereto, as his Principal, and his own name as Attorney in Fact, as the free and voluntary act of his said Principal for the uses and purposes therein set forth, and that he executed the said instrument under authority given him by his said Principal.

Given under my hand and Notarial Seal, this 29th day of August, 2016.

Glenda Hoffman
Notary Public



NAS SURETY GROUP

NORTH AMERICAN SPECIALTY INSURANCE COMPANY
WASHINGTON INTERNATIONAL INSURANCE COMPANY

GENERAL POWER OF ATTORNEY

KNOW ALL MEN BY THESE PRESENTS, THAT North American Specialty Insurance Company, a corporation duly organized and existing under laws of the State of New Hampshire, and having its principal office in the City of Manchester, New Hampshire, and Washington International Insurance Company, a corporation organized and existing under the laws of the State of New Hampshire and having its principal office in the City of Schaumburg, Illinois, each does hereby make, constitute and appoint:

KEVIN J. BREHENY, RANDY S. CANNADY, GLENDA HOFFMAN, RONALD A. KOOPMAN,
TIM R. PATTON and GREG NUSSBAUM

JOINTLY OR SEVERALLY

Its true and lawful Attorney(s)-in-Fact, to make, execute, seal and deliver, for and on its behalf and as its act and deed, bonds or other writings obligatory in the nature of a bond on behalf of each of said Companies, as surety, on contracts of suretyship as are or may be required or permitted by law, regulation, contract or otherwise, provided that no bond or undertaking or contract or suretyship executed under this authority shall exceed the amount of:

FIFTY MILLION (\$50,000,000.00) DOLLARS

This Power of Attorney is granted and is signed by facsimile under and by the authority of the following Resolutions adopted by the Boards of Directors of both North American Specialty Insurance Company and Washington International Insurance Company at meetings duly called and held on the 9th of May, 2012:

"RESOLVED, that any two of the Presidents, any Managing Director, any Senior Vice President, any Vice President, any Assistant Vice President, the Secretary or any Assistant Secretary be, and each or any of them hereby is authorized to execute a Power of Attorney qualifying the attorney named in the given Power of Attorney to execute on behalf of the Company bonds, undertakings and all contracts of surety, and that each or any of them hereby is authorized to attest to the execution of any such Power of Attorney and to attach therein the seal of the Company; and it is

FURTHER RESOLVED, that the signature of such officers and the seal of the Company may be affixed to any such Power of Attorney or to any certificate relating thereto by facsimile, and any such Power of Attorney or certificate bearing such facsimile signatures or facsimile seal shall be binding upon the Company when so affixed and in the future with regard to any bond, undertaking or contract of surety to which it is attached."



By [Signature]
Steven P. Anderson, Senior Vice President of Washington International Insurance Company
& Senior Vice President of North American Specialty Insurance Company



By [Signature]
Michael A. Ito, Senior Vice President of Washington International Insurance Company
& Senior Vice President of North American Specialty Insurance Company

IN WITNESS WHEREOF, North American Specialty Insurance Company and Washington International Insurance Company have caused their official seals to be hereunto affixed, and these presents to be signed by their authorized officers this 8th day of August, 2014.

North American Specialty Insurance Company
Washington International Insurance Company

State of Illinois
County of Cook ss:

On this 8th day of August, 2014, before me, a Notary Public personally appeared Steven P. Anderson, Senior Vice President of Washington International Insurance Company and Senior Vice President of North American Specialty Insurance Company and Michael A. Ito, Vice President of Washington International Insurance Company and Vice President of North American Specialty Insurance Company, personally known to me, who being by me duly sworn, acknowledged that they signed the above Power of Attorney as officers of and acknowledged said instrument to be the voluntary act and deed of their respective companies.



M. Kenny, Notary Public

I, Jeffrey Goldberg, the duly elected Assistant Secretary of North American Specialty Insurance Company and Washington International Insurance Company, do hereby certify that the above and foregoing is a true and correct copy of a Power of Attorney given by said North American Specialty Insurance Company and Washington International Insurance Company, which is still in full force and effect.

IN WITNESS WHEREOF, I have set my hand and affixed the seals of the Companies this 29th day of August, 2016.

[Signature]
Jeffrey Goldberg, Vice President & Assistant Secretary of
Washington International Insurance Company & North American Specialty Insurance Company

SUBMITTED BY:

ADVANCED ELECTRIC CO.

CONTRACTOR'S NAME

663 S. FIFTH AVE. P.O. BOX 265

CONTRACTOR'S ADDRESS

CANTON, IL 61520

CITY, STATE, ZIP

STATE OF ILLINOIS

CITY OF PEORIA

COUNTY OF PEORIA

SPECIFICATIONS, PLANS, MATERIAL
QUANTITIES AND CONTRACT PROPOSAL

FOR

NORTH WISCONSIN AVENUE ORNAMENTAL LIGHTING
(McCLURE AVENUE TO EAST REPUBLIC STREET)

City Project No.: CDIST-16

TO BE CONSTRUCTED UNDER THE PROVISIONS OF
THE CITY OF PEORIA

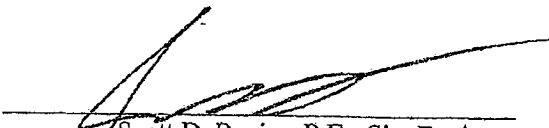

BID OPENING: Thursday, August 4, 2016 at 11:00 AM

Scott D. Reeise, P.E., City Engineer

The Fifty-dollar (\$50.00) processing fee can be paid by check, payable to the City of Peoria, or online through the State of Illinois E-Pay process. To pay online go to www.illinoispay.com and follow the instructions. The only exception to payment of the processing fee is neighborhood associations.

Although all vendors are encouraged to obtain an EEO Certification Number, you do not need a number to respond to a bid. The number is only required prior to the award of a contract.

EEO CERTIFICATION (Check one):

We are renewing or applying for an EEO Certification Number. Employer Report Form CC-1 is completed and enclosed.

We have a current EEO Certification Number on file with the City.

Our EEO Certification Number: RENEWAL # APPLIED FOR

-
22. ~~The City of Peoria can increase or decrease this contract by 25% to meet budgetary needs.~~
23. The undersigned submits herewith this schedule of prices covering the work to be performed under this contract



EQUAL OPPORTUNITY OFFICE
 419 FULTON STREET RM 403
 PEORIA, ILLINOIS 61602
 TELEPHONE: 309-494-8530

EMPLOYER REPORT FORM CC-1

Please read instructions before completing this form. Improperly completed forms will not be processed. Use black or dark blue ink. Type or print legibly. Return the completed form to the above address or submit electronically to eeo@peoriagov.org. Pursuant to Chapter 17 of the Peoria Municipal Code, a fifty-dollar (\$50.00) processing fee must be submitted with each Employer Report Form CC-1.

SECTION I. PURPOSE FOR WHICH REPORT IS FILED

- Initial registration for contract eligibility
 Renewal registration → EEO number is

0 0 2 0 5 - 1 3 1 2 3 1

SECTION II. TYPE OF REPORT SUBMITTED (Check one only)

SINGLE-ESTABLISHMENT REPORT.

This employer conducts its operations from a single location. This report contains employment figures for that location.

MULTI-ESTABLISHMENT CONSOLIDATED REPORT:

This employer operates from multiple locations. This report is filed by the headquarters and consolidates the employment figures for all locations.

SECTION III. COMPANY IDENTIFICATION

NAME			
ADVANCED ELECTRIC CO.			
ADDRESS			
663 S. FIFTH AVE. P.O. BOX 265			
CITY	COUNTY	STATE	ZIP
CANTON	FULTON	IL	61520
CONTACT PERSON / TITLE		CONTACT TELEPHONE	
JANICE OATMAN OFFICE MANAGER		309-647-4463	
E-MAIL: advelec@aol.com			

SECTION IV. FORM OF ORGANIZATION

- INDIVIDUAL OR SOLE PROPRIETOR CORPORATION - NOT FOR PROFIT OTHER-EXPLAIN BELOW
 PARTNERSHIP GOVERNMENT ENTITY
 CORPORATION - FOR PROFIT EDUCATIONAL INSTITUTION

SECTION V. CONTRACTING AGENCY

Company will be conducting business with:

City of Peoria County of Peoria Greater Peoria Sanitary District

Disclosure of the information requested in this form is required of those companies seeking financial assistance from the City of Peoria or seeking to provide goods and/or services to the City of Peoria, County of Peoria, and/or the Greater Peoria Sanitary District (hereinafter GPSD) for remuneration. Improperly completed forms will not be processed. The \$50 processing fee must be submitted with each Employer Report Form CC-1 or paid separately online at www.illinoispay.com the only exception to payment of the processing fee is neighborhood associations. Make checks payable to the "City of Peoria".

Method of Payment Cash Check Credit Card (E-pay)

NORTH WISCONSIN AVENUE ORNAMENTAL LIGHTING

(McCLURE AVENUE TO EAST REPUBLIC STREET)

SCHEDULE OF PRICES

<u>Item</u>	<u>Quantity</u>	<u>Unit</u>	<u>Unit Price</u>	<u>Extension</u>
Traffic Control and Protection	1	LSum	\$ 2,222.04	\$ 2,222.04
Removal and Disposal of Unsuitable Material	30	C.Y.	\$ 1,280.10	\$ 1,280.10
Portland Cement Concrete Sidewalk	100	S.F.	\$ 22.00	\$ 2,200.00
Concrete Handhole	2	Ea.	\$ 1,100.00	\$ 2,200.00
Conduit (2")	2860	Ft.	\$ 8.00	\$ 22,880.00
Light Pole Foundation	25	Ea.	\$ 567.00	\$ 14,175.00
Light Pole, Decorative	25	Ea.	\$ 2,368.80	\$ 59,220.00
ELCBL, In Conduit, 600V XLP, 1/c, No. 6, Green	3550	Ft.	\$ 1.04	\$ 3,692.00
ELCBL, In Conduit, 600V XLP, 1/c, No. 6, Black	7100	Ft.	\$ 1.05	\$ 7,455.00

TOTAL BID \$ 115,364.14

Continued on next page



**CITY OF PEORIA
SUB-CONTRACTOR UTILIZATION STATEMENT**

Section I (select all that apply)

MBE/WBE Subcontractor(s) will be utilized on this project
 Non MBE/WBE Subcontractor(s) will be utilized on this project

Section II: Prime Contractor

Name: ADVANCED ELECTRIC CO.
 Address: 663 S. FIFTH AVE. CANTON, IL 61520
 Phone: 309-647-4463
 Contact Person: JANICE OATMAN
 Email: advelec@aol.com

Project

Name: _____
 Total Contract Value: _____

Ownership Status: MBE _____ WBE _____ M/WBE _____ Non-M/WBE

Section III: Selected Subcontractors

Subcontractor Name	MBE, WBE or Non M/WBE	Amount	% of Total Contract	Scope of Work
ELECTRICAL RESOURCE MGMT	MBE	\$47,650.00	41%	HOLOPHANE ASSEMBLY
TOTALS				

**If more than seven firms are utilized, please copy the form and attach the additional information.*

Section IV: Subcontractors that submitted bids but were not selected (M/WBE Only)

Subcontractor Name	Scope of Work Bid	Denial Reason

**If more than seven firms submitted quotes, please copy the form and attach the additional information.*

-----Continues on next page-----

For Office Use Only
 Reviewed by: _____

Section V: Subcontractors Contacted (M/WBE Only)

Subcontractor Name	Method of Contact	Contact Outcome

**If more than six firms were contacted, please copy the form and attach the additional information*

Section IV

The City of Peoria is committed to promoting equal opportunity and has established the following subcontractor utilization goals for city funded construction projects: 10% MBE and 5% WBE. Prime Contractors have an obligation to make a good faith effort to advance the city's commitment to increase diversity among the firms working on city construction projects.

This form must be completed and submitted with bid proposals. ALL subcontractors intended for use on this project shall be listed in the Section III above; along with the total amount to be paid to the subcontractors; percentage of total contract; and scope of work. If for whatever reason the prime contractor has to utilize a subcontractor not listed above, they must submit a Notification of Change in Participation.

The undersigned certifies that the information included herein is true and correct; the subcontractors listed above have agreed to perform the scope of work described. The undersigned further certifies that it has no controlling, dominating or conflict of interest in any of the listed subcontractors.

Signature of Prime Contractor

Date

For Office Use Only
Reviewed by: _____

Org.: May 2008
Revised: Feb. 2011



**CITY OF PEORIA
M/WBE PARTICIPATION WAIVER REQUEST**

PRIME CONTRACTOR

Name: _____
Address: _____
Phone: _____
Contact Person: _____

PROJECT

Name: _____

We hereby request to waive all of the MBE and WBE participation goals on the above named project and self-perform all work for the following reason(s). The firm further affirms that the stated reasons and documents provided are true and correct and not misleading: **(CHECK ALL THAT APPLY. SPECIFIC SUPPORTING DOCUMENTATION MUST BE SUBMITTED WHERE INDICATED.)**

1. No MBEs/WBEs responded to our invitation to bid. _____
2. No subcontracting opportunities exist. (Attach explanation) _____
3. The award of subcontract(s) is impracticable. (Attach explanation) _____

SIGNED: _____
(Company Official)

DATE: _____

FOR OFFICE USE ONLY

APPROVED.

DISAPPROVED.

REVIEWED BY _____

DATE _____

MTE/md

Michael T. Everett,
Business Manager

Michael Everett
Sincerely

This letter is to certify that Advanced Electric is signatory to our collective bargaining agreement. Under this agreement, they are required to participate and fund the apprenticeship program.

To Whom It May Concern:

June 20, 2007

400 North Jefferson Avenue
309-673-3691
309-673-4747
Fax
Baltimore, MD 21203



Local Union, No. 34

Dennis Greiner, Rec. Sec.
Michael T. Everett, Bus. Manager

Dennis Shelton, President
Michael T. Everett, Fin. Sec.

Table of Contents

PART 1- PROPOSAL.....- 1 -

NOTICE TO BIDDERS.....- 2 -

PROPOSAL- 4 -

NORTH WISCONSIN AVENUE ORNAMENTAL LIGHTING- 8 -

(McCLURE AVENUE TO EAST REPUBLIC STREET).....- 8 -

SCHEDULE OF PRICES- 8 -

SIGNATURE PAGE.....- 9 -

PROPOSAL BID BOND- 10 -

SUB-CONTRACTOR UTILIZATION STATEMENT- 11 -

M/WBE PARTICIPATION WAIVER REQUEST- 13 -

PART 2- GENERAL CONDITIONS- 14 -

DESCRIPTION OF WORK- 15 -

CONTACT INFORMATION.....- 15 -

TIME OF THE ESSENCE.....- 15 -

FAILURE TO COMPLETE WORK ON TIME.....- 15 -

PROSECUTION AND PROGRESS OF WORK.....- 15 -

DEFINITION OF TERMS.....- 15 -

RESPONSIBILITY FOR DAMAGE CLAIMS- 16 -

QUALIFICATION OF CONTRACTORS- 16 -

CONTRACTOR’S INSURANCE- 17 -

PROOF OF CARRIAGE OF INSURANCE- 18 -

SUBSTANCE ABUSE PREVENTION PROGRAM- 19 -

EXISTING UNDERGROUND FACILITIES- 19 -

COOPERATION WITH UTILITY COMPANIES- 19 -

NOTIFICATION OF UTILITIES PRIOR TO CONSTRUCTION- 19 -

J.U.L.I.E. SYSTEM- 19 -

NOTIFICATION OF THE PUBLIC- 20 -

CERTIFIED PAYROLL REQUIREMENTS.....- 20 -

PREVAILING WAGE PROVISION- 21 -

LANDSCAPING- 27 -

PROTECTION OF THE PUBLIC.....- 27 -

TRAFFIC CONTROL & PROTECTION- 27 -

ITEMS DESIGNATED FOR REMOVAL AND EXCAVATION- 28 -

SALVAGING EXISTING MATERIALS	- 28 -
CITY SIGNS.....	- 29 -
CONSTRUCTION DEBRIS.....	- 29 -
DAMAGE TO EXISTING TREES	- 29 -
GUARANTEE PERIOD.....	- 29 -
PART 3-SPECIAL PROVISIONS	- 30 -
MEASUREMENT METHODS	- 31 -
EROSION CONTROL	- 31 -
UNDERGROUND CONDITIONS	- 31 -
PORTLAND CEMENT CONCRETE SIDEWALK.....	- 31 -
REMOVAL AND DISPOSAL OF UNSUITABLE MATERIAL	- 32 -
STREET LIGHTS.....	- 32 -
LIGHT POLE, DECORATIVE	- 34 -
LIGHT POLE FOUNDATION	- 36 -
CONCRETE HANDHOLE	- 37 -
ELECTRICAL CONDUCTORS – SLACK REQUIREMENTS	- 37 -
GROUNDING	- 37 -
CONDUIT.....	- 37 -
WIRING TESTS.....	- 38 -
VOLTAGE REGULATION AND CURRENT BALANCE TESTS	- 39 -
WIRING TEST LOG SHEET.....	- 40 -
PART 4- EQUAL OPPORTUNITY REQUIREMENTS.....	- 41 -
EEO CONTRACT COMPLIANCE CLAUSE.....	- 42 -
REQUIREMENTS FOR GOOD-FAITH EFFORTS	- 45 -
HUMAN RIGHTS ACT	- 52 -
APPENDIX A	- 53 -
EEO INFORMATION.....	- 54 -
MINORITY AND WOMEN BUSINESS ENTERPRISE DIRECTORY	- 55 -
EQUAL EMPLOYMENT OPPORTUNITY.....	- 55 -
CONTRACT DELIVERABLES	- 56 -
SUBCONTRACTOR PAYMENT FORM.....	- 57 -
MONTHLY WORKFORCE ANALYSIS.....	- 58 -
NOTIFICATION OF CHANGE IN PARTICIPATION	- 59 -
MISCELLANEOUS	- 60 -
SAMPLE CONTRACT	- 61 -

SAMPLE PERFORMANCE BOND - 62 -
CONSTRUCTION DEBRIS MANIFEST..... - 64 -
SUBSTANCE ABUSE PREVENTION PROGRAM CERTIFICATION - 65 -
SUB-CONTRACTOR FINAL PAYMENT NOTIFICATION FORM..... - 66 -

PART 1- PROPOSAL

STATE OF ILLINOIS
CITY OF PEORIA

NOTICE TO BIDDERS

1. Time and Place of Opening Bids.

Sealed proposal for the improvement described herein will be received at the Office of the City Engineer, 3505 N. Dries Lane, Peoria, Illinois, until **11:00 A.M., Thursday, August 4, 2016**, and at that time publicly opened and read.

2. Description of Work.

(A) Proposed improvement is officially known as the **NORTH WISCONSIN AVENUE ORNAMENTAL LIGHTING (McCLURE AVENUE TO EAST REPUBLIC STREET)**

(B) The proposed improvement consists of the installation of twenty-five (25) new decorative street lights and services and other incidental and collateral work as shown on the plans and as specified herein along North Wisconsin Avenue from McClure Avenue southerly to East Republic Avenue. This work shall be done in accordance with the Standard Specifications for Road and Bridge Construction adopted April 1, 2016, at locations designated in this document or as directed by the City. Necessary adjustments, incidentals and appurtenant items shall be constructed as directed by the City.

3. Instruction to Bidders.

(A) Specifications and proposal forms are issued through the Office of the City Engineer, Public Works Facility, 3505 North Dries Lane, Peoria, IL, Phone number 309-494-8800. Before plans and specifications may be obtained, contractors must be pre-qualified. Electronic documents are available by providing contact information (company name, contact name, phone number, fax number and email address) in an email request to pwdropbox@peoriagov.org.

(B) All proposals must be accompanied by a proposal guaranty as provided in Section 102 of the "Standard Specifications for Road and Bridge Construction" prepared by the Illinois Department of Transportation: a Bid Bond, or a proposal guarantee of cash, a Bank Cashier Check, or a properly certified check made payable to the City of Peoria, for not less than five percent (5%) of the amount of the bid.

(C) Proposers shall submit their response in a sealed envelope which shall be clearly labeled with the organization/individual name and address. Proposers are requested to indicate in the LOWER LEFT HAND CORNER OF THEIR ENVELOPE THE PROJECT NAME: "**NORTH WISCONSIN AVENUE ORNAMENTAL LIGHTING (McCLURE AVENUE TO EAST REPUBLIC STREET)**," and the DATE AND TIME the request is due.

- (D) All bids are to be mailed or delivered to the City of Peoria, 3505 N. Dries Lane, Peoria, Illinois, 61604 by **11:00 A.M, Thursday, August 4, 2016**. Proposals will not be accepted by FAX, e-mail, internet, telephone or telegraphic means. Information regarding the proposal can be obtained by calling the City of Peoria. Contact Stephen Letsky, P.E. at 309-494-8800.
- (E) No response will be opened which has be received after the closing time specified in the BID document and it will be returned unopened to the Proposer.
- (F) The Contract, if awarded, will be on the basis of materials and equipment specified or described in the Bidding Documents without consideration of possible substitute or "or-equal" items. Whenever it is specified or described in the Bidding Documents that a substitute or "or-equal" item of material or equipment may be furnished or used by the Contractor if acceptable to the Owners' Representative, approval must be obtained prior to the bid opening. The request to use substitute items must be accompanied by complete specifications of the substitute items.
- (G) Unit costs must be clearly identified for each component requested by the proposal document or otherwise submitted by the Proposer. All costs shall be stated in U.S. dollars. Each pay item should have a unit price, a bid will be declared unacceptable if a unit price is not shown. In case of mistake in extension of cost, unit cost shall govern. All costing must be typewritten or written in ink. No erasures are permitted. Mistakes must be crossed out and corrections typewritten or written in ink adjacent thereto and initialed in ink by the party signing the proposal or his/her authorized Representative.
- (H) Each proposal must be signed by the Proposer with its usual signature. Proposals by partnerships must be signed with the partnership name by one of the members of the partnership, or by an authorized representative, followed by the signature and title of the person signing. Proposals by corporations must be signed with the name of the corporation, followed by the signature and title of person authorized to bind it on the matter. All signatures must be in ink.

4. Rejection of Bids.

The City of Peoria reserves the right to reject any or all proposals as provided in Section 102 of the "Standard Specifications for Road and Bridge Construction," and LRS6 Recurring Special Provision, prepared by the Department of Transportation of the State of Illinois.

STATE OF ILLINOIS
CITY OF PEORIA

**PROPOSAL
TO THE CITY OF PEORIA:**

1. Proposal of _____
i. (Name and Address of Bidder)
for the improvement designated in Paragraph 2 below The proposed improvement consists of the installation of twenty-five (25) new decorative street lights and services and other incidental and collateral work as shown on the plans and as specified herein along North Wisconsin Avenue from McClure Avenue southerly to East Republic Avenue. This work shall be done in accordance with the Standard Specifications for Road and Bridge Construction adopted April 1, 2016, or as directed by the City. The Contractor shall furnish all materials and equipment, and provide all traffic control. Necessary adjustments, incidentals and appurtenant items shall be constructed as directed by the City.
2. The specifications for the proposed improvement are those prepared by the Austin Engineering Company, Inc., which specifications are designated as **North Wisconsin Avenue Ornamental Lighting (McClure Avenue to East Republic Street)**.
3. The specifications herein referred to are the "Standard Specifications for Road and Bridge Construction," prepared by the Department of Transportation of the State of Illinois and adopted by said Department on April 1, 2016. The undersigned agrees to accept, as part of the contract, the Special Provisions contained within this proposal.
4. The undersigned declares that they will comply with the applicable provisions of Division 100, General Requirements and Covenants.
5. The undersigned agrees to complete the work, by **November 23, 2016** unless additional time is granted in accordance with Article 108.08 of the Specifications.
6. The City reserves the right to cancel the whole or any part of the contract, if the contractor fails to perform any of the provisions in the contract or fails to make delivery within the time stated. The Cancellation notice will be written and delivered by certified mail to contractor's address on record. In the event the contract is canceled, the vendor may be declared an irresponsible vendor by the City Manager, and as a result may be disqualified from doing business with the City for the period of one year in accordance with City Ordinance section 10-102. The contractor will not be liable to perform if situations arise by reason of strikes, acts of god or the public enemy, acts of the City, fires, or floods.
7. In case of default by the contractor, the City will procure the articles or services from other sources and hold the contractor responsible for any excess cost incurred.
8. Accompanying this proposal is a bid bond, certified check, or cashier's check complying with the requirements of the Specifications, made payable to the City Treasurer of the City of Peoria, Illinois. If this proposal is accepted and the undersigned fails to execute a contract and contract bond as required, it is hereby agreed that the check shall be forfeited to the awarding authority.

The amount of the check or draft is \$ _____.

Attach Cashier's Check or Certified Check Here

9. The undersigned certifies that it is not delinquent in the payment of any indebtedness, tax, fee or fine owed to the City of Peoria, or in the payment of any tax administered by the Illinois Department of Revenue, and is in compliance with the terms and conditions of Sec. 10-109 of the Peoria City Code and 65 ILCS 5/11-42.1-1.
10. Unit costs must be clearly identified for each component requested by the contract document or otherwise submitted by the Proposer. All costs shall be stated in U.S. dollars. Each pay item should have a unit price, a bid will be declared unacceptable if a unit price is not shown. In case of mistake in extension of cost, unit cost shall govern. All costing must be typewritten or written in ink. No erasures are permitted. Mistakes must be crossed out and corrections typewritten or written in ink adjacent thereto and initialed in ink by the party signing the proposal or his/her authorized Representative.
11. The city is exempt, by law, from paying State and City Retailers Occupation Tax, State Service Occupation Tax, State Use Tax and Federal Excise Tax. The City will execute tax exemption certificates whenever required. The unit prices should be exclusive of all taxes. In the event the unit price includes taxes, the Proposer must show the amount of tax included in the unit price.
12. The contract will be subject to and governed by the rules and regulations of the Illinois Human Rights Act 775ILCS5/1-101 et seq. and as amended. And the provision of chapter 775 of the Illinois compiled Statues 5/2-105 on sexual Harassment policies.
13. With the execution of this BID, the Proposer is certifying to the non-collusion in the preparation and submittal. The Response must be properly executed by the Proposers or the response will not be considered for selection.
14. The successful vendor agrees to furnish the material or services according to the City's plans, specifications and conditions and at prices specified herein.
15. The successful Proposer shall obtain, at its own expense, all permits and licenses which may be required to complete the contract.
16. Where special conditions are written in the specifications, these conditions shall take precedence over any conditions listed under the "Instructions to Bidders."
17. This contract will be governed by the laws of the State of Illinois.
18. "The contractor/vendor will not discriminate against any employee or applicant for employment because of race, color, religion, sex, sexual harassment, ancestry, national origin, place of birth, age or a physical or mental handicap which would not interfere with the efficient performances of the job in question. The contractor/vendor will take affirmative action to comply with the provision of this division and will require any subcontractor to submit to the City written commitment to comply

with this division. The contractor/vendor will distribute copies of this commitment to all persons who participate in recruitment, screening, referral and selection of job applicants, prospective job applicants, member or prospective subcontractors.”

“The contractor/vendor agrees that the provision of division 4 Article III of Chapter 17 of the code of the City of Peoria is hereby incorporated by reference, as if set out verbatim.”

19. The undersigned firm certifies that it has not been convicted of bribery or attempting to bribe an officer or employee of the City of Peoria, nor has the firm made an admission of guilt of such conduct which is a matter of record, nor has an official, agent, or employee of the firm committed bribery or attempted bribery on behalf of the firm and pursuant to the direction or authorization of a responsible official of the firm. The undersigned firm further certifies that it is not barred from contracting with any unit of Federal, State or local government as a result of a violation of State laws prohibiting bid-rigging or bid-rotating and has not been suspended or debarred from receiving federal funding.
20. EMPLOYEE/EMPLOYMENT RESTRICTIONS – THE CONTRACTOR:
THE CONTRACTOR, (hereinafter referred to as “SERVICE PROVIDER”) agrees, as a condition of accepting this contract with the City of Peoria, that, for a period of one (1) year following completion of this contract, it shall be prohibited from hiring, directly or indirectly, any City employee or official who was involved, directly or indirectly in: (1) the selection and/or recommendation to select the SERVICE PROVIDER for performance of this contract; (2) coordinating the efforts of the SERVICE PROVIDER in the consummation or completion of this contract; or (3) monitoring or determining the performance of the SERVICE PROVIDER. The SERVICE PROVIDER further acknowledges and agrees that, upon the City’s determination that a violation of this provision has occurred, the penalty imposed, at the sole discretion of the City, may include one or more of the following: (1) cancellation of any other contract(s) between the City of Peoria and the SERVICE PROVIDER; (2) disqualification of the SERVICE PROVIDER from bidding or being awarded future contracts with the City of Peoria for a period of two [2] years; and/or (3) payment of liquidated damages to the City of Peoria in the amount of TWENTY FIVE THOUSAND DOLLARS (\$25,000.00). *This does not apply to any City Employee involved in the 2011-12 reduction in force; nor does it apply to parties taking the Early Retirement Incentive offered by the City from November 1, 2011 through November 1, 2012.*
21. To be awarded a contract all Suppliers, Vendors, Contractors to the City of Peoria, must be registered in the City of Peoria’s Contract Compliance Program and have a current EEO Certification Number. This program is unrelated to any State and Federal program.

The number is secured by submitting to the Equal Opportunity Manager a completed Employer Report Form CC-1, a Fifty-dollar (\$50.00) processing fee and a copy of your company’s sexual harassment policy statement, if you are a first time applicant. Companies renewing their number do not have to submit a copy of their sexual harassment policy statement. The form may be obtained from the City’s website at www.peoriagov.org/equal-opportunity/ by clicking on the link. You can also request a copy by e-mail or calling:

Equal Opportunity Manager
eeo@peoriagov.org
(309) 494-8530

The Fifty-dollar (\$50.00) processing fee can be paid by check, payable to the City of Peoria, or online through the State of Illinois E-Pay process. To pay online go to www.illinoisepay.com and follow the instructions. The only exception to payment of the processing fee is neighborhood associations.

Although all vendors are encouraged to obtain an EEO Certification Number, you do not need a number to respond to a bid. The number is only required prior to the award of a contract.

EEO CERTIFICATION (Check one):

We are renewing or applying for an EEO Certification Number. Employer Report Form CC-1 is completed and enclosed.

We have a current EEO Certification Number on file with the City.
Our EEO Certification Number: _____

22. The City of Peoria can increase or decrease this contract by 25% to meet budgetary needs.
23. The undersigned submits herewith this schedule of prices covering the work to be performed under this contract

NORTH WISCONSIN AVENUE ORNAMENTAL LIGHTING

(McCLURE AVENUE TO EAST REPUBLIC STREET)

SCHEDULE OF PRICES

<u>Item</u>	<u>Quantity</u>	<u>Unit</u>	<u>Unit Price</u>	<u>Extension</u>
Traffic Control and Protection	1	LSum	_____	_____
Removal and Disposal of Unsuitable Material	30	C.Y.	_____	_____
Portland Cement Concrete Sidewalk	100	S.F.	_____	_____
Concrete Handhole	2	Ea.	_____	_____
Conduit (2")	2860	Ft.	_____	_____
Light Pole Foundation	25	Ea.	_____	_____
Light Pole, Decorative	25	Ea.	_____	_____
ELCBL, In Conduit, 600V XLP, 1/c, No. 6, Green	3550	Ft.	_____	_____
ELCBL, In Conduit, 600V XLP, 1/c, No. 6, Black	7100	Ft.	_____	_____

TOTAL BID \$ _____

Continued on next page

SIGNATURE PAGE

(If an individual) Signature of Bidder _____

Business Address _____

(If a partnership) Firm Name _____

Signed by _____

President

Business Address _____

Insert Names _____
and Addresses _____
of all partners: _____

(If a corporation) Corporate Name _____

Signed by _____

Business Address _____

Insert Names
of Officers:

President

Secretary

Treasurer

Attest: _____
Secretary

PROPOSAL BID BOND



RETURN WITH BID

Route _____
 Municipality City of Peoria
 Rd. Dist./Twnshp _____
 County Peoria
 Section _____

WE _____ as PRINCIPAL, an _____ as SURETY,

are held and firmly bound unto THE CITY OF PEORIA (hereafter referred to as "LA") in the penal sum of 5% of the total bid price, or for the amount specified in Article 102.09 of the "Standard Specifications for Road and Bridge Construction" in effect on the date of invitation for bids. We bind ourselves, our heirs, executors, administrators, successors, and assigns, jointly to pay to the LA this sum under the conditions of this instrument.

WHEREAS THE CONDITION OF THE FOREGOING OBLIGATION IS SUCH that, the said PRINCIPAL is submitting a written proposal to the LA acting through its awarding authority for the construction of the work designated as the above section.

THEREFORE if the proposal is accepted and a contract awarded to the PRINCIPAL by the LA for the above designated section and the PRINCIPAL shall within fifteen (15) days after award enter into a formal contract, furnish surety guaranteeing the faithful performance of the work, and furnish evidence of the required insurance coverage, all as provided in the "Standard Specifications for Road and Bridge Construction" and applicable Supplemental Specifications, then this obligation shall become void; otherwise it shall remain in full force and effect.

IN THE EVENT the LA determines the PRINCIPAL has failed to enter into a formal contract in compliance with any requirements set forth in the preceding paragraph, then the LA acting through its awarding authority shall immediately be entitled to recover the full penal sum set out above, together with all court costs, all attorney fees, and any other expense of recovery.

IN TESTIMONY WHEREOF, the said PRINCIPAL and the said SURETY have caused this instrument to be signed by their respective officers this _____ day of _____ A.D. _____

Principal

 (Company Name) _____ (Company Name)
 By: _____ By: _____
 (Signature and Title) (Signature and Title)

(If PRINCIPAL is a joint venture of two or more contractors, the company names, and authorized signatures of each contractor must be affixed.)

Surety

 (Name of Surety) By: _____
 (Signature of Attorney-in-Fact)

STATE OF ILLINOIS,
 COUNTY OF _____

I, _____, a Notary Public in and for said county,
 do hereby certify that _____

(Insert names of individuals signing on behalf of PRINCIPAL & SURETY)

who are each personally known to me to be the same persons whose names are subscribed to the foregoing instrument on behalf of PRINCIPAL and SURETY, appeared before me this day in person and acknowledged respectively, that they signed and delivered said instruments as their free and voluntary act for the uses and purposes therein set forth.

Given under my hand and notarial seal this _____ day of _____ A.D. _____

NOTICE

- Improper execution of this form (i.e. missing signatures or seals or incomplete certification) will result in bid being declared irregular.
- If bid bond is used in lieu of proposal guaranty check, it must be on this form and must be submitted with bid

My commission expires _____

 (Notary Public)



CITY OF PEORIA SUB-CONTRACTOR UTILIZATION STATEMENT

Section I (select all that apply)

___ MBE/WBE Subcontractor(s) will be utilized on this project

___ Non MBE/WBE Subcontractor(s) will be utilized on this project

Section II: Prime Contractor

Project

Name: _____

Name: _____

Address: _____

Total Contract Value: _____

Phone: _____

Contact Person: _____

Email: _____

Ownership Status: MBE ___ WBE ___ M/WBE ___ Non-M/WBE ___

Section III: Selected Subcontractors

Subcontractor Name	MBE, WBE or Non M/WBE	Amount	% of Total Contract	Scope of Work
TOTALS				

**If more than seven firms are utilized, please copy the form and attach the additional information.*

Section IV: Subcontractors that submitted bids but were not selected (M/WBE Only)

Subcontractor Name	Scope of Work Bid	Denial Reason

**If more than seven firms submitted quotes, please copy the form and attach the additional information.*

-----Continues on next page-----

For Office Use Only
Reviewed by: _____

Section V: Subcontractors Contacted (M/WBE Only)

Subcontractor Name	Method of Contact	Contact Outcome

**If more than six firms were contacted, please copy the form and attach the additional information*

Section IV

The City of Peoria is committed to promoting equal opportunity and has established the following subcontractor utilization goals for city funded construction projects: 10% MBE and 5% WBE. Prime Contractors have an obligation to make a good faith effort to advance the city's commitment to increase diversity among the firms working on city construction projects.

This form must be completed and submitted with bid proposals. ALL subcontractors intended for use on this project shall be listed in the Section III above; along with the total amount to be paid to the subcontractors; percentage of total contract; and scope of work. If for whatever reason the prime contractor has to utilize a subcontractor not listed above, they must submit a Notification of Change in Participation.

The undersigned certifies that the information included herein is true and correct; the subcontractors listed above have agreed to perform the scope of work described. The undersigned further certifies that it has no controlling, dominating or conflict of interest in any of the listed subcontractors.

Signature of Prime Contractor

Date

For Office Use Only
Reviewed by: _____

Org.: May 2008
Revised: Feb. 2011



**CITY OF PEORIA
M/WBE PARTICIPATION WAIVER REQUEST**

PRIME CONTRACTOR

Name: _____
Address: _____
Phone: _____
Contact Person: _____

PROJECT

Name: _____

We hereby request to waive all of the MBE and WBE participation goals on the above named project and self-perform all work for the following reason(s). The firm further affirms that the stated reasons and documents provided are true and correct and not misleading: **(CHECK ALL THAT APPLY. SPECIFIC SUPPORTING DOCUMENTATION MUST BE SUBMITTED WHERE INDICATED.)**

- 1. No MBEs/WBEs responded to our invitation to bid. _____
- 2. No subcontracting opportunities exist. (Attach explanation) _____
- 3. The award of subcontract(s) is impracticable. (Attach explanation) _____

SIGNED: _____
(Company Official)

DATE: _____

FOR OFFICE USE ONLY

APPROVED

DISAPPROVED

REVIEWED BY _____

DATE _____

PART 2- GENERAL CONDITIONS

DESCRIPTION OF WORK

The proposed improvement consists of the installation of twenty-five (25) new decorative street lights and services and other incidental and collateral work as shown on the plans and as specified herein along North Wisconsin Avenue from McClure Avenue southerly to East Republic Avenue. This work shall be done in accordance with the Standard Specifications for Road and Bridge Construction adopted April 1, 2016, at locations designated in this document or as directed by the City. Necessary adjustments, incidentals and appurtenant items shall be constructed as directed by the City.

CONTACT INFORMATION

The City's Project Engineer will be Stephen Letsky, P.E., at 309-494-8800. A resident engineer (RE) will coordinate field operations. Contact the RE for general construction questions and information.

TIME OF THE ESSENCE

Time is an essential element of the Contract and the City will monitor the Contractor's progress towards completion. The Contractor shall adequately staff the project so that the entire project can be completed in a timely manner.

FAILURE TO COMPLETE WORK ON TIME

Should the Contractor fail to complete the work by **November 23, 2016**, the Contractor shall be liable to the City of Peoria at a rate of \$750.00 per day for every day worked over the contract time to cover all costs incurred for engineering, inspection and other expenses incurred by the City of Peoria by reason of the Contractor's failure to complete the work within the specified time, and such amount shall be deducted from the monies due the Contractor, not as a penalty, but as damages sustained.

PROSECUTION AND PROGRESS OF WORK

Special attention is called to Section 108 of the "Standard Specifications for Road and Bridge Construction," and specifically to Article 108.03, which states that the Contractor shall notify the City at least twenty-four (24) hours in advance of either discontinuing or resuming operations.

If a City representative is not on the job and notification as required has been given, the Contractor in charge of the work shall immediately notify the City, that work has been resumed and request that the City representative in charge of the work be notified.

Work performed without proper notification to the City as indicated herein may be rejected by the City and no compensation will be made for said work. In addition, the Contractor may be required to remove the item of construction at its own expense and replace the item of construction in accordance with the specifications.

DEFINITION OF TERMS

Section 101 of the Standard Specifications shall be revised as follows:

Article 101.14 Department. The City of Peoria or its Representative.

Article 101.16 Engineer. The designated employee or Owner's Representative.

The Engineer nor the Owner's Representative will not be responsible for construction means, methods, techniques, sequences, or procedures, or for safety precautions and programs.

Article 101.19 Inspector. The Owner's Representative assigned to make detailed observations on any or all portions of the work or material therefore. This activity is not to be interpreted as an inspection service, a construction supervision service, or a guaranteeing of the Contractor's performance. The Inspector will not be responsible for construction means, methods, techniques, sequences, or procedures, or for safety precautions and programs. The Inspector will not be responsible for the Contractor's obligation to carry out the work in accordance with the Contract Documents. Observation of EEO diversity in the field will be noted.

RESPONSIBILITY FOR DAMAGE CLAIMS

The Contractor shall indemnify and save harmless the CITY OF PEORIA, its officers and employees; the Owner's Representative, its officers and employees, against all loss, damage or expense that it or they may sustain as a result of any suits, actions, or claims of any character brought on account of injury to or death of any person or persons, including all persons performing any work under this contract, which may arise in any way (except for a negligent act of the City of Peoria, its officers or employees or the Owner's Representative, its officers or employees) in connection with the work to be performed under this contract, including but not limited to, suits, actions or claims arising under "An Act providing for the protection and safety of persons in and about the construction, repairing, alteration or removal of building, bridges, viaducts, and other structures, and to provide for the enforcement thereof," approved June 3, 1907, (740 ILCS 150/1), as amended: the Contractor shall also indemnify and save harmless the CITY OF PEORIA, its officers and employees; and the Owner's Representative, its officers and employees, from all suits, actions, or claims of any character brought because of any injuries or damages received or sustained by any person, persons, or property, on account of, or in consequence of, any neglect by Contractor or a Subcontractor in safeguarding the work; or through use of unacceptable materials in constructing the work; or because of any act or omission, neglect, or misconduct of said Contractor; or because of any claims or amounts recovered for any infringements of patent, trademark, or copyright, or from any claims or amounts arising or recovered under the "Workers Compensation Act," or any other law, ordinance, order, or decree, and so much of the money due the said Contractor under and by virtue of this contract as shall be considered necessary by the Department for such purposes, may be retained for the use of the ENGINEERING DIVISION; or, in case no money is due, the surety shall be held until such suits, actions, or claims have been settled and suitable evidence to that effect furnished to the Department.

QUALIFICATION OF CONTRACTORS

Contractors shall be qualified before plans and proposal documents will be provided for bidding. In general, contractors qualified by the State of Illinois' Department of Transportation to perform the work indicated in the proposal will be acceptable to the City of Peoria, Engineering Division; but, the City Engineer reserves the right to refuse to accept a bid from a State-qualified contractor and will state the reasons, in writing, for said refusal if requested by the contractor.

Contractors who have done similar work and improvements of similar size for the City in the past normally are qualified by their past performances.

Contractors not qualified as indicated above shall be required to submit a listing of jobs of a similar nature with an indication of the dollar value of said jobs and the person or company for whom the work was performed so that a check of the quality of the work can be made, as well as the performance and financial ability of the Contractor. The City Engineer will approve or disapprove the Contractor, and the decision shall be final. If desired by the Contractor, the City Engineer will provide the reasons for disapproving any Contractor from bidding on the proposed improvement.

CONTRACTOR'S INSURANCE

The Contractor shall not commence work under this project until the contractor has obtained all insurance required under this paragraph and such insurance has been approved by the City of Peoria, nor shall the Contractor allow any Subcontractor to commence work on the subcontract until all similar insurance required of the Subcontractor has been so obtained and approved by the City of Peoria.

The Contractor shall require Subcontractors, if any, not protected under the Contractor's insurance policies as an additional insured to take out and maintain insurance of such nature in amounts not less than that required of the principal Contractor, excluding Umbrella Coverage and Owner's Protective Liability and Property Damage Insurance, and any and all insurance obtained by any Subcontractor or Subcontractors shall be approved by the City of Peoria.

All policies shall contain provisions to the effect that in the event of payment of any loss or damage the insurers will have no rights of recovery against any of the insured or additional insured there under.

COMPENSATION INSURANCE

The Contractor shall take out and maintain during the life of this project Worker's Compensation Insurance for all of the employees employed at the site of the project and, in case any work is sublet, the Contractor shall require the Subcontractor similarly to provide Worker's Compensation Insurance for all of the latter's employees unless such employees are covered by the protection afforded by the Contractor, and any such insurance obtained by any subcontractor or subcontractors shall be approved by the City of Peoria. In case any class of employees engaged in hazardous work at the site of the project is not protected under the Worker's Compensation statute, the Contractor shall provide, and shall cause each Subcontractor to provide adequate insurance coverage for the protection of the employees not otherwise protected, such as accident insurance, and any such insurance shall be approved by the City of Peoria.

PUBLIC LIABILITY AND PROPERTY DAMAGE INSURANCE

The Contractor shall take out and maintain during the life of the project such General Liability, Public Liability and Property Damage Insurance as shall protect the contractor and any Subcontractor performing work covered by this project, from claims for damages for personal injury, including accidental death, as well as from claims for property damages, which may arise from operations under this project, whether such operations be by himself or by any Subcontractors or by anyone directly or indirectly employed by either of them and the amounts of such insurance shall be as follows:

Commercial General Liability Insurance that provides Property Damage and/or Bodily Injury in an amount not less than \$1,000,000 per occurrence and \$2,000,000 aggregate.

OWNER'S PROTECTIVE LIABILITY AND PROPERTY DAMAGE INSURANCE

The Contractor shall obtain Owner's Protective Liability and Property Damage Insurance in an amount not less than \$1,000,000 per occurrence and \$2,000,000 aggregate. If endorsements to the above public liability and property damage insurance policies cannot be made, then separate policies providing such protection must be furnished by the Contractor.

AUTOMOBILE INSURANCE

The Contractor shall take out and maintain during the life of the project such automobile insurance covering all owned and non-owned vehicles as shall project the contractor an any Subcontractor performing work covered by this project, from claims for damages in an amount not less than \$1,000,000 Combined Bodily Injury and Property Damage.

UMBRELLA COVERAGE

The Contractor shall take out and maintain during the life of the project such Umbrella or Excess Liability coverage as shall protect the contractor and any Subcontractor performing work covered by this project, from claims for damages in an amount not less than \$2,000,000 per occurrence and \$5,000,000 annual aggregate.

ADDITIONAL INSURED ENDORSEMENT

All Liability insurance policies shall name the City of Peoria its officers, directors, employees, agents, Representatives, subsidiaries, successors and assigns; and the Owner's Representative its officers, directors, employees, agents, Representatives, subsidiaries, successors, and assigns, as additional insured, shall be primary to any other insurance carried by the City of Peoria or the Owner's Representative, and shall provide coverage consistent with ISO CG 20 26, and shall maintain the required coverages, naming the City of Peoria and the Owner's Representative as additional insured, for a period of not less than three years from the date the City of Peoria and Contractor execute an Agreement to Final Quantities.

PROOF OF CARRIAGE OF INSURANCE

The Contractor and all Subcontractors shall furnish the City of Peoria with satisfactory proof of insurance coverage. This shall include an A.M. Best "A" rating before the project begins. If coverage is cancelled or the carrier's rating falls below A.M. Best "A" rated, the City of Peoria shall be notified in writing.

Certificates of insurance are required. The Certificate must state the following "The City of Peoria, its officers, directors, employees, agents, and Representative; and the Owner's Representative ,its officers, directors, employees, agents, and Representative" are named as Additional Insured on a primary basis for liability arising out of the Contractor's operations."

Upon request the Contractor must provide copies of the policies and endorsements, failure to provide the required certificates of insurance shall not operate to invalidate the insurance requirements under this Contract.

SUBSTANCE ABUSE PREVENTION PROGRAM

Before the Contractor and any Subcontractor commences work, the Contractor and any Subcontractor shall have in place a written Substance Abuse Prevention Program for the prevention of substance abuse among its employees which meets or exceeds the requirements in P.A. 95-0635 or shall have a collective bargaining agreement in effect dealing with the subject matter of P.A. 95-0635.

The Contractor and any Subcontractor shall file with a public body: a copy of the substance abuse prevention program along with a cover letter certifying that their program meets the requirements of the Act, or a letter certifying that the Contractor or a Subcontractor has a collective bargaining agreement in effect dealing with the subject matter of the Act.

EXISTING UNDERGROUND FACILITIES

The City of Peoria assumes no responsibility for the presence, specific size or location of underground distribution systems of the several public utility corporations. No responsibility for the protection of said underground systems will be assumed by the City of Peoria unless such protection is incidental to the protection of the municipally-owned property of the City of Peoria. If such protection is found to be necessary to water mains, gas mains, steam mains, underground electrical distribution systems, underground telephone circuit systems or any other underground systems of non-municipal ownership, the cost of same, in whole or in part, is disclaimed by the City of Peoria.

COOPERATION WITH UTILITY COMPANIES

It is understood and agreed that the Contractor has considered, in their bid, all the permanent and temporary utility appurtenances in their present or relocated positions and that no additional compensation will be allowed for any delays, inconvenience or damage sustained by the contractor due to any interference from the said utility appurtenances or the operations of moving them.

All telephone, cableway, gas, water and wire lines, within the limits of the proposed construction owned by various utility companies, are to be moved by the owners of the particular utility involved at the owner's expense.

NOTIFICATION OF UTILITIES PRIOR TO CONSTRUCTION

All utility companies must be notified by the Contractor, in writing, at least one (1) week in advance prior to starting construction on the City-wide program so that they will have adequate time to locate and mark their utility locations in the field and twenty-four (24) hours prior to commencing actual construction work. All utility companies must be notified so that they may have personnel on the job site to assist in locating their utility lines and avoid damage to their utilities. Specifically, Ameren ILLINOIS, Comcast Communications, AT&T, McLeod Communications and the Illinois-American Water Co., have requested that they be notified prior to the start of construction. A copy of the letter notifying the utility companies of the Contractor's intention to start work on the City-wide program must be received by the City before the Contractor will be permitted to start construction.

J.U.L.I.E. SYSTEM

The J.U.L.I.E. (Joint Utility Locating Information for Excavators) must be notified prior to starting

construction, so that the respective utilities may have adequate time to locate and mark their underground facilities. Phone: 1-800-892-0123 or 811.

NOTIFICATION OF THE PUBLIC

The Contractor shall notify the property owners along the streets that will be under construction in writing a minimum of one week in advance of the start of construction. The Contractor shall notify the property owners in writing a minimum of three working days in advance of the removal of any driveway or alley. Submit the draft letters at the preconstruction meeting. The City must approve the letter prior to distribution to the public. Please allow at a minimum one week for City review. Coordinate with the City on when the letters will be distributed. The typed notification letter shall include at a minimum: the work schedule, no parking restrictions, property access information, and the contractor contact person's name, local phone number, and email address. The notification shall be of the door hanger type which secures to the door handle of each dwelling. Unsecured notices will not be allowed. The contractor shall also place the notice on the windshield of any parked cars on the street.

The City will issue press releases based on the information provided by the contractor. Press releases will be issued 1-2 days in advance of the work. The Contractor shall provide press release information to the City a minimum of 2 days in advance of the work.

It is the responsibility of the Contractor to post "NO PARKING" signs at least one day in advance of work being started. If there are any vehicles that have to be towed the Contractor will first contact the City Police Dispatcher (309-494-8021) to get the name and address of the owner. If the owner lives in the area the Contractor will try to contact the owner directly and request that they move their vehicle. If the Contractor is unable to contact the owner to move the vehicle they will then contact the Chuck's Towing at 309-637-0425 and arrange to have a tow truck move the vehicle to the nearest out of the way location. The tow truck will be paid for by the City of Peoria. The Contractor will keep a log of all vehicles moved that lists the date, time and number they tried to contact the owner, the date and time the vehicle is moved, make and model of vehicle, license plate number, name of towing company, vehicle owner's name, the location the vehicle is towed from and the location the vehicle is towed.

CERTIFIED PAYROLL REQUIREMENTS

Contractors and subcontractors on public works projects must submit certified payroll records on a weekly basis via EPrismSoft to the public body in charge of the construction project, along with a statement affirming that such records are true and accurate, that the wages paid to each worker are not less than the required prevailing rate, and that the Contractor is aware that filing records he or she knows to be false is a Class B Misdemeanor. The Certified Payroll Records must include, for every worker employed on the public works project, the name, address, telephone number, social security number, job classification, hourly wages paid in each pay period, number of hours worked each day, and starting and ending time of work each day. Certified payrolls are to be submitted weekly on EPrismSoft, per the EEO guidelines outlined in Section VII of the Good Faith Efforts Requirements, herein. Copies of the certified payrolls as submitted to EPrismSoft should be submitted with each payment application for review by the City.

PREVAILING WAGE PROVISION

This contract is for the performance of "public works" as that term is defined by 820 ILCS 130/2. Contractor shall not pay less than the prevailing rates of wages to all laborers, workmen, and mechanics performing work under this contract, and shall comply with the requirements of the Illinois Wages of Employees on Public Works Act (820 ILCS 130/1-12).

These prevailing rates of wages are included in this contract. If the Department of Labor revises the prevailing rate of hourly wages to be paid by the public body, the revised rate as provided by the public body shall apply to this contract. It shall be the Contractor's responsibility to monitor the prevailing wages and adjust the payroll accordingly as soon as any rates are revised. The prevailing rates of wages are revised on a monthly basis and can be found on the Illinois Department of Labor's website. <http://www.illinois.gov/idol/Laws-Rules/CONMED/Pages/prevailing-wage-rates.aspx>

Peoria County Prevailing Wage for July 2015

(See explanation of column headings at bottom of wages)

Trade Name	RG	TYP	C	Base	FRMAN	M-F>8	OSA	OSH	H/W	Pensn	Vac	Trng
ASBESTOS ABT-GEN		BLD		26.700	28.200	1.5	1.5	2.0	7.700	16.21	0.000	0.800
ASBESTOS ABT-GEN		HWY		29.910	31.410	1.5	1.5	2.0	7.700	17.47	0.000	0.800
ASBESTOS ABT-MEC		BLD		32.510	35.010	1.5	1.5	2.0	11.47	10.96	0.000	0.720
BOILERMAKER		BLD		38.000	41.000	2.0	2.0	2.0	7.070	15.99	0.000	0.400
BRICK MASON		BLD		32.380	33.880	1.5	1.5	2.0	8.600	9.870	0.000	0.590
Trade Name	RG	TYP	C	Base	FRMAN	M-F>8	OSA	OSH	H/W	Pensn	Vac	Trng
CARPENTER		BLD		30.880	33.130	1.5	1.5	2.0	8.000	15.71	0.000	0.520
CARPENTER		HWY		32.700	34.950	1.5	1.5	2.0	8.000	15.81	0.000	0.520
CEMENT MASON		BLD		28.050	29.800	1.5	1.5	2.0	7.500	15.65	0.000	0.500
CEMENT MASON		HWY		29.280	30.780	1.5	1.5	2.0	7.500	16.02	0.000	0.500
CERAMIC TILE FNSHER		BLD		29.890	0.000	1.5	1.5	2.0	8.600	10.05	0.000	0.580
ELECTRIC PWR EQMT OP		ALL		38.300	45.290	1.5	1.5	2.0	6.150	10.73	0.000	0.380
ELECTRIC PWR GRNDMAN		ALL		26.280	45.290	1.5	1.5	2.0	5.790	7.360	0.000	0.260
ELECTRIC PWR LINEMAN		ALL		42.540	45.290	1.5	1.5	2.0	6.280	11.92	0.000	0.430
ELECTRIC PWR TRK DRV		ALL		27.560	45.290	1.5	1.5	2.0	5.830	7.720	0.000	0.280
ELECTRICIAN		ALL		34.820	37.320	1.5	1.5	2.0	6.500	11.68	0.000	0.800
ELECTRICIAN		BLD		34.820	37.320	1.5	1.5	2.0	6.100	11.43	0.000	0.400
ELECTRONIC SYS TECH		BLD		28.250	30.250	1.5	1.5	2.0	6.350	10.54	0.000	0.400
ELEVATOR CONSTRUCTOR		BLD		41.690	46.900	2.0	2.0	2.0	13.57	14.21	3.340	0.600
GLAZIER		BLD		31.870	33.870	1.5	1.5	1.5	10.25	7.700	0.000	1.250
HT/FROST INSULATOR		BLD		43.350	45.850	1.5	1.5	2.0	11.47	12.36	0.000	0.720
IRON WORKER		BLD		32.190	34.090	0.0	0.0	0.0	9.490	13.91	0.000	0.000
IRON WORKER		HWY		35.980	37.980	0.0	0.0	0.0	9.490	13.91	0.000	0.000
LABORER		BLD		25.700	27.200	1.5	1.5	2.0	7.700	16.21	0.000	0.800
LABORER		HWY		29.160	30.660	1.5	1.5	2.0	7.700	17.47	0.000	0.800
LABORER, SKILLED		BLD		26.100	27.600	1.5	1.5	2.0	7.700	16.21	0.000	0.800
LABORER, SKILLED		HWY		29.460	30.960	1.5	1.5	2.0	7.700	17.47	0.000	0.800
LATHER		BLD		30.880	33.130	1.5	1.5	2.0	8.000	15.71	0.000	0.520
MACHINERY MOVER		HWY		35.980	37.980	0.0	0.0	0.0	9.490	13.91	0.000	0.000
MACHINIST		BLD		45.350	47.850	1.5	1.5	2.0	7.260	8.950	1.850	0.000
MARBLE FINISHERS		BLD		29.890	0.000	1.5	1.5	2.0	8.600	10.05	0.000	0.580
MARBLE MASON		BLD		31.650	32.900	1.5	1.5	2.0	8.600	10.05	0.000	0.580
MILLWRIGHT		BLD		31.060	33.310	1.5	1.5	2.0	8.000	15.87	0.000	0.520
MILLWRIGHT		HWY		33.060	35.310	1.5	1.5	2.0	8.000	15.95	0.000	0.520
OPERATING ENGINEER		BLD	1	37.050	40.050	1.5	1.5	2.0	7.000	17.48	0.000	3.000

Monday payable at the appropriate overtime rate for holiday pay. Common practice in a given local may alter certain days of celebration. If in doubt, please check with IDOL.

Oil and chip resealing (O&C) means the application of road oils and liquid asphalt to coat an existing road surface, followed by application of aggregate chips or gravel to coated surface, and subsequent rolling of material to seal the surface.

EXPLANATION OF CLASSES

ASBESTOS - GENERAL - removal of asbestos material/mold and hazardous materials from any place in a building, including mechanical systems where those mechanical systems are to be removed. This includes the removal of asbestos materials/mold and hazardous materials from ductwork or pipes in a building when the building is to be demolished at the time or at some close future date.

ASBESTOS - MECHANICAL - removal of asbestos material from mechanical systems, such as pipes, ducts, and boilers, where the mechanical systems are to remain.

CERAMIC TILE FINISHER, MARBLE FINISHER, TERRAZZO FINISHER

Assisting, helping or supporting the tile, marble and terrazzo mechanic by performing their historic and traditional work assignments required to complete the proper installation of the work covered by said crafts. The term "Ceramic" is used for naming the classification only and is in no way a limitation of the product handled. Ceramic takes into consideration most hard tiles.

ELECTRONIC SYSTEMS TECHNICIAN

Installation, service and maintenance of low-voltage systems which utilizes the transmission and/or transference of voice, sound, vision, or digital for commercial, education, security and entertainment purposes for the following: TV monitoring and surveillance, background/foreground music, intercom and telephone interconnect, field programming, inventory control systems, microwave transmission, multi-media, multiplex, radio page, school, intercom and sound burglar alarms and low voltage master clock systems.

Excluded from this classification are energy management systems, life safety systems, supervisory controls and data acquisition systems not intrinsic with the above listed systems, fire alarm systems, nurse call systems and raceways exceeding fifteen feet in length.

LABORER, SKILLED - BUILDING

The skilled laborer building (BLD) classification shall encompass the following types of work, irrespective of the site of the work: cutting & acetylene torch, gunnite nozzlemen, gunnite pump men & pots, kettlemen & carriers of men handling hot stuff, sandblaster nozzle men, sandblasting pump men & pots, setting up and using concrete burning bars, wood block setters, underpinning & shoring of existing buildings, and the unload-ing and handling of all material coated with creosote.

LABORER, SKILLED - HIGHWAY

The skilled laborer heavy & highway (HWY) classification shall encompass the following types of work, irrespective of the site of the work: jackhammer & drill operator, gunite pump & pot man, puddlers, vibrator men, wire fabric placer, sandblast pump & pot man, strike off concrete, unloading,

handling & carrying of all creosoted piles, ties or timber, concrete burning bars, power wheelbarrows or buggies, asphalt raker, brickset-ters, cutting torchman (electric & acetylene), men setting lines to level forms, form setters, gunite nozzle man & sandblasting nozzle man, power man, and rip-rapping by hand.

SURVEY WORKER - Operated survey equipment including data collectors, G.P.S. and robotic instruments, as well as conventional levels and transits.

TRUCK DRIVER - BUILDING, HEAVY AND HIGHWAY CONSTRUCTION

Class 1. Drivers on 2 axle trucks hauling less than 9 ton. Air compressor and welding machines and brooms, including those pulled by separate units, truck driver helpers, warehouse employees, mechanic helpers, greasers and tiremen, pickup trucks when hauling materials, tools, or workers to and from and on-the-job site, and fork lifts up to 6,000 lb. capacity.

Class 2. Two or three axle trucks hauling more than 9 ton but hauling less than 16 ton. A-frame winch trucks, hydrolift trucks, vactor trucks or similar equipment when used for transportation purposes. Fork lifts over 6,000 lb. capacity, winch trucks, four axle combination units, and ticket writers.

Class 3. Two, three or four axle trucks hauling 16 ton or more. Drivers on water pulls, articulated dump trucks, mechanics and working forepersons, and dispatchers. Five axle or more combination units.

Class 4. Low Boy and Oil Distributors.

Class 5. Drivers who require special protective clothing while employed on hazardous waste work.

TRUCK DRIVER - OIL AND CHIP RESEALING ONLY.

This shall encompass laborers, workers and mechanics who drive contractor or subcontractor owned, leased, or hired pickup, dump, service, or oil distributor trucks. The work includes transporting materials and equipment (including but not limited to, oils, aggregate supplies, parts, machinery and tools) to or from the job site; distributing oil or liquid asphalt and aggregate; stock piling material when in connection with the actual oil and chip contract. The Truck Driver (Oil & Chip Resealing) wage classification does not include supplier delivered materials.

OPERATING ENGINEERS - BUILDING

Class 1. Cranes; Overhead Cranes; Gradall; All Cherry Pickers; Mechanics; Central Concrete Mixing Plant Operator; Road Pavers (27E - Dual Drum - Tri Batchers); Blacktop Plant Operators and Plant Engineers; 3 Drum Hoist; Derricks; Hydro Cranes; Shovels; Skimmer Scoops; Koehring Scooper; Drag Lines; Backhoe; Derrick Boats; Pile Drivers and Skid Rigs; Clamshells; Locomotive Cranes; Dredge (all types) Motor Patrol; Power Blades - Dumore - Elevating and similar types; Tower Cranes (Crawler-Mobile) and Stationary; Crane-type Backfiller; Drott Yumbo and similar types considered as Cranes; Caisson Rigs; Dozer; Tournadozer; Work Boats; Ross Carrier; Helicopter; Tournapulls - all and similar types; Scoops (all sizes); Pushcats; Endloaders (all types); Asphalt Surfacing Machine; Slip Form Paver; Rock Crusher; Heavy Equipment Greaser; CMI, CMI Belt Placer, Auto Grade & 3 Track and similar types; Side Booms; Multiple Unit Earth Movers;

Creter Crane; Trench Machine; Pump-crete-Belt Crete-Squeeze Cretes-Screw-type Pumps and Gypsum; Bulker & Pump - Operator will clean; Formless Finishing Machine; Flaherty Spreader or similar types; Screed Man on Laydown Machine; Wheel Tractors industrial or Farm-type w/Dozer-Hoe-Endloader or other attachments); F.W.D. & Similar Types; Vermeer Concrete Saw.

Class 2. Dinkeys; Power Launches; PH One-pass Soil Cement Machine (and similar types); Pugmill with Pump; Backfillers; Euclid Loader; Forklifts; Jeeps w/Ditching Machine or other attachments; Tuneluger; Automatic Cement and Gravel Batching Plants; Mobile Drills (Soil Testing) and similar types; Gurries and Similar Types; (1) and (2) Drum Hoists (Buck Hoist and Similar Types); Chicago Boom; Boring Machine & Pipe Jacking Machine; Hydro Boom; Dewatering System; Straw Blower; Hydro Seeder; Assistant Heavy Equipment Greaser on Spread; Tractors (Track type) without Power Unit pulling Rollers; Rollers on Asphalt -- Brick Macadem; Concrete Breakers; Concrete Spreaders; Mule Pulling Rollers; Center Stripper; Cement Finishing Machines & CMI Texture & Reel Curing Machines; Cement Finishing Machine; Barber Green or similar loaders; Vibro Tamper (All similar types) Self-propelled; Winch or Boom Truck; Mechanical Bull Floats; Mixers over 3 Bag to 27E; Tractor pulling Power Blade or Elevating Grader; Porter Rex Rail; Clary Screed; Truck Type Hoptoe Oilers; Fireman; Spray Machine on Paving; Curb Machines; Truck Crane Oilers; Oil Distributor; Truck-Mounted Saws.

Class 3. Air Compressor; Power Subgrader; Straight Tractor; Trac Air without attachments; Herman Nelson Heater, Dravo, Warner, Silent Glo, and similar types; Roller: Five (5) Ton and under on Earth or Gravel; Form Grader; Crawler Crane & Skid Rig Oilers; Freight Elevators - permanently installed; Pump; Light Plant; Generator; Conveyor (1) or (2) - Operator will clean; Welding Machine; Mixer (3) Bag and Under (Standard Capacity with skip); Bulk Cement Plant; Oiler on Central Concrete Mixing Plant.

OPERATING ENGINEERS - HEAVY AND HIGHWAY CONSTRUCTION

CLASS 1. Cranes; Hydro Cranes; Shovels; Crane Type Backfiller; Tower, Mobile, Crawler, & Stationary Cranes; Derricks; Hoists (3 Drum); Draglines; Drott Yumbo & Similar Types considered as Cranes; 360 Degree Swing Excavator (Shears, Grapples, Movacs, etc.); Back Hoe; Derrick Boats; Pile Driver and Skid Rigs; Clam Shell; Locomotive - Cranes; Road Pavers - Single Drum - Dual Drum - Tri Batcher; Motor Patrols & Power Blades - Dumore - Elevating & Similar Types; Mechanics; Central Concrete Mixing Plant Operator; Asphalt Batch Plant Operators and Plant Engineers; Gradall; Caisson Rigs; Skimmer Scoop - Koering Scooper; Dredges (all types); Hoptoe; All Cherry Pickers; Work Boat; Ross Carrier; Helicopter; Dozer; Tornadozer; Tournapulls - all and similar types; Operation of Concrete and all Recycle Machines; Multiple Unit Earth Movers; Scoops (all sizes); Pushcats; Endloaders (all types); Asphalt Surfacing Machine; Slip Form Paver; Rock Crusher; Operation of Material Crusher, Screening Plants, and Tunnel Boring Machine; Heavy Equipment Greaser (top greaser on spread); CMI, Auto Grade, CMI Belt Placer & 3 Track and Similar Types; Side Booms; Asphalt Heater & Planer Combination (used to plane streets); Wheel Tractors (with Dozer, Hoe or Endloader Attachments); CAT Earthwork Compactors and Similar Types; Blaw Knox Spreader and Similar Types; Trench Machines; Pump Crete - Belt Crete - Squeeze Crete - Screw Type Pumps and Gypsum (operator will clean); Creter Crane; Operation of Concrete Pump Truck; Formless Finishing Machines; Flaherty Spreader or Similar Types; Screed Man on Laydown Machine; Vermeer Concrete Saw; Operation of Laser Screed; Span Saw; Dredge

Leverman; Dredge Engineer; Lull or Similar Type; Hydro-Boom Truck; Operation of Guard Rail Machine; and Starting Engineer on Pipeline or Construction (11 or more pieces) including: Air Compressor (Trailer Mounted), All Forced Air Heaters (regardless of Size), Water Pumps (Greater than 4-1/2" or Total Discharge Over 4-1/2"), Light Plants, Generators (Trailer Mounted - Excluding Decontamination Trailer), Welding Machines (Any Size or Mode of Power), Conveyor, Mixer (any size), Stud Welder, Power Pac, etc, and Ground Heater Trailer Mounted).

CLASS 2. Bulker & Pump; Power Launches; Boring Machine & Pipe Jacking Machine; Dinkeys; Operation of Carts, Powered Haul Unit for a Boring Machine; P & H One Pass Soil Cement Machines and Similar Types; Wheel Tractors (Industry or Farm Type - Other); Back Fillers; Euclid Loader; Fork Lifts; Jeep w/Ditching Machine or Other Attachments; Tunneluger; Automatic Cement & Gravel Batching Plants; Mobile Drills – Soil Testing and Similar Types; Pugmill with Pump; All (1) and (2) Drum Hoists; Dewatering System; Straw Blower; Hydro-Seeder; Bump Grinders(self-propelled); Assistant Heavy Equipment Greaser; Apsco Spreader; Tractors (Track-Type) without Power Units Pulling Rollers; Rollers on Asphalt - Brick or Macadam; Concrete Breakers; Concrete Spreaders; Cement Strippers; Cement Finishing Machines & CMI Texture & Reel Curing Machines; Vibro-Tampers (All Similar Types Self-Propelled); Mechanical Bull Floats; Self-Propelled Concrete Saws; Truck Mounted Power Saws; Operation of Curb Cutters; Mixers - Over Three (3) Bags; Winch and Boom Trucks; Tractor Pulling Power Blade or Elevating Grader; Porter Rex Rail; Clary Screed; Mule Pulling Rollers; Pugmill without Pump; Barber Greene or Similar Loaders; Track Type Tractor w/Power Unit attached (minimum); Fireman; Spray Machine on Paving; Curb Machines; Paved Ditch Machine; Power Broom; Self-Propelled Sweepers; Self-Propelled Conveyors; Power Subgrader; Oil Distributor; Straight Tractor; Truck Crane Oiler; Truck Type Oilers; Directional Boring Machine; Horizontal Directional Drill; Articulating End Dump Vehicles; Starting Engineer on Pipeline or Construction (6 -10 pieces) including: Air Compressor (Trailer Mounted), All Forced Air Heaters (regardless of Size), Water Pumps (Greater than 4-1/2" or Total Discharge Over 4-1/2"), Light Plants, Generators (Trailer Mounted - Excluding Decontamination Trailer), Welding Machines (Any Size or Mode of Power), Conveyor, Mixer (any size), Stud Welder, Power Pac, etc., and Ground Heater (Trailer Mounted).

CLASS 3. Straight Framed Truck Mounted Vac Unit (separately powered); Trac Air Machine (without attachments); Rollers - Five Ton and Under on Earth and Gravel; Form Graders; Bulk Cement Plant; Oilers; and Starting Engineer on Pipeline or Construction (3 - 5 pieces) including: Air Compressor (Trailer Mounted), All Forced Air Heaters (regardless of Size), Water Pumps (Greater than 4-1/2" or Total Discharge Over 4-1/2"), Light Plants, Generators (Trailer Mounted - Excluding Decontamination Trailer), Welding Machines (Any Size or Mode of Power), Conveyor, Mixer (any size), Stud Welder, Power Pac, etc., and Ground Heater (Trailer Mounted).

Other Classifications of Work:

For definitions of classifications not otherwise set out, the Department generally has on file such definitions which are available. If a task to be performed is not subject to one of the classifications of pay set out, the Department will upon being contacted state which neighboring county has such a classification and provide such rate, such rate being deemed to exist by reference in this document. If no neighboring county rate applies to the task, the Department shall undertake a special determination, such special determination being then deemed to have existed under this

determination. If a project requires these, or any classification not listed, please contact IDOL at 217-782-1710 for wage rates or clarifications.

LANDSCAPING

Landscaping work falls under the existing classifications for laborer, operating engineer and truck driver. The work performed by landscape plantsman and landscape laborer is covered by the existing classification of laborer. The work performed by landscape operators (regardless of equipment used or its size) is covered by the classifications of operating engineer. The work performed by landscape truck drivers (regardless of size of truck driven) is covered by the classifications of truck driver.

PROTECTION OF THE PUBLIC

In general, protection of the public shall be in accordance with Chapter 26, Article V of the Code of the City of Peoria, Illinois entitled "Excavation Generally," except that Sections 26-139, 26-140, 26-141 and 26-142 shall not apply.

Barricades, warning signs, and other devices shall be maintained as provided for by the City Code herein referred. The cost of any signs, barricades, or warning devices required to adequately accomplish partial or complete closure of streets shall be incidental to the contract and no additional compensation will be allowed.

TRAFFIC CONTROL & PROTECTION

Unless written permission is given by the City for a full closure, only one side of the road may be closed at a time. Full closures needed should be identified and discussed at the preconstruction meeting. If permission is given for a full closure, the Contractor is responsible for notifying Emergency Services a minimum of 48 hours in advance of the work. The contractor is responsible for written notification to the property owners a minimum of one week in advance of the work **and** 48 hours in advance of the work and coordinating access for property owners.

Traffic control shall be in accordance with the applicable sections of the "Standard Specifications for Road and Bridge Construction," the applicable guidelines contained in the "Manual on Uniform Traffic Control Devices for Streets and Highways," these special provisions, and any special details and Highway standards contained herein and in the plans. This item is incidental to the contract and no additional compensation shall be allowed.

Special attention is called to Articles 107.09 and 107.14 of the "Standard Specifications for Road and Bridge Construction," applicable "Recurring Supplemental Specifications and Special Provisions" and the following Highway Standards relating to traffic control:

(701301-04; 701501-06; 701601-08; 701602-06; 701606-08; 701701-08; 701801-05; & 701901-02)

When construction operations require the closure of one lane, except turn lanes, the closure of said lane shall require the use of the specified arrow board per Standard 701901-02. The work shall be performed as directed by the Owner's Representative.

Traffic movement should be inhibited as little as practical. Motorists should be guided in a clear and positive manner while approaching and traversing construction work areas. To ensure acceptable

levels of operation, routine inspection of traffic control elements should be performed. The Contractor will be required to inspect and initiate any needed maintenance to the traffic control devices on this contract. All traffic control devices shall be removed immediately when no longer needed. Construction equipment, materials and debris should be stored in such a manner as to not be vulnerable to vehicle impact, as directed by the Owner's Representative.

The Contractor is expected to maintain a minimum of one lane open to traffic at all times for traffic. The roadway may be closed for short periods in order to offload materials. However, this operation must take place with proper traffic control signage and/or flagmen as noted in the traffic control standards contained herein. Roadway closures, regardless of duration must be coordinated with City of Peoria Police and Fire Departments. It is absolutely necessary that one lane of roadway can be used by fire, police, and other emergency vehicles at all times under all weather conditions.

The Contractor shall, at all times, maintain a means for sidewalk traffic to detour the job. The Contractor shall also provide a minimum of interference to vehicular traffic and shall maintain barricades and warning signs as provided by the "Standard Specifications for Road and Bridge Construction."

The Contractor will be responsible for scheduling their operations to provide access to all businesses located along the improvement that have current access to the street. No less than one entrance to each commercial parking lot or building shall remain open at all times during construction.

The Contractor will be responsible with scheduling garbage pickup in the neighborhoods.

Non-Conformance: If the Contractor fails to comply with the above conditions, the Owner's Representative may suspend the Contractor's work until the Contractor is in compliance with the above conditions.

ITEMS DESIGNATED FOR REMOVAL AND EXCAVATION

All removal items and excavated material remain the property of the City of Peoria unless the City indicates a desire to the Contractor that they should dispose of the removed items and/or excavated material outside the limits of the improvement as the Contractor may provide. Should the City desire to keep the removed items and/or excavated material and have it disposed of at a location outside the improvement limits, the Contractor shall haul to the City's designated disposal site, at no additional cost to the City, providing the disposal site is within the limits of the City of Peoria.

SALVAGING EXISTING MATERIALS

All existing municipally owned items (street castings, millings, pavement brick, etc.) in usable condition within the limits of the improvement shall, if not required for further use in the construction of the improvement, be carefully preserved by the Contractor. Sidewalk brick shall not be considered pavement brick and the contractor will have the salvage rights to the sidewalk brick removed. Contractor shall delivered salvaged items to the Darst Street facility or as directed by the City. Coordinate with the City for the exact location

The cost of salvaging and hauling existing salvaged items shall incidental to the contract.

CITY SIGNS

The contractor, at their own expense, shall be required, as directed by the Engineer, to relocate or remove and reinstall all street, traffic, parking, etc. signs belonging to the City within the limits of the improvement. All signs which interfere with construction operations shall be removed, stored in a place away from work, and replaced by the contractor after the improvement has been completed if they are not required for traffic control. Signs which are required for traffic control shall be reinstalled at a temporary location acceptable to the Engineer, in a workmanlike manner, visible to traffic, and maintained straight and neat for the duration of the temporary setting. Signs shall not be moved until progress of the work demands the relocation. The cost of this item shall be included in the contract unit price bid for the item of work which necessitated the removal.

CONSTRUCTION DEBRIS

In accordance with Public Act 90-761 the following shall be added to the third paragraph of Article 202.03 of the "Standard Specifications for Road and Bridge Construction:"

The Contractor shall not conduct any generation, transportation, or recycling of construction or demolition debris, clean or general or uncontaminated soil generated during construction, remodeling, repair, and demolition of utilities, structures, and roads that is not commingled with any waste, without the maintenance of documentation identifying the hauler, generator, place of origin of the debris or soil, the weight or volume of the debris or soil, and the location, owner, and operator of the facility where the debris or soil was transferred, disposed, recycled or treated. This documentation must be maintained by the Contractor for 3 years.

A sample of a Construction Debris Manifest has been placed at the back of this contract book, for use in documenting any debris removed from the site. This documentation shall be included in applicable item of construction and shall not be paid for separately.

DAMAGE TO EXISTING TREES

All necessary precautions shall be taken to prevent damage to existing trees. Roots of two inch (2") diameter or more shall not be severed. Precautions shall be taken to prevent damage to the bark, branches and foliage of existing trees by machinery or other means. Any damage shall be corrected as directed by the City at the expense of the Contractor.

GUARANTEE PERIOD

The Contractor warrants all work performed under this contract is free from defects and was performed in accordance with the Contract Documents for a period of one (1) year from the date of agreement of final quantities, as agreed in writing, by the City Engineer after all parties have signed the document. In case of acceptance of a part of the work for use prior to the agreement to final quantities, the guarantee for the part so accepted shall be for a period of one (1) year from the date of such partial acceptance, in writing, by the City Engineer. Work performed due to this warranty requirement shall be guaranteed for a period of one (1) year. The Guarantee Period may be further amended in the Special Provisions.

PART 3-SPECIAL PROVISIONS

STATE OF ILLINOIS
CITY OF PEORIA
Special Provisions

The following Special Provisions supplement the "Standard Specifications for Road and Bridge Construction," adopted April 1, 2016, the latest edition of the "Illinois Manual on Uniform Traffic Control Devices for Streets and Highways" in effect on the date of invitation for bids, the "Standard Specifications for Traffic Control Items," adopted April 1, 2016 and the "Supplemental Specifications and Recurring Special Provisions", adopted April 1, 2016, included herein which apply to and govern the construction of the **NORTH WISCONSIN AVENUE ORNAMENTAL LIGHTING (McCLURE AVENUE TO EAST REPUBLIC STREET)** project, in the City of Peoria, Peoria County, and in case of conflict with any part of said specifications, the said Special Provisions shall take precedence and shall govern.

MEASUREMENT METHODS

Pay items shall be measured in accordance with the City of Peoria Manual of Practice and the IDOT standard specifications and as modified in these specifications.

EROSION CONTROL

The Contractor shall install erosion control systems as necessary or as directed by the Engineer to prevent sediment from entering the City's storm drainage system or exiting the construction area. Erosion control systems shall be installed as necessary or as directed by the Engineer prior to stockpiling of material on the project site. The Contractor shall be responsible for the cost of cleanup and damages resulting from failure to comply with this provision. This work shall be considered incidental to the affected items of work and no additional compensation will be allowed.

The Contractor shall sweep and return to the work site any soil tracked onto the street by the end of the workday or before four (4) hours has elapsed, whichever is sooner. This work shall be considered incidental to the affected items of work and no additional compensation will be allowed.

This work will not be paid for separately but shall be considered incidental to the contract.

UNDERGROUND CONDITIONS

Unless provided within these Specifications, information about underground conditions within and near the area of work has not been obtained by the Engineer or City. The Contractor shall either determine the underground conditions near the proposed construction or repair locations and determine the effect of such conditions upon the proposed work. The Contractor shall assume all risks and accept all costs attributable to unknown and unforeseen underground conditions. Underground conditions such as the presence of underground obstructions or poor soil conditions shall not be a basis for claims for additional compensation.

PORTLAND CEMENT CONCRETE SIDEWALK

This item includes all costs associated with providing and installing concrete sidewalk at locations directed by the City of Peoria in accordance with the specifications herein.

The Contractor must construct Portland cement concrete sidewalks as directed by the Engineer. The sidewalk must be constructed to the lines, grades and dimensions established in the field.

This work includes removal of existing sidewalk at locations identified by the City of Peoria.

The work includes removing and disposing of surplus material not removed under other items of the Contract; preparation of the subgrade; formwork; furnishing and placing concrete, preformed joint filler and asphalt for sealing joints; and all necessary incidental work to complete the sidewalks as specified, all of which various classes of work must be performed as herein specified.

Excavate, prepare and compact subgrade to 95% of maximum laboratory density and in accordance with Section 424 of the Standard Specifications. The Contractor shall provide a 4-inch sub-base under all new sidewalk locations.

Materials and workmanship must conform to the following requirements:

Sidewalks must conform to the requirements of Section 424, "Portland Cement Concrete Sidewalk," of the Standard Specifications and the Illinois Accessibility Code.

No extra or customary measurement of any kind will be allowed. The sidewalk will be measured in place as the square feet of sidewalk within the limits shown on the Plans or directed by the Engineer. No deductions will be made from the measured area of sidewalk for light standards, sidewalk lights, manholes or other similar structures.

This item shall be paid for at the contract unit price per SQUARE FOOT for PORTLAND CEMENT CONCRETE SIDEWALK, and shall be payment in full for all material, labor, tools and equipment required to complete this item of work as specified.

REMOVAL AND DISPOSAL OF UNSUITABLE MATERIAL

This work shall be performed in accordance with section 202 of the "Standard Specifications for Road and Bridge Construction."

This work shall consist of the removal and disposal of unsuitable sub-grade material that is excavated at foundation locations, hand hole locations, and bore lengths. This work shall be performed at the discretion of the Engineer.

This work will be paid for at the contract unit price for CUBIC YARD of REMOVAL AND DISPOSAL OF UNSUITABLE MATERIAL which shall include all labor, material, and equipment necessary to complete this work.

STREET LIGHTS

Responsibility Of The Bidder

The installation shall comply with codes which are applicable. The electrical devices to be installed shall be compatible with the electrical requirements of the system and shall equal or exceed the capacity required. If the bidder finds instances in which governing codes will be violated or the items which are specified not compatible or have inadequate capacity, the bidder shall immediately advise

the Engineer to enable the Engineer to take proper action before awarding the contract. Where it is necessary to make such changes after the contract is awarded, no extra payment will be allowed.

Before submitting a bid, the bidder shall confer with the company supplying service to these installations and determine its charges for extending or modifying its lines and/or making any other provisions for serving the installation. These charges are included with certain pay items as indicated herein and no additional compensation will be allowed.

Responsibility Of The Contractor

The Contractor shall deliver complete lighting systems, thoroughly tested and in operating condition. In addition, the Contractor shall complete the proposed improvement within the working days allowed for this project. The Contractor is cautioned to use the procedures outlined. For example, it is necessary that the wiring be meggered in the presence of the Engineer. All defective or damaged parts must be replaced at no extra cost before payment will be made, even though approval has been given to use the parts on the basis of manufacturer's specification and descriptions.

Any negligence on the part of the Contractor to comply with these Provisions or any part thereof, may be considered by the City of Peoria as cause for default of contract in accordance with Article 108.10 of the Standard Specifications for Road and Bridge Construction.

The drawings indicate the locations of service installation, control center, lights, handholes, conduits and wiring. Any minor change in the locations of these items from those shown on the plans will be made without additional charge, if so directed by the Engineer.

The Contractor, at his/her own expense, shall furnish all materials, equipment and labor necessary in performing the final inspection.

All inconveniences, delays or additional expense caused by the Contractor in complying with these Special Provisions, shall be considered included in the contract and no additional compensation will be allowed.

Delivery of Materials

The Contractor shall coordinate with the City of Peoria to determine his/her progress schedule based on the manufacturer's projected delivery date on all materials whether furnished by the Contractor or the City of Peoria.

Approval of Materials

Electrical materials shall be new and of the types and kinds approved by the Underwriter's Laboratories, Inc.

Before any work is started, the Contractor shall obtain written approval from the Engineer to install the materials he/she proposed to furnish. Within thirty (30) days after the award of the contract, he/she shall submit the following to the Engineer for approval: a letter affirming that copies of the

Special Provisions applying to luminaires have been sent to the respective manufactures; a sample of all cables, conductors and unit duct and a typical splice; and three (3) copies of photometric data including isofootcandle diagram, utilization curve and isocandela diagram for each pattern of each type of luminaire specified, description of tilt indicator, pattern indicator, ballast, conductor, circuit breakers, selector switch, cabinet, pedestal and insulating panel board, time switch, photocell and fused safety switch.

Guarantees

If a guarantee is included in the standard sale price of any items at no extra cost, the Contractor shall supply the Engineer with a copy. Lamps, luminaires, ballasts, photocells, contactors and circuit breakers may have such a guarantee.

Acceptance

Final acceptance shall be concluded after test data is approved and a final inspection of the system by the Engineer warrants that the system is complete and according to specifications.

Work By Other

The completion of this project may involve, in addition to the Contractor's work, utility adjustments or relocation by various utility companies.

Wire And Cable

The following modifications apply only to wire and cable for roadway lighting.

1. Revise the second sentence of the first paragraph of Article 1066.02(a) to read:
"The cable shall be rated at a minimum of 90°C dry and 75°C wet and shall be suitable for installation in wet and dry locations, and shall be resistant to oils and chemicals."
2. Revise the third paragraph of Article 1066.02(a) to read:
"All conductors shall be stranded. Stranding meeting ASTM B 8, ICEA S-95-658/NEMA WC70 and UL Standard 44. Uncoated conductors meeting ASTM B 3, ICEA S-95-658/NEMA WC70 and UL Standard 44."
3. Add the following to Article 1066.03 of the Standard Specifications:
"The cable shall be rated 600 volts and shall be UL Listed Type RHH/RHW/USE."
4. Revise Article 1066.08 to read:
"Electrical Tape. Electrical tape shall be all weather vinyl plastic tape resistant to abrasion, puncture, flame, oil, acids, alkalies, and weathering, conforming to Federal Specification MIL-I-24391, ASTM D1000 and shall be listed under UL 510 Standard. Thickness shall not be less than 0.215 mm (8.5 mils) and width shall not be less than 20 mm (3/4-inch)."

LIGHT POLE, DECORATIVE

This work shall consist of furnishing, transporting, and installing a decorative light pole, which includes the pole, fixture, in-line fuses, surrestor and all electrical cable in the pole in accordance with Section 821 and 830 of the Standard Specifications, the plans and as directed by the Engineer.

The pole assembly shall be cast aluminum and supplied in one piece unitized construction and be manufactured by Holophane (Unit Part # ZW10C17CABKH) 10' Wadsworth Pole or approved equivalent. The pole assembly height, not including tenon, shall be 10'.

The cast aluminum raised fluted base with the overall height of 19" and base diameter of 17" with a minimum wall thickness of 0.200 inches. The decorative base shall have uniform fluted sections and contain a concealed wire access door with 7" x 1 1/4" slotted holes evenly spaced on 12 inches diameter bolt circle.

Pole shaft shall be approximately four inches (4") diameter at the top and taper to approximately six and one-half inches (6 1/2") at the bottom. The pole shaft shall be a one piece casting with a minimum wall thickness of 0.200 inches. The shaft shall have uniform and sharply defined flutes extending the length of the shaft. Pole shall have a 3" diameter tenon 3" in length. Tenon length shall not be included in length of pole.

Pole assembly shall be free from visible pits, flashing, pattern seams, sand marks and shall have no sharp edges. Weld beads shall not be visible on exposed surfaces, or they shall be finished smooth. Pole assembly shall be wire brushed and thoroughly cleaned with acid and rinsed. All exposed surfaces shall be coated with a weather resistant polyester thermoset powder (triglycidyl isocyanurate TGIC), high gloss black finish. Powder shall be electrostatically applied, oven cured and bonded to a minimum dry film thickness of 2.0 mils. Coating shall be warranted against cracking, peeling, excessive color change and fading due to normal climatic exposure for a period of five (5) years from the date of shipment.

Pole shall be designed to withstand 90 mph wind load with City Standard fixtures attached. Manufacturer shall supply one-year warranty covering defects in manufacture and finish.

The fixture assembly shall consist of cast aluminum globe holder, electrical module, luminaire housing, necessary hardware and wiring, and vandal resistant globe and manufactured by Holophane (Part# GVE 058 AS B 2 N N U LED Acorn Fixture) or approved equal.

The acorn shaped globe shall be glass. The globe shall be of one-piece construction and shatterproof.

The cast aluminum globe holder shall be mounted on 3" diameter by 3" long tenon as cast, or with supplied aluminum adaptor. Globe holder shall be secured to pole with four stainless steel set screws. Globe shall be secured by four stainless steel set screws. Globe holders shall be finished smooth, free from visible pits, flashing, pattern seams, and sand marks, and shall have no sharp edges. Globe holder shall be chemically cleaned and rinsed. All exposed surfaces shall be coated with polybutyl resin primer a minimum of 2 mils thick. All exposed surfaces shall be coated with two 4 mil layers of high gloss black aliphatic polyurethane plastic. The finish shall be guaranteed for 12 months against cracking, blistering, peeling, softening, noticeable fading, or chalking.

The acorn optical system shall contain a thermo resistant borosilicate glass refractor and top reflector.

Refractors shall be designed for I.E.S. type III distribution.

Luminaire housing, as required for 60-watt (LED) system, shall be enclosed with cast aluminum enclosure and held in place with stainless steel fasteners. Luminaire housing shall be removable.

<u>Type</u>	<u>Watts</u>	<u>No LED</u>	<u>LPW</u>	<u>Rated Life</u>
LED	60	5	80	100,000

Basis of Payment

Work will be paid for at the contract unit price EACH for LIGHT POLE, DECORATIVE which price shall be considered payment in full for all labor, equipment, and material necessary to complete the fixture, assembly, fittings, LED light, and pole work as specified

LIGHT POLE FOUNDATION

This work shall consist of constructing a concrete foundation for the light poles in accordance with applicable portions of Section 836 of the Standard Specifications, the details in the plans, and the following additions or exceptions.

The No. 6 AWG bare, solid copper grounding electrode conductor shall be exothermically welded to the ground rod. The exothermic weld shall be included in the cost of the concrete foundation.

The top of the foundation shall be set at the same elevation as the highest contact with grade, as shown on the plans or as directed by the Engineer. The top edge shall be beveled.

The form shall hold the anchor bolts in a vertical position; so that neither less than 3/8" nor more than 1" will protrude through the top of the self locking nut when the standard is mounted, and in the proper position to accept the standard. This may vary from standards to standard and it is the Contractors responsibility to place the bolts to each standard.

The exposed portion of the foundation shall be finished smooth. The top shall be level. Shims and grouting will not be permitted to plumb the lighting equipment.

The foundation shall be allowed to set or cure for seven (7) days before the pole is set, during which the anchor bolt ends and exposed concrete shall be protected from mechanical and weather damage.

LIGHT POLE FOUNDATION will be measured for payment in units of each which will include the concrete foundation, conduit bends, fittings and excavation.

This work shall be paid for at the contract unit price per EACH for LIGHT POLE FOUNDATION, which price shall be payment in full for all labor and materials necessary to complete the work described above.

CONCRETE HANDHOLE

This work shall consist of furnishing and installing a handhole in accordance with Articles 814.03 to 814.05 of the Standard Specifications and the construction plans.

Work will be paid for at the contract unit price per EACH for CONCRETE HANDHOLE of the type specified, which prices shall be considered payment in full for all labor, equipment, and material necessary to complete the work as specified

ELECTRICAL CONDUCTORS – SLACK REQUIREMENTS

Sufficient length of electrical conductors shall be installed in handholes and in light standards to provide adequate slack so that electrical conductors may be pulled a minimum of 18" out of pole handhole. Said slack shall be neatly coiled and placed in the handholes.

This item shall not be paid for separately but shall be included in the contract unit price for the structure in which placed.

GROUNDING

All poles and handholes shall be connected to a continuous ground consisting of a green insulated electrical conductor 600 V, XLP, 1/C, No. 6. This conductor shall be placed inside the conduit along with the insulated cables.

The ground conductor shall have no splice or kinks below grade. It shall be solidly connected to the grounding lug of each pole and to the ground rod at the service installation.

All driven grounds, connectors, connecting ground wire and their installation are included in the cost of the device being grounded. No extra compensation will be allowed. The continuous ground will be measured in feet in-place and shall be paid at contract unit price per foot for ELCBL in conduit, 600 V, XLP, 1/C, No. 6, green, which shall be payment in full for all equipment, tools, labor and materials necessary to complete this work.

CONDUIT

This work consists of furnishing and installing the necessary conduit system for the decorative street lighting system. **It is the intent of this contract that the conduit shall be pushed with minimal disruption to existing sidewalks, driveways, roadways, retaining walls, etc.** The work includes conduit pushed under existing roadways and driveways and all necessary bends, sweeps, pole attachments, risers and attachment hardware. Aluminum attachment hardware will not be permitted where same come in contact with concrete surfaces.

Transition from PVC conduit to galvanized conduit shall be at least 10 feet back from where the conduit exits the ground surface.

Work will be paid for at the contract unit price per LINEAR FOOT for CONDUIT (2") and wire of the type specified, which prices shall be considered payment in full for all labor, equipment, and material necessary to complete the work as specified.

WIRING TESTS

The tests outlined in this section are witness tests to be performed during construction in the presence of the Engineer at times approved by the Engineer. They shall be performed by the Contractor's personnel and with his equipment. The cost is incidental and no extra compensation will be allowed.

Testing will be performed at opportune times before final inspection. Defects shall be corrected and testing repeated until all sections of the installation are sound. Splicing or repairing of insulation below grade is not permissible except in handholes.

All data required herein shall be read and recorded at the time of the test by the Engineer in the log which will be retained by him for examination and approval at the time of final inspection. It is the responsibility of the Contractor to make certain that the log is complete and the data proves that the system performance exceeds the minimum requirements. Approval for payment will be given only if a complete log is submitted by the Engineer at time of final inspection and the final, corrected system meets the minimum requirements.

It is the purpose of the test to confirm the quality of insulation in the ballasts and wiring. All construction shall be finished when tests are made. The poles shall be erected with ballasts and lamps in-place. Trenches shall be backfilled and all connections shall be made up in handholes, poles and control cabinets.

Insulation resistance shall be measured with a megger generating not less than 500, nor more than 1,000 volts. A multimeter is not acceptable because it applies only a few volts which will permit some insulation defects to go undetected. Erratic behavior of the megger during the test indicates an intermittent weakness which must be corrected. Only the lowest value indicated shall be considered or recorded.

The Engineer shall log the serial number and voltage rating of the megger used by the Contractor. He shall then confirm the calibration of the megger by connecting the two leads of the megger together so that the resistance to be measured by the megger when it is turned to full speed is zero. Unless this is true, the megger will give false readings under all other circumstances as well.

Each circuit shall be permanently tagged for identification and then tested at the control centers. The full voltage of the megger shall be applied between ground and each insulated wire in each circuit. The ground shall consist of a driven, copper clad rod 8' x 5/8" or larger, connected by #6 wire to the power company neutral in the control cabinet. Circuits shall be isolated from each other by opening the circuit breakers.

The minimum acceptable resistance to ground shown by the megger shall be as follows:

<u>Wire Tested</u>	<u>Minimum Megger Resistance to Ground</u>
To power source	40 megohms minimum
To photocell	40 megohms minimum
1 to 2 lights connected to wire being tested	40 megohms minimum

3 to 4 lights connected to wire being tested	20 megohms minimum
5 to 8 lights connected to wire being tested	10 megohms minimum
9 or more lights connected to wire being tested	5 megohms minimum

The megger shall be operating at full crank speed when it is read. If needle fluctuates, the lowest resistance value shall be recorded.

If any conductor has less resistance than that shown above, it shall be rejected regardless of atmosphere, groundwater or other conditions which may be alleged to be the reason. Defective cables shall be replaced and retested until satisfactory.

VOLTAGE REGULATION AND CURRENT BALANCE TESTS

It is the purpose of these tests to confirm the design values of voltage drop and the accuracy of the installed wiring layout. The test shall be performed in the sequence given as rapidly as possible, except for the five minute warm-up. Only one voltmeter and one ammeter shall be used to eliminate discrepancies between instruments. The instruments shall not be adjusted after testing begins.

1. Turn lights on and record "starting" current in supply phase wires A and B.
2. After lights are on five minutes:
 - a) Record "operating" current in phase wires A and B;
 - b) Record phase voltage;
 - c) Record voltage across ballast in handhole in end light of circuit designated by Engineer;
 - d) Record voltage of same circuit at control center to determine voltage drop between end lamp and control center; and
 - e) Record current in each lighting circuit.

WIRING TEST LOG SHEET

(One REQUIRED for each control of service center)

Control Center Number: _____

MEGGER DATA:

Volts generated _____ volts

(Must be 500 to 1,000)

Scale used: 0 to _____ megohms

Manufactured by:

Serial Number:

CONSTRUCTION STATUS:

Wiring complete _____ Incomplete _____

Trenches open _____ Backfilled _____

MEGOHMS TO GROUND:

Wire A to power supply _____ megohms

Wire B to power supply _____ megohms

Wire A to lighting circuit 1 _____ megohms

Wire B to lighting circuit 1 _____ megohms

Wire A to lighting circuit 2 _____ megohms

Wire B to lighting circuit 2 _____ megohms

Wire A to lighting circuit 3 _____ megohms

Wire B to lighting circuit 3 _____ megohms

AMPERES:

Wire A to power supply, initial _____ amperes

Wire B to power supply, initial _____ amperes

Wire A to power supply, after 5 minutes on _____ amperes

Wire B to power supply, after 5 minutes on _____ amperes

Wire A, Circuit 1 - after 5 minutes on _____ amperes

Wire A, Circuit 2 - after 5 minutes on _____ amperes

Wire A, Circuit 3 - after 5 minutes on _____ amperes

Wire A, Circuit 4 - after 5 minutes on _____ amperes

REGULATION: (Make following tests in order shown with lights burning after they have been on for five (5) minutes or more).

- 1) Voltage in control cabinet between Wire A and Wire B to Power supply _____ volts
- 2) Voltage between Wire A and Wire B at most distant light (designated by Engineer) _____ volts
- 3) Voltage in control cabinet between Wire A and Wire B to Power supply (same as 1) _____ volts

Engineer

Service Installation

**PART 4-EQUAL OPPORTUNITY
REQUIREMENTS**



EEO CONTRACT COMPLIANCE CLAUSE

It is hereby declared to be the public policy of the City of Peoria, that it will not execute a contract for goods and/or services with any individual, business enterprise, supplier/vendor; maintain a financial relationship with any financial institution; or use the services of any labor organization or member thereof found to be in violation of the provisions of the Municipal Code for the City of Peoria, Chapter 17, Article III, Division 4, Section 17-118.

This clause covers contractors, vendors, suppliers, borrowers and/or recipients of city resources, purchasers and/or developers of city owned property, and any other individuals or entities providing goods and/or services to the City of Peoria; and are hereinafter referred to as "Contractor".

If any Contractor conducting business with the City of Peoria fails to comply with the fair employment and affirmative action provisions of Chapter 17, Article III, Division 4 of the municipal code (hereinafter Chapter 17), the city, at its option, may do any or all of the following:

- (1) Cancel, terminate, or suspend the contract in whole or in part;
- (2) Declare the contractor ineligible for further contracts for one calendar year;
- (3) The Fair Employment and Housing Commission (hereinafter FEHC), in accordance with its rules and regulations, shall have the power to impose a penalty upon any Contractor failing to comply with Chapter 17 in an amount not less than \$50.00; nor more than as provided in Chapter 1, Section 1-5 of the municipal code, for each day that the Contractor fails to comply, upon a specific finding of such violation. The FEHC may order a Contractor found guilty of failure to comply with the provisions of Chapter 17 to pay all or a portion of the legal costs incurred by the city as a result of prosecution of such violations. Penalties assessed under the this clause may be recovered from the Contractor by setoff against unpaid portion of the contract price; and
- (4) Such other sanctions as may be imposed by the FEHC pursuant to the provisions of Chapter 17 and other applicable ordinance provisions of the municipal code.

During the performance of this contract, the Contractor agrees:

- (A) That it will not discriminate against any employee or applicant for employment because of race, color, religion, sex, sexual harassment, ancestry, national origin, place of birth, age, or a physical and/or mental disability which would not interfere with the efficient performance of the job in question. The contractor/vendor will take affirmative action to comply with the provisions of Peoria City Code, Chapter 17 and will require any subcontractor to submit to the City of Peoria a written commitment to comply with this division. The Contractor will distribute copies of this commitment to all persons who participate in recruitment, screening, referral, and selection of job applicants, prospective job applicants, members, or prospective contractors.

The Contractor agrees that the provisions of Chapter 17, of the Municipal Code of the City of Peoria is hereby incorporated by reference, as if set out verbatim

- (B) That it will examine each one of its workforce job classifications to determine if minorities and/or females are underutilized; and it will take appropriate affirmative action steps to rectify such identified underutilization.
- (C) That if it hires additional employees in order to perform this contract or any portion thereof, it will determine the availability of minority and females in the area(s) from which it may reasonably recruit; and every good faith effort will be made in its selection process to minimize or eliminate identified areas of minority and/or female underutilization for each job classification for which there are employment opportunities.
- (D) That during the performance of this contract, the Contractor will maintain its eligibility status to conduct business with the City of Peoria under the provisions of the EEO certification registration program.
- (E) That in all solicitations or advertisements for employees placed by it or on its behalf, it will state that all applicants will be afforded equal opportunity without discrimination because of race, color, sex, religion, national origin, age, or physical and/or mental disability.
- (F) That it will send to each labor organization or Representative of workers with which it has or is bound by a collective bargaining agreement or understanding, a notice advising such labor organization or Representative of the Contractor's obligations under Chapter 17. If any such labor organization or Representative fails or refuses to cooperate with the Contractor in its efforts to comply with Chapter 17, the Contractor will promptly so notify the Equal Opportunity Office (hereinafter EOO) and/or the FEHC for the City of Peoria.
- (G) That it will submit reports as required and furnish all relevant information as may from time to time be requested the EOO and/or the FEHC.
- (H) That it will permit access to all relevant books, records, accounts and work sites by EOO staff members for purposes of investigation to ascertain compliance with Chapter 17.
- (I) That it will include verbatim or by reference the provisions of Section 17-120 of Chapter 17 so that such provisions will be binding in the same manner as with other provisions of this contract. The Contractor will be liable for compliance with applicable provisions of this clause by all its subcontractors; and further, it will promptly notify the EOO and/or FEHC in the event any subcontractor fails or refuses to comply therewith. In addition, no Contractor will utilize any subcontractor declared by the EOO and/or FEHC to be non-responsive and therefore, ineligible for contracts

or subcontracts with the City of Peoria.

- (J) That during the performance of this contract, the Contractor agrees: that it will have written sexual harassment policies that shall include, at a minimum, the following information: (i) the illegality of sexual harassment; (ii) the definition of sexual harassment under state law; (iii) a description of sexual harassment utilizing examples; (iv) the contractor's internal complaint process including penalties; (v) the legal recourse, investigative and complaint process available through the Illinois Department of Human Rights and the Human Rights Commission; (vi) directions on how to contact the Department of Human Rights and the Commission; and (vii) protection against retaliation as provided by Section 6-101 of this Act (Public Act 87-1257). A copy of the policies shall be provided to the Illinois Department of Human Rights or the City of Peoria upon request.
- (K) That during the performance of this contract, the Contractor agrees that they do not and will not maintain or provide for their employees, any segregated facilities at any of their establishments, or permit employees to perform their services at any location under their control where segregated facilities are maintained.

As used in this document, the term segregated facilities means any waiting rooms, work areas, rest rooms and wash rooms, and other storage or dressing areas, parking lots, drinking fountains, recreation or entertainment areas, transportation, housing facilities provided for employees which are segregated by explicit directive or are in fact segregated on the basis of race, religion, color, national origin, because of habit, local custom, or otherwise.

**MINORITY AND WOMEN'S BUSINESS ENTERPRISE (M/WBE) PARTICIPATION
REQUIREMENTS FOR GOOD-FAITH EFFORTS**
(Projects exceeding \$50,000)

I. Description of Program

- A. It is the policy of the City of Peoria to encourage participation of M/WBE's on all city-funded construction projects. In complying with this clause bidders are required, when subcontracting opportunities are available, to make a good-faith effort to meet the goals established for M/WBE participation. The participation goals are cited in Section VI on the Subcontractor Utilization Statement.
- B. Failure to submit the documentation requested in Sections II and III may cause (1) the bid to be rejected and determined non-responsive; (2) subject the bidders to the sanctions described in Section VIII.

II. Pre-Bid Efforts when Awarding Subcontracts

- A. Bidders are required to contact and solicit, in writing, bids from M/WBEs for available subcontracting. In seeking solicitations, bidders are to identify the portion(s) of work to be subcontracted and offer to break down any portion(s) of work into economically feasible units in order to facilitate M/WBE participation. Bidders also are to provide the name of a specific contact person in their notice to the M/WBEs. Contact shall be made prior to bid opening. A list containing the name of each company contacted, the date and method must be submitted with bid documents.

The low bidder shall provide to the City of Peoria, upon request, copies of faxes, letters, and e-mails sent to M/WBEs.

- B. Bidders who are a MBE or WBE are not exempt from soliciting bids for available subcontracting. The bidder is required to contact, in writing, firms that will help the bidder meet the participation goal for the targeted group opposite to which the bidder belongs. If the bidder is identified as both a MBE and WBE, the participation goals shall be deemed to have been met. In seeking solicitations, bidders are to identify the portion(s) of work to be subcontracted and offer to break down any portion(s) of work into economically feasible units in order to facilitate M/WBE participation. Bidders also are to provide the name of a specific contact person in their notice to the M/WBEs. Contact shall be made prior to bid opening. A list containing the name of each company contacted, the date and method must be submitted with bid documents.

The low bidder shall provide to the City of Peoria, upon request, copies of faxes, letters, and e-mails sent to M/WBEs.

III. Good-Faith Efforts Documentation when Utilizing Subcontractors

- A. All Bidders must provide proof of its compliance with the pre-bid requirements and good-faith efforts to the City. Both the pre-bid documentation and the support documentation requested below must be submitted with bid documents.
 - a. All Bidders must submit a properly completed “**Subcontractor Utilization Statement.**” All Bidders must provide the scope of work to be performed, the dollar amount to be paid, and the percentage amount of the contract for each company listed.
 - b. All Bidders must submit a list of qualified M/WBE’s who submitted proposals but will not be utilized. This list must include a justification for not accepting the proposed bid.
- B. Disputes arising from the enforcement of these requirements will be resolved by the Equal Opportunity Office.

IV. Waiver Requirements When Self-Performing All Work

- A. **All bidders will make every effort to make subcontract opportunities available to M/WBEs.** However, if such an opportunity cannot be made available, the Bidder must seek a waiver by submitting “**M/WBE Participation Waiver Request.**” The waiver request must be submitted to the City of Peoria with bid documents.
- B. For the M/WBE waiver request to receive consideration, the following supportive documentation that applies must accompany the form:
 - a. A narrative describing the Bidder’s good faith efforts to secure M/WBE participation prior to bid opening.
 - b. A notarized affidavit attesting the Bidder did not receive inquiries or proposals from qualified M/WBEs in response to the required notification prior to bid opening.
 - c. A written explanation for why the Bidder believes no subcontracting opportunities exist. *If the City of Peoria determines that the explanation is insufficient it reserves the right to halt the bid award process to request additional information from the Bidder. The Bidder will receive the request for information in writing.*
 - d. A written explanation for why the Bidder believes it is impracticable to award any subcontract(s) on the project in question. *If the Equal Opportunity Office determines that the explanation is insufficient it reserves the right to halt the bid award process to request additional information from the Bidder. The Bidder will receive the request for information in writing.*

V. Change In Use of Subcontractors or Self-Performance Status

- A. Before the General Contractor can deviate from utilizing any of the subcontractors listed on the Subcontractor Utilization Statement or its declared intent to self-perform, it must submit a completed **Notification of Change in Participation** form to the City of Peoria. Upon notification construction on the project may be delayed or halted until a review is conducted by the Equal Opportunity Office.
- B. Regarding a self-performance change, if a subcontracting opportunity has been made available, the General Contractor must identify all good faith efforts made to meet the M/WBE participation goals, unless the change was due to an emergency.

VI. Procedures for Counting M/WBE Participation toward Goals (*based upon Department of Transportation regulations*)

- A. When an M/WBE participates in a contract, count only the value of the work actually performed by the M/WBE toward M/WBE participation goals.
 - a. Count the entire amount of that portion of a construction contract (or other contract not covered by paragraph (A)(b) of this section) that is performed by the M/WBE's own forces. Include the cost of supplies and materials obtained by the M/WBE for the work of the contract including supplies purchased or equipment leased by the M/WBE (except supplies and equipment the M/WBE subcontractor purchases or leases from the prime contractor or its affiliate).
 - b. Count the entire amount of fees or commissions performed by an M/WBE firm towards M/WBE goals if that firm provides the Apparent Low Bidder a bona fide professional, technical, consultant, or managerial service or provides bonds or insurance specifically required in a City of Peoria contract.
 - c. If an M/WBE subcontracts a portion of its work to an M/WBE, 100% of the value of the subcontracted work may be counted toward the M/WBE goal, but any portion of the work the M/WBE subcontracts to a non-M/WBE does not count toward the M/WBE goal.
- B. When an M/WBE participates in a joint venture on a City contract, only count the dollar value of the portion of the work that the M/WBE performs with its own forces toward M/WBE goals.
- C. Count expenditures to an M/WBE contractor toward M/WBE goals if, and only if, the M/WBE is performing a commercially useful function on that contract.
 - a. An M/WBE performs a commercially useful function when it is responsible for performing, managing, and supervising its contracted work; moreover, with respect to materials and supplies used on the contract, it must also be responsible for negotiating its price, and purchasing and managing those supplies.
 - b. An M/WBE does not perform a commercially useful function if its role is limited to that of an extra participant in a transaction, contract, or project through which funds

are passed in order to obtain the appearance of M/WBE participation. It should be noted that an effort contrived to give the appearance of M/WBE participation is not considered a good faith effort and is considered an ethical violation that is subject to sanctions outlined in section V.

- c. If an M/WBE does not perform or exercise responsibility for at least 30% of the total cost of its contract with its own work force, you must presume that it is not performing a commercially useful function and the dollar amount of that work will not count toward the M/WBE goals.
 - d. When an M/WBE is presumed the City of Peoria not to be performing a commercially useful function as provided in paragraph (C)(c) of this section, the M/WBE may present evidence to rebut this presumption. Your rebuttal is subject to review by the City of Peoria.
- D. Use the following factors in determining if an M/WBE trucking company is performing a commercially useful function:
- a. The M/WBE trucking company must manage and supervise the trucking work it is being paid to perform. A contrived arrangement for the purpose of giving the appearance of meeting M/WBE goals is not considered a good faith effort.
 - b. The M/WBE trucking company must own and operate at least one fully licensed, insured, and operational truck used on the contract.
 - c. The M/WBE trucking company receives credit for the total dollar value of the transportation services it provides on the contract using trucks it owns, insures, and operates.
 - d. The M/WBE trucking company may lease trucks from another M/WBE trucking firm, including an owner-operator who is certified as an M/WBE. The M/WBE who leases trucks from another M/WBE receives total credit for the dollar value of the transportation services the M/WBE trucking lessee provides on the contract.
 - e. The M/WBE trucking company may also lease trucks from a non-M/WBE trucking firm, including an owner-operator. The M/WBE who leases trucks from a non-M/WBE is only entitled to credit for the fee or commission it receives as a result of the lease arrangement. The M/WBE does not receive credit for the total dollar value of the transportation services provided by the lessee since these services are not provided by an M/WBE.
 - f. A lease agreement with an M/WBE trucking firm must indicate that the M/WBE has exclusive use of and control over the truck. This does not preclude the leased truck from working for others during the term of the lease with the consent of the M/WBE, so long as the lease gives the M/WBE absolute priority for use of the leased truck. Leased trucks must display the name and identification number of the M/WBE.

E. Count expenditures with M/WBEs for materials and supplies toward M/WBE goals in the following manner:

- a. If the materials or supplies are obtained from an M/WBE manufacturer, count 100% of the cost of the materials or supplies toward M/WBE goals.

Note: For purposes of this paragraph (e)(a), a manufacturer is a firm that operates or maintains a factory or establishment that produces, on the premises, the materials, supplies, articles, or equipment required under the contract and of the general character described by the specifications.

- b. If the materials or supplies are purchased from an M/WBE regular dealer, count 60% of the cost of the materials or supplies toward M/WBE goals.

Note: For purposes of this section, a regular dealer is a firm that owns, operates or maintains a store, warehouse, or other establishment in which the materials, supplies, articles or equipment of the general character described by the specifications and required under the contract are brought, kept in stock, and regularly sold or leased to the public in the usual course of business.

- i. *To be a regular dealer, the firm must be an established, regular business that engages, as its principal business and under its own name, in the purchase and sale or lease of the products in question.*
- ii. *A person may be a regular dealer in such bulk items as petroleum products, steel, cement, gravel, stone, or asphalt without owning, operating, or maintaining a place of business as provided in this paragraph (E)(b), if the person both owns and operates distribution equipment for the products. Any supplementing of regular dealers' own distribution equipment shall be by a long-term lease agreement and not on an ad hoc or contract-by-contract basis.*
- iii. *Packagers, brokers, manufacturers' Representatives, or other persons who arrange or expedite transactions are not regular dealers within the meaning of the paragraph (E)(b).*

- c. If materials or supplies are purchased from an M/WBE which is neither a manufacturer nor a regular dealer, count only 5% of the contract amount toward the M/WBE goals.

VII. Record Keeping and Reporting

- A. The General Contractor agrees to maintain records demonstrative of its good faith efforts to comply with the participation goals attached to the project. This would include, but not limited to, names of M/WBEs and non-minority firms awarded subcontracts, including dollar amount of the contract, payments to subcontractors, and weekly certified payroll reports. These records shall be made available to the City of Peoria upon request.
- B. All information will be provided through ePrismSoft, an electronic web based compliance tracking software. Access to ePrismSoft has been furnished by the City of Peoria. To activate access, the General Contractor and subcontractors must contact Human Capital Development at webnfo@eprismsoft.com or 309/692-6400.

VIII. Sanctions

- A. The Equal Opportunity Office may recommend the rejection of the apparent low bid where the information submitted by the Apparent Low Bidder fails to objectively demonstrate compliance with the M/WBE Good-Faith Efforts requirements. The Apparent Low Bidder will be notified of this decision and the reasons in writing. The Apparent Low Bidder may request a hearing within five (5) business days of this notice. The request must be submitted to the Equal Opportunity Office. The hearing will be held no later than seven (7) business days after receipt of request. The City Manager or designee will conduct all hearings.
- B. Upon a finding that any party has not complied with the provisions of this clause, any one or a combination of the following actions may be taken:
 - a. Declare the Apparent Low Bidder non-responsive and therefore ineligible for contract award.
 - b. Declare the Apparent Low Bidder ineligible for further contracts for a calendar year.
 - c. File a formal complaint against Apparent Low Bidder, and/or subcontractor with the Fair Employment and Housing Commission.



MINORITY AND FEMALE WORKFORCE UTILIZATION

The City of Peoria is committed to ensuring our construction projects offer equal employment opportunity to all the citizens we serve. The Prime Contractor and all of its subcontractors are to make a good faith effort to comply with the following goals for minority and female workforce utilization.

1. Eighteen (18) percent of the total hours worked, per trade, should be performed by minority workers.
2. Three (3) percent of the total hours worked, per trade, should be performed by female workers.

Each contractor must maintain certified payroll records verifying the hours worked by minority and female workers. These records must be provided to the City of Peoria. For directions on submitting this information, see Minority and Women's Business Enterprise (M/WBE) Participation Requirements for Good-Faith Efforts, Section VII.



HUMAN RIGHTS ACT

The contract will be subject to and governed by the rules and regulations of the Illinois Human Rights Act, including Public Act 87-1257 (effective July 1, 1993) which requires that every bidder shall have a written sexual harassment policy that includes, at a minimum, the following information:

- a. The illegality of sexual harassment;
- b. The definition of sexual harassment under State law;
- c. A description of sexual harassment, utilizing examples;
- d. The bidder's internal complaint process including penalties;
- e. The legal recourse, investigative and complaint process available through the Illinois Department of Human Rights and the Illinois Human Rights Commission;
- f. Directions on how to contact the Department and the Commission;
- g. Protection against retaliation as provided in the Act.

Bidders are hereby placed on notice, a copy of its policy shall be provided to the Department upon request.

SAXI-93
effective 7-1-93
per Legal Dept.

APPENDIX A

EEO INFORMATION



MINORITY AND WOMEN BUSINESS ENTERPRISE DIRECTORY

To assist Bidders in their outreach efforts, the City of Peoria has developed a Minority and Women Business Enterprise (M/WBE) directory. Go to the City's website at www.peoriagov.org/equal-opportunity/minority-and-women-business-enterprise-mwbe-directory to view the directory.

EQUAL EMPLOYMENT OPPORTUNITY

To be awarded a contract all Suppliers, Vendors and Contractors to the City of Peoria must be registered in the City of Peoria's Contract Compliance Program and have a current EEO Certification Number. This program is unrelated to any State or Federal program. To obtain or renew a number, an Employer Report Form CC-1, a copy of your company's sexual harassment policy statement, if a first time applicant and a Fifty-dollar (\$50.00) processing fee must be submitted to the City of Peoria. Go to the City's website at www.ci.peoria.il.us/equal-opportunity-forms to obtain the form and instructions page.

Note: Suppliers, Vendors and Contractors do not need an EEO Certification Number to submit a bid proposal. However, it is required prior to the award of the contract.

CONTRACT DELIVERABLES



CITY OF PEORIA SUBCONTRACTOR PAYMENT FORM

PRIME CONTRACTOR

Name: _____
 Address: _____
 Phone: _____
 Contact Person: _____

PROJECT

Name: _____
 Pay Estimate No: _____
 Percent Complete: _____ %
 Work Period: _____ to _____

INSTRUCTIONS: Complete the table below. If additional space is needed attach extra pages as needed and included all information listed in the table below; along with project name and prime contractor.

Subcontractor <i>(Name)</i>	Payment Amount	Payment Type <i>(F-full/ P-partial)</i>
	\$	
	\$	
	\$	
	\$	
	\$	
	\$	
	\$	
Total Payment Amount for Work Completed	\$	

This form is to verify the work completed and the amount paid to a subcontractor utilized on the above listed project. Under penalty of law for perjury or falsification, the undersigned certifies that the payment reported herein was made to the subcontractors listed.

 Signature of Prime Contractor

 Date



CITY OF PEORIA MONTHLY WORKFORCE ANALYSIS

Check appropriate status

Month Ending _____

Contractor

Subcontractor

Name: _____

Address: _____

Contact Person: _____

Phone: _____

Project: _____

Date Work Started: _____

Percent Complete: _____ %

Job Categories	Number of Employees				Hours of Employment									
	Total # of Employees		Total Minorities		African American		Asian/Pacific Islander		American Indian/Alaskan Native		Hispanic		White	
	M	F	M	F	M	F	M	F	M	F	M	F	M	F
Foremen														
Electricians														
Glaziers														
Iron Workers														
Laborers														
Teamsters														
Millwrights														
Pipe Fitters														
Plumbers														
Plasterers														
Painters														
Roofers														
Operating Engs														
Tile Layers														
Sheet Metal Wkrs														
TOTALS														

Instructions: The total number of hours worked on the project (Hours of Employment), and the total number of individuals working on the project during the reporting period (Number of Employees) should be submitted on this form to the Project Resident Engineer every month. Each contractor and subcontractor should submit with this form certified payroll records for the period covered. The prime contractor is responsible for securing and submitting with his/her report, reports from all subcontractors.



CITY OF PEORIA NOTIFICATION OF CHANGE IN PARTICIPATION

Type of Change

Date: _____

_____ Subcontractor. Complete Part 1

_____ Self-Performance. Complete Part 2

PRIME CONTRACTOR

PROJECT

Name: _____

Name: _____

Address: _____

Phone: _____

PART 1

If changing from previously identified subcontractor to another, complete both From and To.

From Name _____

To Name _____

Address _____

Address _____

Phone _____

Phone _____

Status _____ MBE _____ WBE _____ Non-M/WBE

Status _____ MBE _____ WBE _____ Non-M/WBE

Contract Amount _____

Will scope of work change? _____ Yes _____ No

Describe change _____

Reason for Contractor Change _____

PART 2

Complete if deviating from intent to self-perform.

Prime Contractor will have to hire another contractor to perform work. _____ Yes _____ No

Change was due to _____ Emergency _____ Non-Emergency

Explain Situation _____

Describe good faith efforts to utilize M/WBE _____

Name of added Contractor _____

Address _____

Phone _____

Status _____ MBE _____ WBE _____ Non-M/WBE

Contract Amount _____

Scope of Work _____

Signed: _____

Contractor

Title

MISCELLANEOUS



CITY OF PEORIA
SAMPLE CONTRACT

This agreement, made and entered into this _____ day of _____, 201__, by and between the City of Peoria, an Illinois Municipal Corporation, Party of The First Part, and _____, Party of The Second Part for the improvement known as the _____;

WITNESSETH: That for and in consideration of the payments and agreements mentioned in the proposal hereto attached, to be made and performed by the Party of the First Part, and according to the terms expressed in the bond referring to these presents, the Party of The Second Part agrees with said Party of The First Part, at his/her/their own proper cost and expense to furnish and deliver all the work, materials and supplies in accordance with the specifications contained in said proposal, and in full compliance with all the terms of this agreement, for the amount of _____ (\$_____).

IT IS UNDERSTOOD AND AGREED that the instructions to bidders, proposal, bid, specifications, performance bond and maintenance bond are component parts of this contract and shall be deemed a part hereof. It is also understood and agreed that the contractor shall not assign, transfer, convey or otherwise dispose of this contract, or his/her right to execute it, or his/her right, title or interest in or to it or any part thereof, unless the previous written consent of the City Manager of the City of Peoria shall first be obtained thereto.

EMPLOYEE/EMPLOYMENT RESTRICTIONS – THE CONTRACTOR:

THE CONTRACTOR (hereinafter referred to as "SERVICE PROVIDER") agrees, as a condition of accepting this contract with the City of Peoria, that, for a period of one (1) year following completion of this contract, it shall be prohibited from hiring, directly or indirectly, any City employee or official who was involved, directly or indirectly in: (1) the selection and/or recommendation to select the SERVICE PROVIDER for performance of this contract; (2) coordinating the efforts of the SERVICE PROVIDER in the consummation or completion of this contract; or (3) monitoring or determining the performance of the SERVICE PROVIDER. The SERVICE PROVIDER further acknowledges and agrees that, upon the City's determination that a violation of this provision has occurred, the penalty imposed, at the sole discretion of the City, may include one or more of the following: (1) cancellation of any other contract(s) between the City of Peoria and the SERVICE PROVIDER; (2) disqualification of the SERVICE PROVIDER from bidding or being awarded future contracts with the City of Peoria for a period of two [2] years; and/or (3) payment of liquidated damages to the City of Peoria in the amount of TWENTY FIVE THOUSAND DOLLARS (\$25,000.00).

IN WITNESS WHEREOF, the said parties have executed these presents on the date above mentioned.
THE CITY OF PEORIA

BY: _____
City Manager

ATTEST: _____
City Clerk

EXAMINED AND APPROVED:

Corporation Counsel

PARTY OF THE SECOND PART

(name of individual, firm, or corporation)

BY: _____
(member of firm or officer of corporation)

(If a Co-Partnership)

(seal)
(seal)

Partners doing business under the firm name
of _____ (seal)
(Party of the second part)
(If an Individual)

(seal)
(Party of the second part)



CITY OF PEORIA
SAMPLE PERFORMANCE BOND

KNOW ALL MEN BY THESE PRESENTS, That I/we _____
an individual, of _____
a co-partnership, of _____
a corporation organized under the laws of the State of _____
as Principal, and _____
a corporation organized and existing under the laws of the State of _____ with
authority to do business in the State of Illinois, as Surety, are held and firmly bound unto the City of

Peoria, Peoria County, State of Illinois, in the penal sum of _____ Dollars
(\$ _____) lawful money of the United States, well and truly to be paid unto said City of
Peoria for the payment of which we bind ourselves, our heirs, executors, administrators, successors, and assigns,
jointly, severally, and firmly by these presents.

THE CONDITION OF THE FOREGOING OBLIGATIONS IS SUCH that whereas, the said Principal
has entered into a contract with the City of Peoria for NORTH WISCONSIN AVENUE ORNAMENTAL
LIGHTING (McCLURE AVENUE TO EAST REPUBLIC STREET) in accordance with the terms and
conditions of said contract, which is hereby referred to and made a part hereof as if fully set forth herein;

NOW, THEREFOR, the condition of this obligation is such, that if the above bounden Principal shall well and
truly keep, do and perform, each and every, all and singular, the matters and things in said contract set forth and
specified to be by said Principal kept, done and performed, at the times and in the manner in said contract
specified, or shall pay over, make good and reimburse the City of Peoria, all loss and damage which it may
sustain by reason of the failure or default on the part of the Principal so to do, then this obligation shall be null
and void; otherwise to remain in full force and effect.

IN WITNESS WHEREOF, we have duly executed the foregoing Obligation this _____ day of
_____, 201__.

FOR THE CITY OF PEORIA

Principal

EXAMINED AND APPROVED:

Corporation Counsel

Sureties

STATE OF _____)
) SS
COUNTY OF _____)

I, _____, a Notary Public in and for said County, in the State aforesaid, do hereby certify that _____, who is personally known to me to be the same person who signed the above foregoing instrument as the Attorney in Fact for _____, appeared before me this day in person and acknowledged that he/she signed the name of _____, thereto, as his/her Principal, and his/her own name as Attorney in Fact, as the free and voluntary act of his/her said Principal for the uses and purposes therein set forth, and that he/she executed the said instrument under authority given him/her by his/her said Principal.

Given under my hand and Notarial Seal, this _____ day of _____, 201__.

Notary Public



CONSTRUCTION DEBRIS MANIFEST

Ticket No.: _____

Contract No.: _____

Generator: _____

Hauler: _____

Truck

No.: _____

Description of
Material: _____

Approximate Weight of Material: _____

Approximate Volume of Material: _____

Disposition of Material:

Location:

Date: _____

Time: _____

Owner: _____

Operator: _____



SUBSTANCE ABUSE PREVENTION PROGRAM CERTIFICATION

Letting Date: _____ Item No.: _____

Contract No.: _____

Route: _____

Section: _____

Job No.: _____

County: _____

The Substance Abuse Prevention on Public Works Act, Public Act 95-0635, prohibits the use of drugs and alcohol, as defined in the Act, by employees of the Contractor and by employees of all approved Subcontractors while Performing work on a public works project. The Contractor/Subcontractor herewith certifies that it has a superseding collective bargaining agreement or makes the public filing of its written substance abuse prevention program for the prevention of substance abuse among its employees who are not covered by a collective bargaining agreement dealing with the subject as mandated by the Act.

A. The undersigned Representative of the Contractor/Subcontractor certifies that the contracting entity has signed collective bargaining agreements that are in effect for all of its employees, and that deal with the subject matter of Public Act 95-0635.

Contractor/Subcontractor

Name of Authorized Representative (type or print)

Title of Authorized Representative (type or print)

Signature of Authorized Representative

Date

B. The undersigned Representative of the Contractor/Subcontractor certifies that the contracting entity has in place for all of its employees not covered by a collective bargaining agreement that deals with the subject of the Act, the attached substance abuse prevention program that meets or exceeds the requirements of Public Act 95-0635.

Contractor/Subcontractor

Name of Authorized Representative (type or print)

Title of Authorized Representative (type or print)

Signature of Authorized Representative

Date

SUB-CONTRACTOR FINAL PAYMENT NOTIFICATION FORM

TAPE HERE

My firm has served as a subcontractor or supplier on contract # _____ . We request to be notified 30 days before the City intends to process papers for final payment on this contract.

We understand that it is a subcontractor or supplier's responsibility to ensure they are paid for a project and that notification provided by the Department is a courtesy only and does not provide any protection. We are aware of our rights to make a claim against the bond or file a lien against public funds in accordance with 30 ILCS 550 or 770 ILCS 60/23 and that this request constitutes neither action.

Date _____ Name _____

TAPE HERE

Postage
Stamp
Required

City of Peoria

Effective January 1, 1994 the Illinois Department of Transportation no longer requires prime contractors on highway construction projects to obtain release forms from subcontractors and suppliers. If you wish to be notified when final payment on a project will be made, please complete all of the shaded areas on this card, affix first class postage on both sides of the card, then fold the card so the City address is visible and mail the card. The card will be returned to you prior to the final payment being made on the contract.

If you would like more information on filing a lien or bond claim, IDOT publishes a booklet "Getting Paid" that is available from the district office. You may wish to consult with your attorney if you have specific legal questions concerning the state laws on liens and bond claims and your rights therein.

FOLD HERE

Your firm has served as a subcontractor or supplier on contract # _____. The City of Peoria plans to submit papers for processing of final payment to the prime contractor _____ during the next 30 days.

This information is provided as a courtesy only, pursuant to your request. This notification does not constitute an acknowledgment of a bond claim or a lien against public funds and does not guarantee payment.

Date prepared _____



Postage
Stamp
Required

Attn: _____

BC 2246 (Rev. 9/97)

INDEX OF SHEETS

C1	COVER SHEET
C2	GENERAL NOTES
C3	IMPROVEMENT PLAN
C4	DETAILS

CONTACT INFORMATION
KENT KOWALSKA Telephone#: (309) 677 5327
KENT KOWALSKA Telephone#: (309) 677 5327
MARIA ZAVALA Telephone#: (309) 272 4844
JANE GERDES Telephone#: (309) 494 8819
MATT WHITE Telephone#: (309) 208 8366
Telephone#: (630) 573 5450
KIRK KROMPHARDT Telephone#: (309) 686 2616
ENGINEERING OFFICE Telephone#: (309) 670 0400

-892-0123

RE LOCATED BY FIELD
 Y LOCATIONS WERE OBTAINED
 ARE APPROXIMATE AND
 E. BEFORE EXCAVATING.

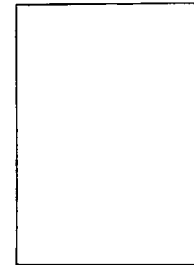

PUBLIC WORKS DEPARTMENT
 Engineering
 3505 N. Dries Ln.
 Peoria, IL 61604
 PH 309-694-8800
 FAX 309-694-8655
 www.peoriagov.org



REVISIONS			
NO.	DATE	BY	DESCRIPTION
Δ			

AUSTIN ENGINEERING, CO., INC.
 Consulting Engineers / Surveyors
 311 SW Water St., Suite 215
 Peoria, Illinois 61602
 License No. 164-001143

DATE:	06.17.16
DRAWN BY:	SDR
APPRD:	DLB
CLIENT:	COP

SHEET TITLE
COVER

SHEET NO.
C-1

JOB NO.
 20-16-003

GENERAL NOTES

1. FOR INFORMATION RELATED TO EXISTING SURVEY; THE BASE PROJECT INFORMATIONAL PURPOSES ONLY. IT IS THE RESPONSIBILITY OF THE ENGINEER TO VERIFY ALL SITE CONDITIONS.
2. ALL WORK HEREIN PROPOSED SHALL BE COMPLETED IN ACCORDANCE WITH THE SPECIFICATIONS FOR PROPRIETARY APPLICABLE FEDERAL, STATE AND LOCAL LAWS, CODES, REGULATIONS AND ORDINANCES.

3. ALL WORK AND MATERIALS WHICH DO NOT CONFORM TO THE SPECIFICATIONS SHALL BE REMOVED AND REPLACEMENT AT THE CONTRACTOR'S EXPENSE.
4. MINIMUM FORTY-EIGHT (48) HOURS (EXCLUDING SATURDAY, SUNDAY AND HOLIDAYS) BEFORE STARTING EXCAVATION, EACH CONTRACTOR SHALL NOTIFY THE CITY ENGINEER AT (800) 741-5000 TO HAVE THE LOCATION OF EXISTING UTILITIES STAKED.
5. ALL REQUESTS FOR CLARIFICATION OR ADDITIONAL INFORMATION DURING CONSTRUCTION METHODS OR ITEMS OR EQUIPMENT PRIOR TO BID SHALL BE SUBMITTED TO THE CITY ENGINEER WHO WILL FURNISH IN WRITING INFORMATION OR CLARIFICATIONS. ANY DISCREPANCIES BETWEEN THE PLANS, QUANTITIES, OR SPECIFICATIONS DISCOVERED BY THE CONTRACTOR, EITHER PRIOR TO OR AFTER THE AWARD OF THE CONTRACT, SHALL BE BROUGHT TO THE CITY ENGINEER'S ATTENTION BEFORE WORK HAS BEGUN. THE PROPER CORRECTIONS CAN BE MADE.
6. NOTIFY THE UTILITY OWNER AND CITY ENGINEER IMMEDIATELY OF ANY INTERFERENCE BETWEEN EXISTING AND PROPOSED UTILITIES.
7. THE CONTRACTOR IS SOLELY RESPONSIBLE FOR THE DESIGN, CONSTRUCTION AND REMOVAL OF ALL NON-PERMANENT CONSTRUCTION. THE CONTRACTOR SHALL MAINTAIN EXISTING OPERATING CONDITIONS DURING CONSTRUCTION.
8. THE CONTRACTOR MUST REPAIR OR REPLACE EXISTING CONDITIONS DURING CONSTRUCTION BY, OR RELATED TO, CONSTRUCTION ACTS ADDITIONAL COST TO THE OWNER. RESTORATION OF DAMAGE TO PRIVATE PROPERTY OUTSIDE THE LIMITS OF CONSTRUCTION AS SHOWN SHALL BE COMPLETED IN ACCORDANCE WITH THE PROJECT SPECIFICATIONS. APPLICABLE SECTIONS OF THE STANDARD SPECIFICATIONS FOR ROAD CONSTRUCTION, ILLINOIS DEPARTMENT OF TRANSPORTATION, LATEST EDITION, SHALL BE USED FOR RESTORATION OF TRANSPORTATION, LANE WIDTHS, DITCHES, BUSHES, HEDGES, TREES, SHRUBS, SEWERS, WATER MAINS, ETC.
9. ALL DISTURBED LANDSCAPED AREAS DUE TO PROPOSED CONSTRUCTION SHALL BE RESTORED TO ORIGINAL CONDITION, BUT NOT LESS THAN ORIGINAL CONDITION OR BETTER, AND SHALL INCLUDE, AS POSSESSED BY THE OWNER. THESE AREAS SHALL BE RESTORED AS NEARLY AS POSSIBLE TO ORIGINAL CONDITION. RESTORATION SHALL BE PERFORMED BY THE CONTRACTOR AT HIS/HER OWNERS RISK AND SHALL BE RESTORED TO ORIGINAL CONDITION. RESTORATION OF MAINTAINED LAWNS, RIGHT-OF-WAY, ROADWAYS, SIDEWALKS, DITCHES, BUSHES, HEDGES, TREES, SHRUBS, SEWERS, WATER MAINS, ETC.
10. ALL DISTURBED LANDSCAPED AREAS DUE TO PROPOSED CONSTRUCTION SHALL BE RESTORED TO ORIGINAL CONDITION, BUT NOT LESS THAN ORIGINAL CONDITION OR BETTER, AND SHALL INCLUDE, AS POSSESSED BY THE OWNER. THESE AREAS SHALL BE RESTORED AS NEARLY AS POSSIBLE TO ORIGINAL CONDITION. RESTORATION SHALL BE PERFORMED BY THE CONTRACTOR AT HIS/HER OWNERS RISK AND SHALL BE RESTORED TO ORIGINAL CONDITION. RESTORATION OF MAINTAINED LAWNS, RIGHT-OF-WAY, ROADWAYS, SIDEWALKS, DITCHES, BUSHES, HEDGES, TREES, SHRUBS, SEWERS, WATER MAINS, ETC.
11. THE CONTRACTOR SHALL MAINTAIN ROADWAYS ADJOINING THE PROJECT AND SHALL MAINTAIN THE FULL EXTENT OF THE CONTRACT WHICH WOULD BE REQUIRED BY THE JURISDICTION, TEMPORARY TRAFFIC, PARKING SIGNAGE, AND PERSONNEL NECESSARY TO PROVIDE FOR SAFE AND UNINTERRUPTED TRAFFIC FLOW IN ALL AREAS WHERE THE WORK WILL INTERRUPT TRAFFIC FLOW. THE CONTRACTOR TO FURNISH TRAFFIC CONTROL UNDER ANY CIRCUMSTANCES WHERE, IN HIS OPINION, IT IS NECESSARY FOR THE PROTECTION OF LIFE AND PROPERTY. THE NEED FOR TRAFFIC CONTROL SHALL BE DETERMINED BY THE CONTRACTOR. ALL WORK SHALL BE PERFORMED ACCORDING TO STANDARD SPECIFICATIONS & STANDARD SPECIFICATIONS FOR ROAD CONSTRUCTION, ILLINOIS DEPARTMENT OF TRANSPORTATION, LATEST EDITION.

NO.	DATE	DESCRIPTION	BY



NO.	DATE	DESCRIPTION	BY

CITY OF PEORIA

PUBLIC WORKS DEPARTMENT

Engineering
3505 N. Dimes Ln.
Peoria, IL 61604
PH 309-494-8900
FAX 309-494-8855
www.peoriagov.org

AUSTIN ENGINEERING CO., INC.
Consulting Engineers / Surveyors
311 SW Water St., Suite 215
Peoria, Illinois 61602
License No. 184-007143

DATE: 08.17.16

DRAWN BY: SDR

APPRD: DLB

CLIENT: COP

SHEET TITLE: NOTES

SHEET NO.: C-2

JOB NO.: 20-16-003

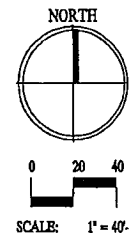
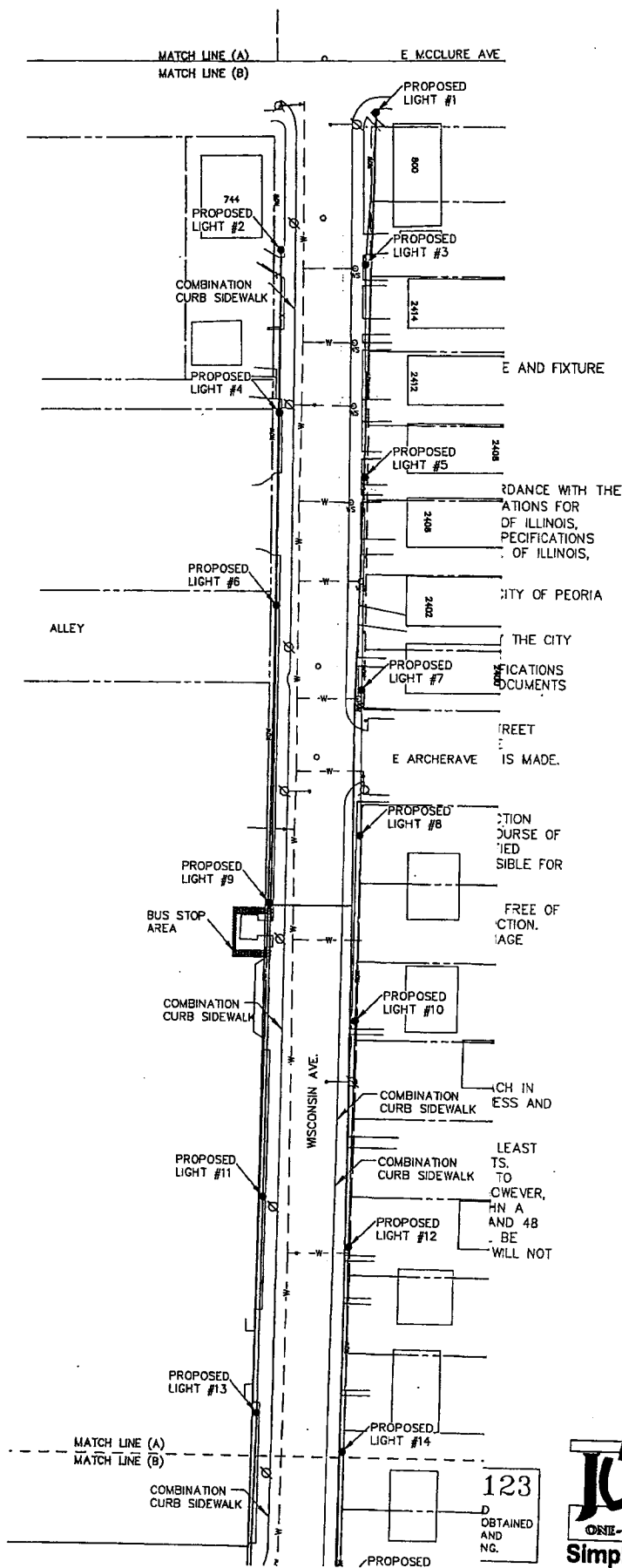

PUBLIC WORKS DEPARTMENT
 Engineering
 3505 N. Drees Ln.
 Peoria, IL 61604
 PH 309-494-8800
 FAX 309-494-8855
 www.peoriagoov.org



REVISIONS			
NO.	DATE	BY:	DESCRIPTION
1			

AUSTIN ENGINEERING, CO., INC.
 Consulting Engineers / Surveyors
 3111 Sullivan Ave #215
 Peoria, Illinois 61602
 License No. 194-001143

DATE:	06.17.16
DESIGN:	
DRAWN BY:	SDR
APPRD:	DLB
CLIENT:	COP
SHEET TITLE	
IMPROVEMENT	
SHEET NO.	
C-3	
JOB NO.	
20-16-003	

Call Before You Dig

JULIE
 ILLINOIS
 ONE-CALL SYSTEM
 Simply Call 811

123
 D OBTAINED AND NG.

CONSTRUCTION PLANS FOR NORTH WISCONSIN AVE ORNAMENTAL LIGHTING (MCLURE AVE. TO EAST REPUBLIC STREET) PEORIA ILLINOIS

INDEX OF SHEETS
 C1 COVER SHEET
 C2 GENERAL NOTES
 C3 IMPROVEMENT PLAN
 C4 DETAILS

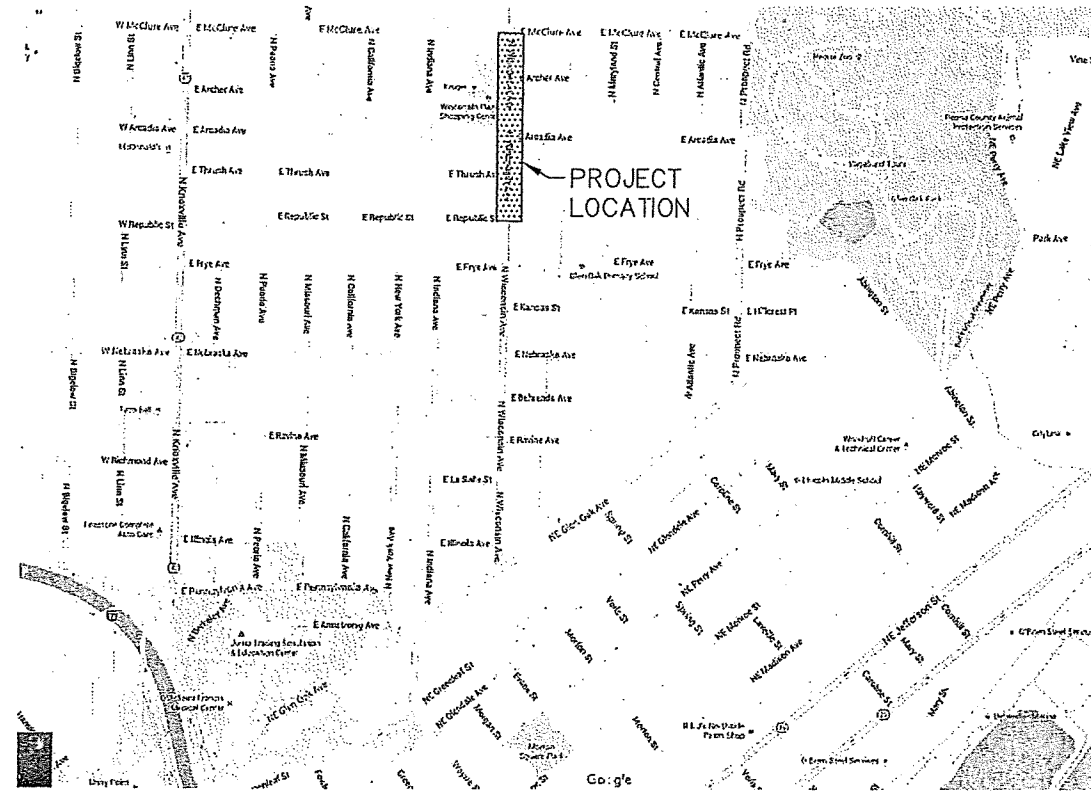

LOCATION MAP
(NOT TO SCALE)

APPROVED
 CITY OF PEORIA
 BY: *[Signature]*
 DATE: 7/13/16

AUSTIN ENGINEERING CO., INC.
 PEORIA, ILLINOIS
 BY: *[Signature]*
 DEVIN L. BIRCH, P.E.
 DATE: 7/12/16



UTILITY	UTILITY OWNER	CONTACT INFORMATION
POWER	CILCO AMEREN	KENT KOWALSKIE Telephone#: (309) 677 5327
NATURAL GAS	CILCO AMEREN	KENT KOWALSKIE Telephone#: (309) 677 5327
SANITARY	GREATER PEORIA SANITARY DISTRICT	MARIA ZAVALA Telephone#: (309) 272 4844
STORM	CITY OF PEORIA PUBLIC WORKS	JANE GERDES Telephone#: (309) 494 8819
WATER	ILLINOIS AMERICAN WATER CO. - PEORIA	MATT WHITE Telephone#: (309) 208 8366
CABLE/ PHONE	AT&T	Telephone#: (630) 573 5450
CABLE/ PHONE	COMCAST	KIRK KROMPHARDT Telephone#: (309) 686 2616
CABLE/ PHONE	ITV-3, INC.	ENGINEERING OFFICE Telephone#: (309) 670 0400

J.U.L.I.E. 1-800-892-0123

NOTE: VISIBLE UTILITY STRUCTURES WERE LOCATED BY FIELD SURVEY AS SHOWN. UNDERGROUND UTILITY LOCATIONS WERE OBTAINED FROM AVAILABLE RECORD DRAWINGS AND ARE APPROXIMATE AND MAY NOT BE COMPLETE. CONTACT J.U.L.I.E. BEFORE EXCAVATING.

PUBLIC WORKS DEPARTMENT
 Engineering
 3505 N. Diles Ln.
 Peoria, IL 61604
 PH 309-494-8900
 FAX 309-494-8955
 www.peoriagov.org

REVISIONS			
NO.	DATE	BY	DESCRIPTION
1			

AUSTIN ENGINEERING CO., INC.
 Consulting Engineers / Surveyors
 311 SW Water St., Suite 216
 Peoria, IL 61602
 License No. 164-001143

DATE: 06.17.16

DRAWN BY: SDR
 APPRD: DLB
 CLIENT: COP

SHEET TITLE
COVER

SHEET NO.
C-1

JOB NO.
 20-16-003

GENERAL NOTES

- FOR INFORMATION RELATED TO EXISTING SURVEY: THE BASE PROVIDED IS FOR INFORMATIONAL PURPOSES ONLY. IT IS THE RESPONSIBILITY OF THE CONTRACTOR TO VERIFY ALL SITE CONDITIONS.
- ALL WORK HEREIN PROPOSED SHALL BE COMPLETED IN ACCORDANCE WITH THE APPLICABLE FEDERAL, STATE AND LOCAL LAWS, CODES, REGULATIONS AND PERMITS. THE CONTRACTOR SHALL BE RESPONSIBLE FOR OBTAINING ALL REQUIRED PERMITS AND PAYING THE REQUISITE FEES FOR CONSTRUCTION. HE/SHE SHALL BE RESPONSIBLE FOR ANY DAMAGE TO THE STREETS OR ROADWAYS AND ASSOCIATED STRUCTURES AND SHALL MAKE REPAIRS AS NECESSARY TO THE SATISFACTION OF THE CITY ENGINEER.
- ALL WORK AND MATERIALS WHICH DO NOT CONFORM TO THE SPECIFICATIONS ARE SUBJECT TO REMOVAL AND REPLACEMENT AT THE CONTRACTOR'S EXPENSE.
- MINIMUM FORTY-EIGHT (48) HOURS (EXCLUDING SATURDAY, SUNDAY AND HOLIDAYS) BEFORE STARTING EXCAVATION, EACH CONTRACTOR SHALL CALL J.U.L.E. AT (800) 741-5000 TO HAVE THE LOCATION OF EXISTING UNDERGROUND UTILITIES STAKED.
- ALL REQUESTS FOR CLARIFICATION OR ADDITIONAL INFORMATION RELATIVE TO CONSTRUCTION METHODS OR ITEMS OR EQUIPMENT PRIOR TO BIDDING SHALL BE DIRECTED TO THE CITY ENGINEER WHO WILL FURNISH IN WRITING SUCH INFORMATION OR CLARIFICATION REQUIRED. ANY DISCREPANCIES OR CONFLICTS ON THE PLANS, QUANTITIES, OR SPECIFICATIONS, DISCOVERED BY THE CONTRACTOR, EITHER PRIOR TO OR AFTER THE AWARD OF THE CONTRACT SHALL BE BROUGHT TO THE CITY ENGINEER'S ATTENTION BEFORE WORK HAS BEGUN SO THAT THE PROPER CORRECTIONS CAN BE MADE.
- NOTIFY THE UTILITY OWNER AND CITY ENGINEER IMMEDIATELY OF ANY CONFLICTS OR INTERFERENCE BETWEEN EXISTING AND PROPOSED UTILITIES.
- THE CONTRACTOR IS SOLELY RESPONSIBLE FOR THE DESIGN, CONSTRUCTION, INSTALLATION AND REMOVAL OF ALL NON-PERMANENT CONSTRUCTIONS NECESSARY TO EXECUTE THE WORK, INCLUDING BUT NOT LIMITED TO SHORING. DESIGN MUST BE DONE IN A WAY TO MAINTAIN EXISTING OPERATING CONDITIONS AT ALL TIMES DURING CONSTRUCTION.
- THE CONTRACTOR MUST REPAIR OR REPLACE EXISTING CONDITIONS DAMAGED DURING CONSTRUCTION BY, OR RELATED TO, CONSTRUCTION ACTIVITIES, AT NO ADDITIONAL COST TO THE OWNER. RESTORATION OF DAMAGE TO PUBLIC OR PRIVATE PROPERTY OUTSIDE THE LIMITS OF CONSTRUCTION AS SHOWN ON PLANS SHALL BE COMPLETED IN ACCORDANCE WITH THE PROJECT SPECIFICATIONS AND APPLICABLE SECTIONS OF THE STANDARD SPECIFICATIONS FOR ROAD AND BRIDGE CONSTRUCTION, ILLINOIS DEPARTMENT OF TRANSPORTATION, LATEST EDITION. SUCH RESTORATION SHALL BE PERFORMED BY THE CONTRACTOR AT NO COST TO THE OWNER. THESE AREAS SHALL BE RESTORED AS NEARLY AS POSSIBLE TO THEIR ORIGINAL CONDITION OR BETTER, AND SHALL INCLUDE, BUT NOT LIMITED TO RESTORATION OF MAINTAINED LAWNS, RIGHT-OF-WAY, ROADWAYS, DRIVEWAYS, SIDEWALKS, DITCHES, BUSHES, HEDGES, TREES, SHRUBS, SEWERS, DRAIN TILES, WATER MAINS, ETC.
- ALL DISTURBED LANDSCAPED AREAS DUE TO PROPOSED CONSTRUCTION SHALL BE PROVIDED WITH SIX INCHES (6") OF TOPSOIL AND SOD. THE CONTRACTOR SHALL IRRIGATE THE SOD FOR MINIMUM OF TWO WEEKS.
- ALL DIMENSIONS ARE FROM END OF SIDEWALK, CENTER OF FOUNDATION, FACE OF BUILDING, BACK OF CURB, OR PROPERTY LINE UNLESS OTHERWISE NOTED.
- THE CONTRACTOR SHALL MAINTAIN ROADWAYS ADJOINING THE PROJECT SITE FREE FROM MUD AND DEBRIS AT ALL TIMES. IF MUD AND/OR DEBRIS IS/ARE CARRIED ONTO THE ROADWAYS FROM EITHER THE CONTRACTOR'S TRUCKS, HIS/HER EMPLOYEES VEHICLES, OR HIS/HER MATERIAL SUPPLIERS, THE CONTRACTOR SHALL IMMEDIATELY REMOVE SAID MUD AND/OR DEBRIS. ALL WORK PERFORMED BY THE CONTRACTOR SHALL BE GUARANTEED BY THE CONTRACTOR FOR A PERIOD OF TWELVE MONTHS FROM THE DATE OF FINAL ACCEPTANCE. THIS GUARANTEE SHALL INCLUDE ALL DEFECTS IN MATERIALS AND WORKMANSHIP.
- THE CONTRACTOR SHALL DEFEND, INDEMNIFY, KEEP AND SAVE HARMLESS THE CITY OF PEORIA, OWNER AND ENGINEER, AND THEIR RESPECTIVE BOARD MEMBERS, REPRESENTATIVES, AGENTS AND EMPLOYEES, IN BOTH INDIVIDUAL AND OFFICIAL CAPACITIES, AGAINST ALL SUITS, CLAIMS, DAMAGES, LOSSES AND EXPENSES, INCLUDING ATTORNEY'S FEES, CAUSED BY, GROWING OUT OF, OR INCIDENTAL TO THE PERFORMANCE OF THE WORK UNDER THE CONTRACT BY THE CONTRACTOR OR ITS SUBCONTRACTORS TO THE FULL EXTENT AS ALLOWED BY THE LAWS OF THE STATE OF ILLINOIS AND NOT BEYOND ANY EXTENT WHICH WOULD RENDER THESE PROVISIONS VOID OR UNENFORCEABLE. THE CONTRACTOR MUST PROVIDE, AS REQUIRED BY THE JURISDICTION, TEMPORARY TRAFFIC, PARKING SIGNAGE, EQUIPMENT, AND PERSONNEL NECESSARY TO PROVIDE FOR SAFE AND EFFICIENT TRAFFIC FLOW IN ALL AREAS WHERE THE WORK WILL INTERRUPT IN ANY FORM, THE CONDITIONS OF TRAFFIC FLOW THAT EXISTED PRIOR TO THE COMMENCEMENT OF ANY PORTIONS OF THE WORK. THE CITY ENGINEER MAY, AT HIS/HER DISCRETION, REQUIRE THE CONTRACTOR TO FURNISH TRAFFIC CONTROL UNDER OTHER CIRCUMSTANCES WHERE, IN HIS OPINION, IT IS NECESSARY FOR THE PROTECTION OF LIFE AND PROPERTY. THE NEED FOR TRAFFIC CONTROL SHALL BE ANTICIPATED BY THE CONTRACTOR. ALL WORK SHALL BE PERFORMED ACCORDING TO THE PROJECT SPECIFICATIONS & STANDARD SPECIFICATIONS FOR ROAD AND BRIDGE CONSTRUCTION, ILLINOIS DEPARTMENT OF TRANSPORTATION, LATEST EDITION.

- THE CONTRACTOR SHALL PROVIDE SAFE PEDESTRIAN ACCESS TO ADJACENT PROPERTIES AS REQUIRED BY THE CITY OF PEORIA.
- ALL DEBRIS AND SPOILS RESULTING FROM CONTRACTOR'S WORK ARE TO BE REMOVED FROM THE JOB SITE OR PLACED IN A RECEPTACLE PROVIDED BY THE CONTRACTOR IN A TIMELY FASHION OR AS REQUESTED BY THE CITY.
- THE CONTRACTOR SHALL TAKE ALL NECESSARY STEPS TO PROTECT RESIDENTS, THE PUBLIC AND THE SITE FROM DAMAGE OR INJURY. THIS SHALL BE COORDINATED WITH THE PROPERTY OWNERS AND THE CITY OF PEORIA.

DEMOLITION NOTES

- THE EXTENT OF DEMOLITION WORK IS INDICATED ON THE DRAWINGS AND SPECIFIED HEREIN AND INCLUDES, BUT IS NOT LIMITED TO THE REMOVAL OF SIDEWALK, PAVING, VEGETATION AND OTHER SITE FEATURES WHICH CONFLICT WITH THE CONSTRUCTION OF THE NEW FACILITIES, OR ARE DESIGNATED TO BE REMOVED.
- THE CONTRACTOR SHALL CONDUCT DEMOLITION OPERATIONS AND REMOVAL OF DEBRIS AND SPOILS TO ENSURE MINIMAL INTERFERENCE WITH RESIDENTIAL OPERATIONS.
- THE CONTRACTOR SHALL ENSURE SAFE PASSAGE OF PERSONS AROUND AREAS OF DEMOLITION. REMOVE FROM SITE ALL DEBRIS, RUBBISH AND OTHER MATERIALS RESULTING FROM DEMOLITION AND LAWFULLY DISPOSE OF SAME.
- THE CONTRACTOR SHALL NOTIFY UTILITY OWNER, LOT OWNER AND CITY ENGINEER 48 HOURS IN ADVANCE OF ANY UTILITY SHUTDOWN.
- THE CONTRACTOR SHALL COORDINATE WITH THE UTILITY OWNER ALL ITEMS DESIGNATED TO BE REMOVED.
- IF ANY ITEMS ARE ENCOUNTERED IN THE FIELD THAT ARE NOT SHOWN ON THE PLAN WHICH REQUIRE DEMOLITION OR RELOCATION, THE CONTRACTOR SHALL NOTIFY THE CITY ENGINEER IMMEDIATELY.
- THE CONTRACTOR SHALL PROTECT ALL THE UTILITIES DESIGNATED TO REMAIN. ANY DAMAGE BY THE CONTRACTOR TO UTILITIES, STREETS OR ADJACENT PROPERTIES WILL BE REPLACED/REPAIRED AT THE CONTRACTOR'S EXPENSE.
- THE CONTRACTOR SHALL TAKE EVERY PRECAUTION TO PROTECT AGAINST SETTLEMENTS, MOVEMENTS, AND ANY DAMAGE TO ADJACENT STRUCTURES. CONTRACTOR SHALL BE HELD RESPONSIBLE FOR ANY DAMAGE CAUSED TO ADJACENT STRUCTURES DURING CONSTRUCTION OR DEMOLITION. ANY REPAIR OR REPLACEMENTS SHALL BE ENTIRELY AT THE CONTRACTOR'S EXPENSE.

UTILITY NOTE

- THE LOCATIONS OF THOSE BURIED AND ABOVE GROUND UTILITIES SHOWN ARE APPROXIMATE AND ARE SHOWN FOR CONTRACTOR INFORMATION ONLY. THEY ARE NOT TO BE REFERENCED FOR CONSTRUCTION PURPOSES. THE IMPLIED PRESENCE OR ABSENCE OF UTILITIES IS NOT CONSTRUED BY THE OWNER, ENGINEER, CONTRACTOR, OR SUBCONTRACTORS TO BE AN ACCURATE AND COMPLETE REPRESENTATION OF UTILITIES THAT MAY OR MAY NOT EXIST ON THE CONSTRUCTION SITE. BURIED OR ABOVE GROUND UTILITY LOCATION, IDENTIFICATION, AND MARKING ARE THE SOLE RESPONSIBILITY OF THE CONTRACTOR. REROUTING, DISCONNECTION, PROTECTION, ETC. OF ANY UTILITIES MUST BE COORDINATED BETWEEN THE CONTRACTOR AND THE UTILITY OWNER. SITE SAFETY, INCLUDING THE AVOIDANCE OF HAZARDS ASSOCIATED WITH BURIED AND ABOVE GROUND UTILITIES, REMAIN THE SOLE RESPONSIBILITY OF THE CONTRACTOR.

EROSION CONTROL NOTES

- THE SEDIMENTATION AND EROSION CONTROL MEASURES SHALL BE IN ACCORDANCE WITH THE STANDARDS AND SPECIFICATIONS FOR SOIL AND SEDIMENTATION CONTROL OF LOCAL GOVERNMENT AGENCIES, PROCEDURES AND STANDARDS FOR URBAN SOIL AND SEDIMENTATION CONTROL IN ILLINOIS, AND IEPA STANDARDS AND SPECIFICATIONS FOR SOIL EROSION AND SEDIMENT CONTROL, LATEST EDITION.
- PRIOR TO COMMENCING LAND-DISTURBING ACTIVITIES IN AREAS OTHER THAN INDICATED ON THESE PLANS, A EROSION CONTROL PLAN SHALL BE SUBMITTED TO THE ENGINEER FOR REVIEW.
- THE CONTRACTOR IS RESPONSIBLE FOR THE PROPER INSTALLATION AND MAINTENANCE OF ALL EROSION CONTROL DEVICES. THE CONTRACTOR IS ALSO RESPONSIBLE FOR INSTALLATION OF ANY ADDITIONAL EROSION CONTROL MEASURES NECESSARY TO PREVENT EROSION AND SEDIMENTATION AS DETERMINED BY THE ENGINEER.
- SEE IMPROVEMENT PLAN FOR CONDUIT/LIGHTING LOCATIONS

- DURING ANY DEWATERING OPERATIONS, WATER WILL BE PUMPED INTO SEDIMENT BASINS OR SILT TRAPS. DEWATERING DIRECTLY INTO THE FIELD TILES OR STORM SEWER IS PROHIBITED.
- PERMANENT OR TEMPORARY SOIL STABILIZATION MUST BE APPLIED WITHIN 15 CALENDAR DAYS OF THE END OF ACTIVE SOIL DISTURBANCE.
- FILTER BASKETS SHALL BE INSTALLED AND MAINTAINED AROUND INLET STRUCTURES.
- SEDIMENTATION BASINS, BARRIERS, AND ALL APPROPRIATE EROSION CONTROL MEASURES SHALL BE INSTALLED PRIOR TO ANY START OF SITE DISTURBING.
- THE CONTRACTOR SHALL INSPECT EROSION CONTROL MEASURES WEEKLY AND AFTER ANY STORM EVEN IN EXCESS OF 1/2".
- SHOULD THE VOLUME, VELOCITY, SEDIMENT LOAD, OR PEAK FLOW RATES OF STORMWATER RUNOFF TEMPORARILY INCREASE DURING CONSTRUCTION, THEN ADDITIONAL MEASURES TO PROTECT ADJACENT PROPERTIES SHALL BE UNDERTAKEN.
- THE TEMPORARY EROSION MEASURES SHALL REMAIN IN PLACE UNTIL ALL THE PERMANENT EROSION CONTROL ITEMS ARE FULLY FUNCTIONAL.
- GRAVELED ROADS, ACCESS DRIVES, PARKING AREAS OF SUFFICIENT WIDTH AND LENGTH, AND VEHICLES WASHDOWN FACILITIES, SHALL BE PROVIDED TO PREVENT THE DEPOSIT OF SOIL FROM BEING TRACKED ONTO PUBLIC OR PRIVATE ROADWAY. ANY SOIL REACHING A PUBLIC OR PRIVATE ROADWAY SHALL BE REMOVED CONTINUOUSLY.
- DUST SCREENING SHALL BE PROVIDED ON ALL CONSTRUCTION FENCING.

DESIGN STANDARDS

- STANDARD SPECIFICATIONS FOR ROAD AND BRIDGE DESIGN, PUBLISHED BY IDOT, APRIL 2016 .
- SUPPLEMENTAL SPECIFICATIONS AND RECURRING SPECIAL PROVISIONS, PUBLISHED BY IDOT, APRIL 2016 .
- MANUFACTURER SPECIFICATIONS AND RECOMMENDATIONS FOR PROPRIETARY PRODUCTS DETERMINED TO BE USED FOR THIS PROJECT.
- NATIONAL ELECTRICAL CODE 2011.

SUMMARY OF QUANTITIES

ITEM DESCRIPTION	QUANTITY	UNIT
TRAFFIC CONTROL AND PROTECTION	1	L. SUM
REMOVAL AND DISPOSAL OF UNSUITABLE MATERIALS	30	CY
CONCRETE HANDHOLE	2	L. SUM
CONDUIT (2")	2860	FOOT
PORTLAND CEMENT CONCRETE SIDEWALK	100	SF
LIGHT POLE FOUNDATION	25	EACH
LIGHT POLE, DECORATIVE	25	EACH
ELCBL, IN CONDUIT, 600V XLP, 1/C, NO. 6 GREEN	3550	FOOT
ELCBL, IN CONDUIT, 600V XLP, 1/C, NO. 6 BLACK	7100	FOOT

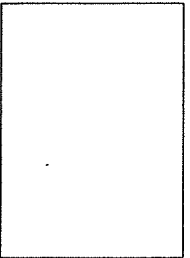

PUBLIC WORKS DEPARTMENT
 Engineering
 3505 N. Diles Ln.
 Peoria, IL 61604
 PH 309-684-8800
 FAX 309-684-8855
 www.peoriagov.org

REVISIONS			
NO.	DATE	BY	DESCRIPTION
Δ			

AUSTIN ENGINEERING, CO., INC.
 Consulting Engineers / Surveyors
 311 S. Water St., Suite 215
 Peoria, IL 61603
 License No. 184-01143

DATE:	06.17.16
DRAWN BY:	SDR
APPRD:	DLB
CLIENT:	COP

SHEET TITLE
NOTES

SHEET NO. C-2
JOB NO. 20-16-003

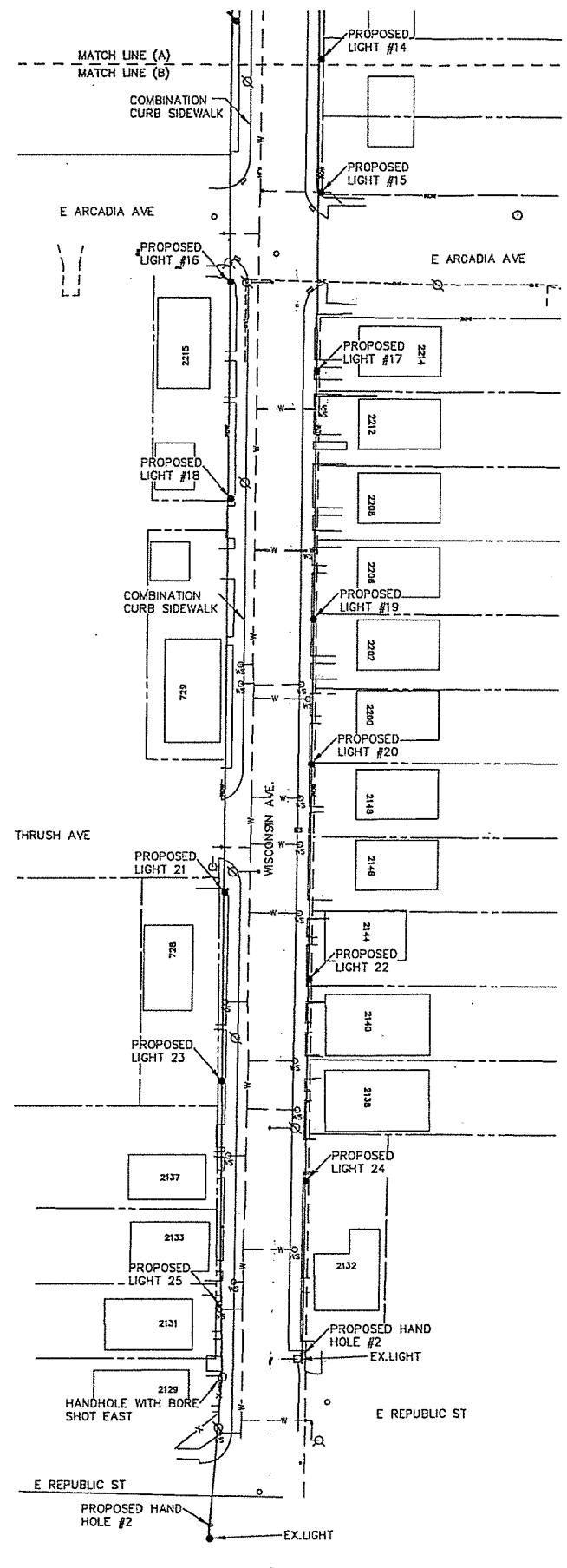
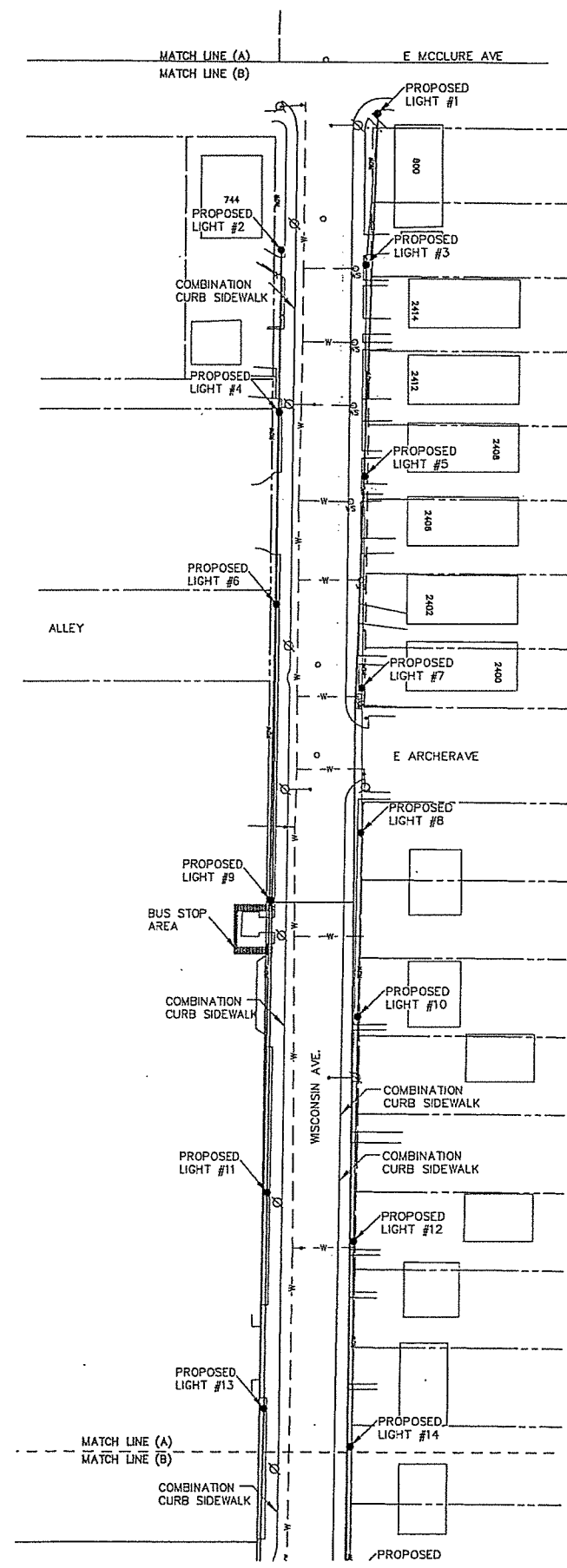

- LEGEND**
- BOUNDARY LINE
 - ROW LINE
 - W- EXISTING WATER MAIN
 - OH- EXISTING OVERHEAD ELECTRIC
 - G- EXISTING GAS MAIN
 - PROPOSED ELECTRIC CONDUIT
 - EXISTING LIGHT POST
 - * ○ EXISTING LIGHT POST
 - WS EXISTING WATER SERVICE
 - EXISTING FIRE HYDRANT
 - EXISTING ELECTRIC POWER POLE
 - PROPOSED NEW STANDARD LIGHT POLE AND FIXTURE

GENERAL NOTES:

1. ALL CONSTRUCTION SHALL BE PERFORMED IN ACCORDANCE WITH THE APPLICABLE PORTIONS OF "THE STANDARD SPECIFICATIONS FOR ROAD AND BRIDGE CONSTRUCTION", OF THE STATE OF ILLINOIS, ADOPTED APRIL 1, 2016 AND THE SUPPLEMENTAL SPECIFICATIONS AND RECURRING SPECIAL PROVISIONS OF THE STATE OF ILLINOIS, ADOPTED APRIL 1, 2016.
2. FINAL LIGHT LOCATIONS TO BE APPROVED BY THE CITY OF PEORIA
3. ALL WORK IS SUBJECT TO PERIODIC INSPECTIONS BY THE CITY OF PEORIA AS CONSTRUCTION PROGRESSES, AS PER CONSTRUCTION INSPECTION AND ACCEPTANCE SPECIFICATIONS OUTLINED IN THE SPECIFICATIONS AND CONTRACT DOCUMENTS FOR THIS PROJECT.
4. FINAL ACCEPTANCE BY THE CITY OF PEORIA FOR STREET IMPROVEMENTS IS BASED ON THE CONDITION OF THE IMPROVEMENTS AT THE TIME THE FINAL INSPECTION IS MADE.
5. THE CONTRACTOR SHALL BE RESPONSIBLE FOR THE PROTECTION OF ALL UTILITIES WITHIN THE CONSTRUCTION LIMITS. IF ANY UTILITY IS DAMAGED DURING THE COURSE OF CONSTRUCTION, THE UTILITY OWNER SHALL BE NOTIFIED IMMEDIATELY. THE CONTRACTOR SHALL BE RESPONSIBLE FOR ANY EXPENSES INCURRED TO REPAIR THE UTILITY.
6. DRAINAGE AND STORM STRUCTURES SHALL BE KEPT FREE OF DEBRIS AND DIRT DURING THE COURSE OF CONSTRUCTION. CONTRACTOR SHALL BE RESPONSIBLE FOR ANY DAMAGE CAUSED BY ANY STORM SEWER BACKUPS.

TRAFFIC NOTES:

1. FLASHING LIGHTS SHALL BE USED ON EACH APPROACH IN ADVANCE OF WORK AREA DURING HOURS OF DARKNESS AND PLACED ON EACH PERMANENT SIGN.
2. EVERY EFFORT SHALL BE MADE TO ALLOW FOR THE LEAST AMOUNT OF INCONVENIENCE TO THE LOCAL RESIDENTS. EVERY ATTEMPT SHOULD BE MADE, WITHIN REASON, TO ALLOW RESIDENTS ACCESS TO THEIR DRIVEWAYS. HOWEVER, THE RESIDENTS WILL BE GIVEN WRITTEN NOTIFICATION A MINIMUM OF ONE WEEK IN ADVANCE OF THE WORK AND 48 HOURS IN ADVANCE OF THE WORK THAT THERE WILL BE CERTAIN TIMES WHEN ACCESS TO THEIR DRIVEWAYS WILL NOT BE AVAILABLE.

J.U.L.I.E. 1-800-892-0123
 NOTE: VISIBLE UTILITY STRUCTURES WERE LOCATED BY FIELD SURVEY AS SHOWN. UNDERGROUND UTILITY LOCATIONS WERE OBTAINED FROM AVAILABLE RECORD DRAWINGS AND ARE APPROXIMATE AND MAY NOT BE COMPLETE. CONTACT J.U.L.I.E. BEFORE EXCAVATING.

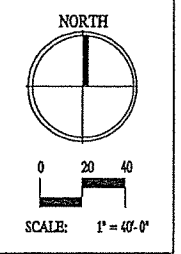

PUBLIC WORKS DEPARTMENT
 Engineering
 3505 N. Dimes Ln.
 Peoria, IL 61604
 PH 309-494-8800
 FAX 309-494-8855
 www.peoriago.gov

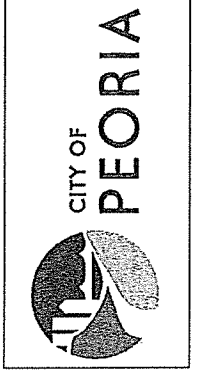

REVISIONS			
NO.	DATE	BY	DESCRIPTION
Δ			

AUSTIN ENGINEERING, CO., INC.
 Civil Engineering/Surveyors
 311 SW Water St., Suite 215
 Peoria, Illinois 61602
 License No. 184-001143

DATE:	06.17.16
DESIGN:	
DRAWN BY:	SDR
APPRD:	DLB
CLIENT:	COP
SHEET TITLE	IMPROVEMENT
SHEET NO.	C-3
JOB NO.	20-16-003

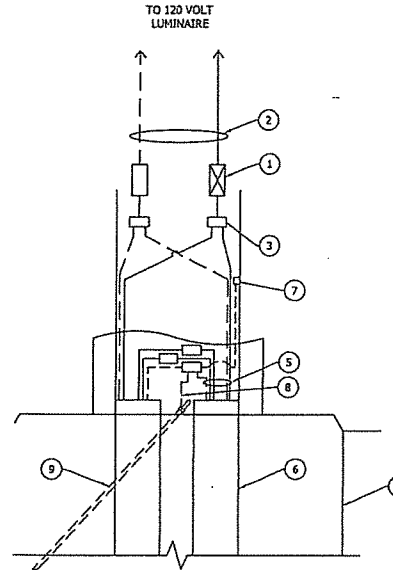

- 1 CONNECTOR KIT METHOD WITH A 7.5A FUSE FOR LUMINAIRE & 5A FUSE FOR RECEPTACLE (NEUTRAL SHALL BE NON-FUSED). FUSES SHALL BE TIME-DELAY TYPE FUSES INSIDE A FUSE HOLDER AND INSULATING BOOTS (BUSSMAN HEB SERIES OR APPROVED EQUAL).
- 2 NO. 10 A.W.G. WIRE
- 3 MULTIPLE COMPRESSION FITTINGS (SPLICE)
- 4 CONCRETE FOUNDATION
- 5 WIRE AS SHOWN ON PLANS
- 6 PVC RACEWAY
- 7 POLE GROUND LUG
- 8 #8 SOLID GROUND WIRE MECHANICALLY CLAMPED TO GROUND ROD
- 9 5/8" DIA. x 10' GROUND ROD

— PHASE CONDUCTOR
 - - - GROUND CONDUCTOR
 - - - NEUTRAL CONDUCTOR

4 LIGHT POLE HANDHOLE WIRING DIAGRAM
 N.T.S.

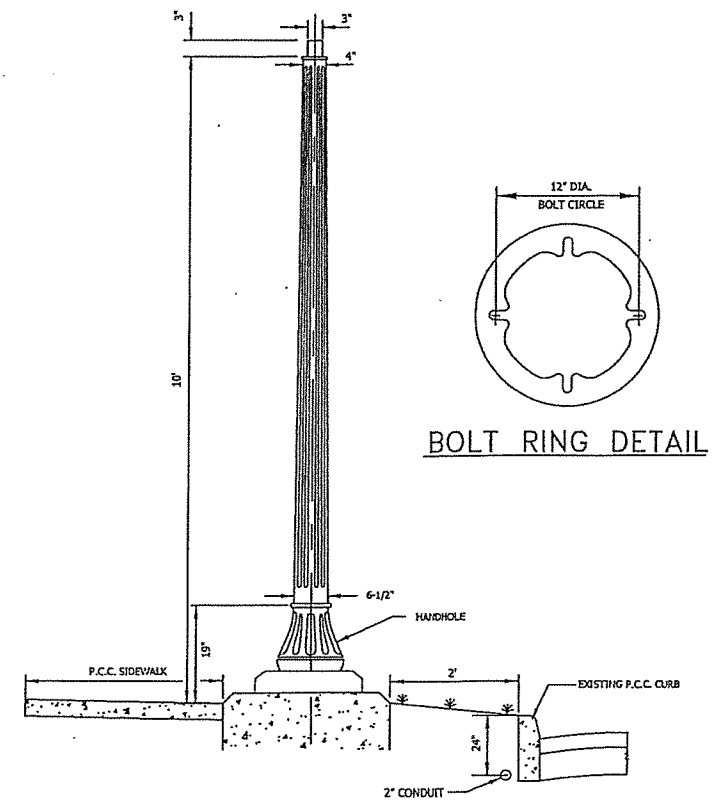

2 BOLT RING DETAIL

2 STANDARD LIGHTING POLE
 CITY OF PEORIA STANDARD ALUMINUM LIGHTING POLE (10')

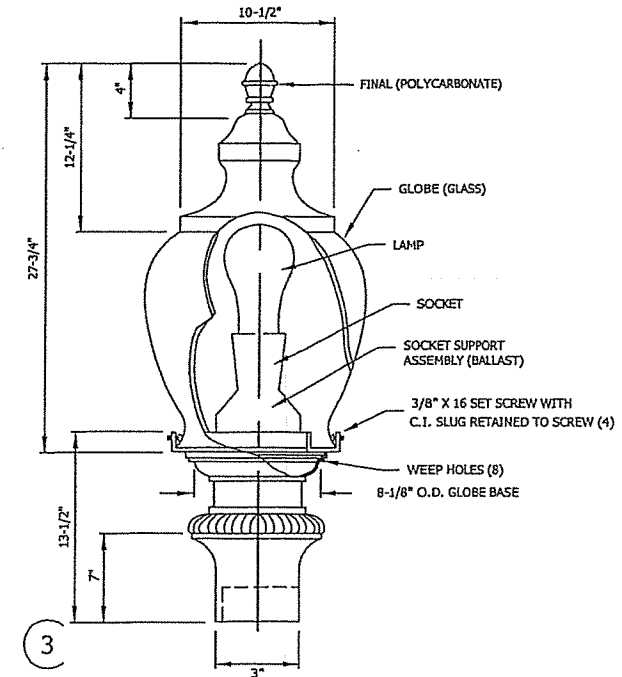

3 STANDARD ACORN LIGHTING FIXTURE
 C.O.P. STD. L.F. TY. 1

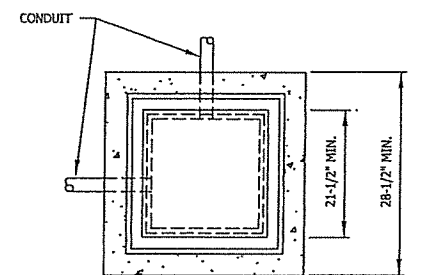

NOTE: MINIMUM WEIGHT OF FRAME & COVER TO BE 140 LBS.

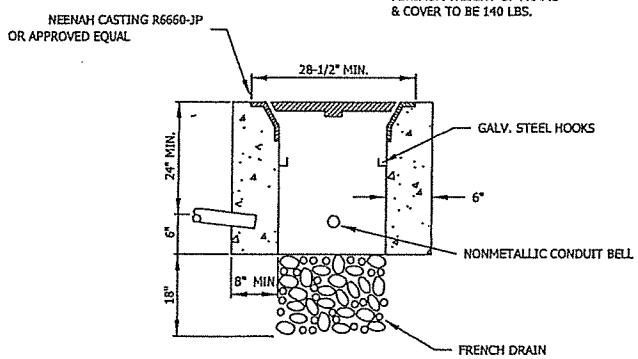

4 CONCRETE HANDHOLE

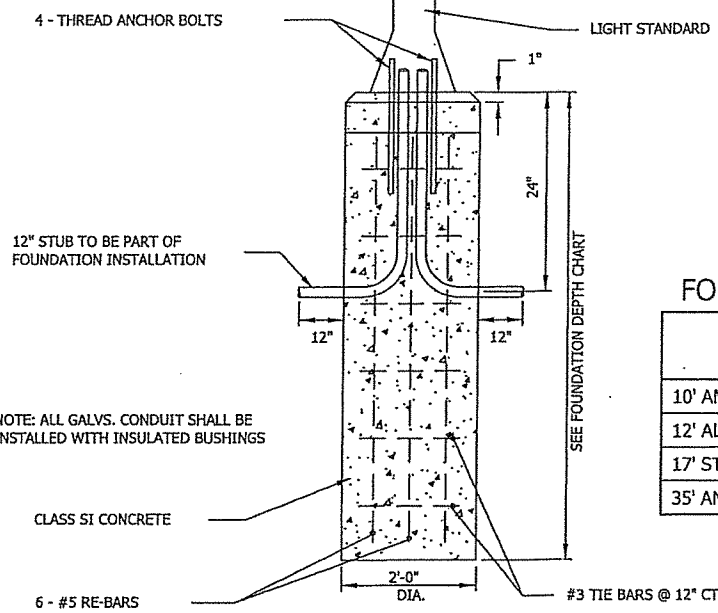
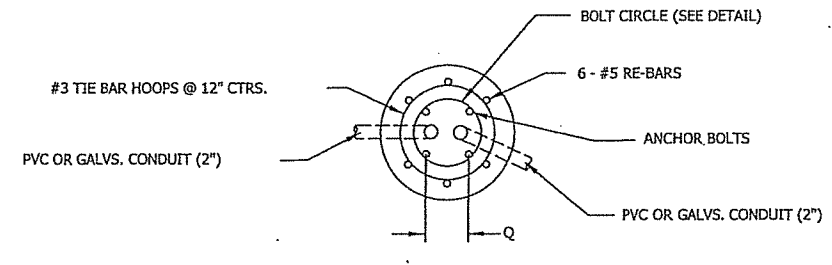

NOTE: ALL GALVS. CONDUIT SHALL BE INSTALLED WITH INSULATED BUSHINGS

5 CITY STANDARD STREET LIGHT FOUNDATION

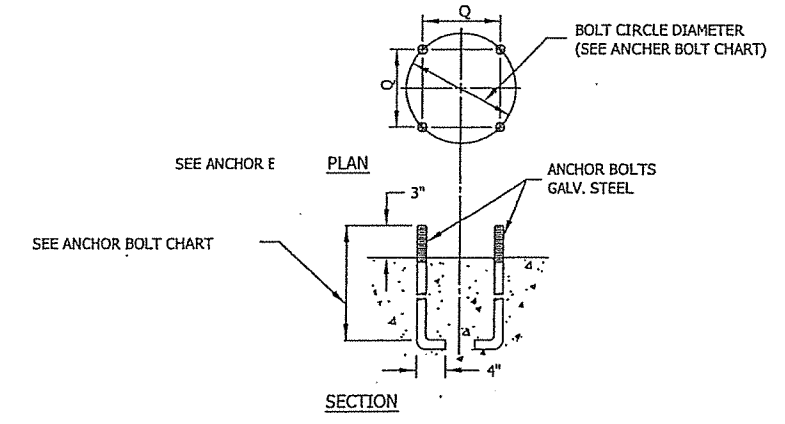

6 ANCHOR BOLT DETAIL
 NO SCALE

FOUNDATION DEPTH CHART

POLE TYPE	FOUNDATION DEPTH (FEET)
10' AND 12' ALUMINUM	3
12' ALUMINUM (THREE GLOBE)	4
17' STEEL	5
35' AND 45' DAVIT	7

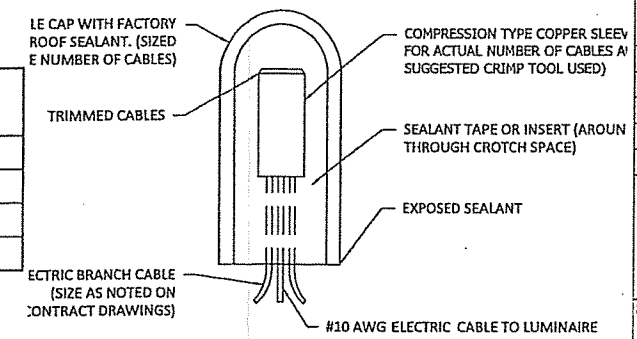

WATERPROOF SPLICE DETAIL
 N T S

PUBLIC WORKS DEPARTMENT
 Engineering
 3505 N. Dixie, Lt.
 Peoria, IL 61604
 PH 309-494-8800
 FAX 309-494-8855
 www.peoria.gov

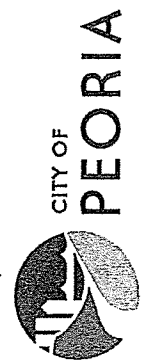

REVISIONS			
NO.	DATE	BY	DESCRIPTION

AUSTIN ENGINEERING, CO., INC.
 Consulting Engineers / Surveyors
 311 SW Water St., Suite 215
 Peoria, Illinois 61602
 License No. 164-001143

DATE: 06.17.16
 DESIGN:
 DRAWN BY: SDR
 APPRD: DLB
 CLIENT: COP

SHEET TITLE
DETAILS

SHEET NO.
C-4

JOB NO.
 20-16-003