

**CITY OF PEORIA
CONTRACT
24-22**

This agreement, made and entered into this 26th day of July A.D., 2022 by and between the City of Peoria, a municipal corporation, party of the first part and Industrial Video & Control - 330 Nevada St. Newton, MA 02460, his/their executors, administrators, successors or assigns, party of the second part.

WITNESSETH: That for and in consideration of the payments and agreements mentioned in the proposal hereto attached, to be made and performed by the party of the first part, and according to the terms expressed in the bond referring to these presents, the party of the second part agrees with said party of the first part, at his/their own proper costs and expense to furnish and deliver all the work, materials and supplies in accordance with the specifications contained in said proposal, and in full compliance with all of the terms of this agreement.

IT IS UNDERSTOOD AND AGREED that the, proposal, and statement of work and specifications are component parts of this contract and shall be deemed a part hereof. It is also understood and agreed that the contractor shall not assign, transfer, convey or otherwise dispose of this contract, or his right to execute it, or his right, title or interest in or to it or any part thereof, unless the previous written consent of the City Manager of the City of Peoria shall first be obtained thereto.

IN WITNESS WHEREOF, the said parties have executed these presents on the date above mentioned.

In accordance with the attached specifications, proposal and pricing sheet, Industrial Video & Control will provide 4 camera trailers and training for the Peoria Police Department.

The Contract term will begin July 26, 2022 and will end December 31, 2022.

THE CITY OF PEORIA

By 
City Manager

INDUSTRIAL VIDEO & CONTROL

By Jennifer Williams Digitally signed by Jennifer Williams
Date: 2022.07.27 10:50:41 -04'00'
(Member of firm or officer of corporation)

APPROVED FINANCE DEPARTMENT

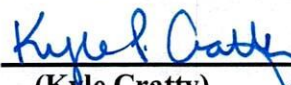
By 
(Kyle Cratty)

APPROVED LEGAL DEPARTMENT

By 
(Chrissie Kapustka)

APPROVED USING DEPARTMENT

By 
(Eric Echevarria)

ATTEST CITY CLERK

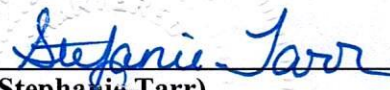
By 
(Stephanie Tarr)

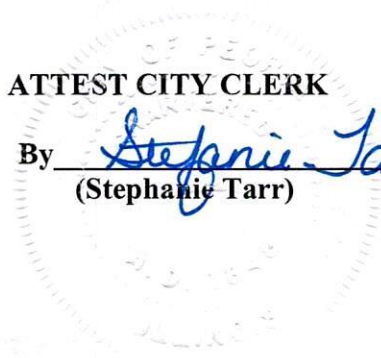

Industrial Video & Control Bid Proposal

**Prepared for
City of Peoria**

RFP #: 24-22 | RFP Title: Peoria Police Camera Trailer

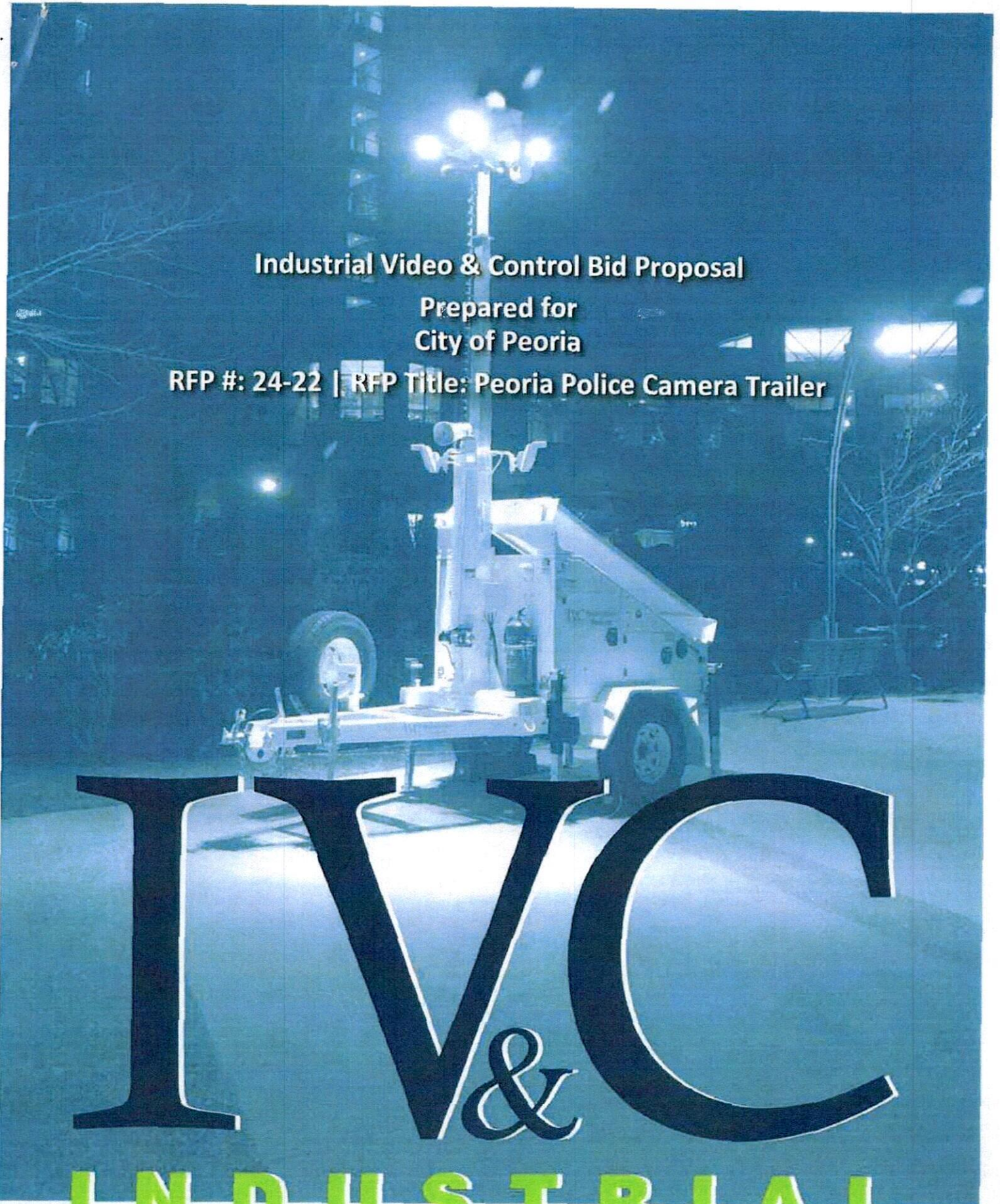

I V & C

**INDUSTRIAL
VIDEO & CONTROL**

IV&C **MobileVision**
INDUSTRIAL VIDEO & CONTROL **Products**

June 1, 2022

Jennifer Williams, Director of Sales
Industrial Video & Control
105 McDougall Court
Greenville, SC 29607

City Hall – City Purchasing Manager
Room 108, City Hall
419 Fulton St.
Peoria, IL 61602

Dear Purchasing Manager,

On behalf of Industrial Video & Control, I am excited to offer the attached bid proposal in response to the City of Peoria's Police Camera Trailer RFP. Industrial Video & Control is confident in its ability to design and manufacture the most efficient and effective mobile surveillance solution to meet or exceed the requirements outlined in the specifications. IV&C's ability to provide the best solution comes from over 20 years of experience in manufacturing customized and comprehensive video solutions for surveillance and monitoring of remote sites, industrial facilities, military installations, and municipal sites.

The following documents are enclosed with IV&C's bid proposal for your review:

- 24-22 Peoria Police Camera Trailer Request for Proposal Document
- Employer Report Form (CC-1)
- IV&C Equipment Proposal and Specifications
- IV&C Compliance Matrix
- Warranty Information
- Training Information

Thank you for allowing Industrial Video & Control to participate in this opportunity and present its proposed solution for meeting your surveillance requirements. I look forward to hearing from you upon completion of the evaluation stage. Should you have any questions or require any additional information regarding IV&C's proposal, I will be your primary point of contact and welcome you to reach out at any time.

Sincerely,

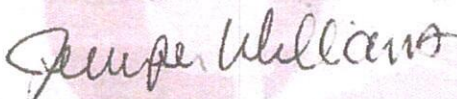

Jennifer Williams
Director of Sales

p: (617) 467-3059 x147 | m: (864) 706-5313
e: jwilliams@ivcco.com | w: www.ivcco.com

**Request for Proposal
Peoria Police Camera Trailer
#24-22**

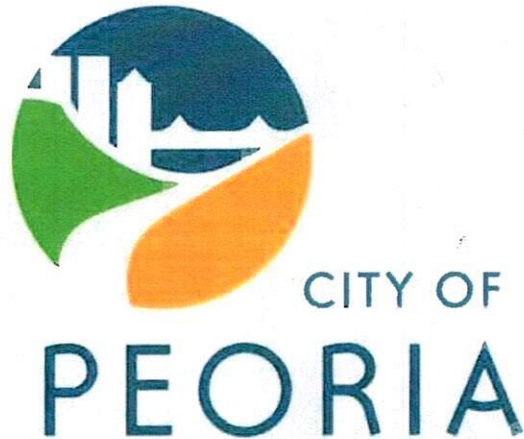

**ISSUED BY
DIVISION OF PURCHASING
CITY OF
PEORIA, ILLINOIS**

**Sealed Requests for Bids will be received at the office of
The PURCHASING MANAGER
Room 108, City Hall,
419 Fulton Street, Peoria, Illinois until 2:00 P.M.**

**Thursday June 2, 2022
for furnishing the materials, or services
described herein.**

**PLEASE RETURN ENTIRE
DOCUMENT AS YOUR RESPONSE. SUBMITTED BY: Industrial Video & Control**

INSTRUCTIONS TO PROPOSERS

1.1 **ACCEPTANCE OF PROPOSALS** The right is reserved, as the interest of the City may require, to reject any or all bids and to waive any non-material informality or irregularity in the bids received. All bids will be in English. The City will award the RFP as described below or reject all proposals within sixty (60) calendar days from the RFP opening date.

1.2 **ADDITIONAL COPIES OF SPECIFICATIONS** - Proposers may secure additional copies of the RFP specifications from the City of Peoria's Purchasing office, City Hall, 419 Fulton Street.

1.3 **RFP ENVELOPE IDENTIFICATION** - Proposers shall submit their response in a sealed envelope (sealed RFP) which shall be clearly labeled with the organization/individual name and address. Proposers should also indicate "**RFP# 24-22 PEORIA POLICE CAMERA TRAILER**" in the LOWER LEFT HAND CORNER OF THEIR ENVELOPE.

1.4 **MAILING OF BIDS** – One (1) original and four (4) copies of all responses are to be mailed or delivered to:

City Hall – City Purchasing Manager
419 Fulton St.
Peoria, IL 61602

1.5 **CLOSING TIME** - The RFP closing time will be based upon Central Standard Time or Central Daylight Time, whichever is in effect on the date the RFP is due.

1.6 **WITHDRAWAL OF BIDS** - Proposers may withdraw their proposals at any time prior to the RFP closing time by telephone, fax or written request. A telephone request must be confirmed in writing within 24 hours of the call and prior to closing time. No proposer shall withdraw his proposal for a period of sixty (60) calendar days from the RFP opening date. Negligence on the part of the proposer in preparing a proposal confers no right of withdrawal or modification of a proposal after it has been opened. No proposal will be opened which has been received after the closing time specified in the proposal and it will be returned unopened to the proposer.

1.7 **ALTERNATE PROPOSALS** - The specifications describe the supplies and/or service, which the City feels are necessary to meet the performance requirements of the City. Proposers desiring to submit a proposal on items which deviate from these specifications, but which they believe to be equivalent, are requested to submit alternate proposals. However, ALTERNATE TENDERS MUST BE CLEARLY INDICATED AS SUCH AND DEVIATIONS FROM THE APPLICABLE SPECIFICATIONS PLAINLY NOTED. The proposal must be accompanied by complete specifications of the items offered.

1.8 **AWARD** - An award will be made to the lowest qualified (responsive and responsible) proposal that complies with the terms and conditions of the specifications provided that it is in the best interest of the City to accept the proposal. Awards will be made on per item basis unless otherwise stated. The quality of the articles to be supplied, their conformity with specifications, their suitability to the requirements of the City and the delivery terms will be taken into consideration in making the award.

1.9 **PRICES** - Unit prices shall be shown for each unit on which there is a RFP and shall include all packing, crating, freight and shipping charges and cost of unloading supplies at destination

unless otherwise stated in the proposal. All prices shall be stated in U.S. dollars. Unit prices shall not include any local, state or federal taxes. In case of mistake in extension of price, unit price shall govern. All prices must be typewritten or written in ink. No erasures are permitted. Mistakes must be crossed out and corrections typewritten or written in ink adjacent thereto and initialed in ink by the party signing the proposal or his authorized representative.

1.10 SIGNATURES - Each proposal must be signed by the bidder with his usual signature. Bids by partnerships must be signed with the partnership name by one of the members of the partnership, or by an authorized representative, followed by the signature and title of the person signing. Proposals by corporations must be signed with the name of the corporation, followed by the signature and title of person authorized to bind it on the matter. All signatures must be in ink.

By signing and submitting the response to this document, the Vendor/Contractor/Consultant is certifying they have not been barred from bidding by Federal, State or Local governments and have not been suspended or debarred from receiving federal funding.

1.11 INVESTIGATION - Bidders shall make all investigations necessary to thoroughly inform themselves regarding the supplies and/or service to be furnished in accordance with the proposal. No plea of ignorance by the bidder, of conditions that exist or that may hereafter exist as a result of failure or omission on the part of the bidder to make the necessary examinations and investigations, will be accepted as a basis for varying the requirements of the City or the compensation to the bidder.

1.12 SAMPLES - Samples of items, when required, must be submitted within the time specified and at no expense to the City; and if not destroyed in testing, they will be returned at the proposer's request and expense. Samples, which are not requested for return within thirty (30) days, will become the property of the City.

1.13 RESPONSES—A response is requested of all proposers even if it is a "no bid." Do not include any personal information such as social security numbers that the bidder/proposer wishes to keep confidential.

1.14 RFP PROCESS—This process does not obligate the City to award a contract, or pay any cost incurred by the Vendor/Contractor/Consultant responding to this request. The City reserves the right to accept or reject any or all statements received because of this request. All information submitted in response to this request will become the property of the City.

Please be aware that it is the City's policy to not compensate a Proposer for any time or expenses incurred during the selection and negotiation processes.

1.15 EQUAL EMPLOYMENT OPPORTUNITY (EEO) – To be awarded a contract all Suppliers, Vendors and Contractors to the City of Peoria **must** be registered in the City of Peoria's Contract Compliance Program and have a current EEO Certification number. This program is unrelated to any State and Federal program.

The number is secured by completing and submitting, under notary seal, an Employer Report Form CC-1 (with required sexual harassment policy attached) to the City's Equal Opportunity Office. *Please note the Certificate of Compliance is valid for one (1) year and must be renewed annually.* The form may be d from the City's website (<http://www.peoriagov.org/equal->

opportunity-forms). Click on Department Focus, Equal Opportunity Office, Forms, then select "Employer Report Form CC-1" or "Renewal." The forms can also be obtained by writing or calling: The forms can also be obtained by writing or calling:

**City of Peoria
Equal Opportunity Office
419 Fulton Street
Peoria, IL 61602
(309) 494-8530 Voice
(309) 494-8532 TTY**

In accordance with Chapter 17 of the Peoria Municipal Code, a fifty-dollar (**\$50.00**) processing fee will be charged with each original submission of the Employer Report Form CC-1 that results in an approved certificate as well as the Annual Renewal Application. The only exception to payment of the processing fee is neighborhood associations.

Although all vendors are encouraged to obtain Equal Employment Opportunity Certification, vendors do not need an Equal Opportunity Certification to respond to an RFP proposal. The EEO Certification Number is only required prior to the award of the contract.

EEO CERTIFICATION* (Check one):

I/We are presently applying for the EEO Certification. Employer Report Form (CC-1) is completed and enclosed.

Presently, I/we have the Employer Report Form (CC-1) on file with the City of Peoria, Office of Equal Opportunity and have a current Certificate of Compliance Number.

Certificate of Compliance Number: _____

*Please note there is a \$50.00 processing fee for both new and renewal certification requests.

1.16 GOOD FAITH EFFORTS REQUIREMENTS (projects exceeding \$50,000)

Minority/Women Business Enterprise (M/WBE) Utilization – Proposers must demonstrate that they made good faith efforts to meet participation goals. Documentation supportive of their good faith efforts to utilize M/WBEs must be submitted at the time of bid. For details on what records, see M/WBE Participation Requirements for Good-Faith Efforts, Section III.

Compliance Reporting Minority/Female Worker Utilization - The General Contractor and its subcontractors must provide to the City of Peoria documentation on their good faith efforts to comply with the workforce participation goals. This would include, but not limited to, weekly certified payroll reports. All information will be provided through **ePrismSoft**, an electronic web-based compliance tracking software. Access to **ePrismSoft** has been furnished by the City of Peoria. To activate access the General Contractor and subcontractors must register at www.eprismsoft.com. Use the help page, which is accessible before logging in, to get started. If needed, contact the Contract Supervisor for help.

CONTRACT TERMS

2.0 TAXES - The City is exempt, by law, from paying State and City Retailers Occupation Tax, State Service Occupation Tax, State Use Tax and Federal Excise Tax. The City will execute tax exemption certificates whenever required. The unit prices should be exclusive of all taxes. In the event the unit price includes taxes, the bidder must show the amount of tax included in the unit price.

2.1 CITY'S AGENT - The City Purchasing Manager or his designee shall represent and act for the City in all matters pertaining to the RFP and contracts in conjunction thereto.

2.2 PATENTS - The successful bidder agrees to protect, defend and save the City harmless against any demand for payment for the use of any patented material process, article or device that may enter into the manufacturer, construction or form a part of the work covered by the contract.

2.3 HUMAN RIGHTS ACT - The contract will be subject to and governed by the rules and regulations of the Illinois Human Rights Act 775ILCS5/1-101 et seq. and as amended. And the provision of Chapter 775 of the Illinois Compiled Statutes 5/2-105 on Sexual Harassment policies.

2.4 NON-COLLUSION - With the executing of this RFP the Bidder is certifying to non-collusion in the preparation and submittal. The RFP must be properly executed by the proposer or the RFP will not be considered for acceptance.

2.5 DEFAULT - In case of default by the contractor, the City will procure the articles services from other sources and hold the contractor responsible for any excess cost incurred.

2.6 CANCELLATION - The City reserves the right to cancel the whole or any part of the contract, if the contractor fails to perform any of the provisions in the contract or fails to make delivery within the time stated. The cancellation notice will be written and delivered by certified mail to contractors address on record. In the event the contract is canceled, the vendor may be declared an irresponsible vendor by the City Manager and as a result may be disqualified from doing business with the City for the period of one year in accordance with Section 10-102 of the Peoria City Code. The contractor will not be liable to perform if situations arise by reason of strikes, acts of God or the public enemy, acts of the City, fires or floods.

2.7 PRICES SPECIFIED - The successful bidder agrees to furnish the material or services according to the City's plans, specifications, and conditions and at prices specified hereon.

2.8 BID-RIGGING OR BID-ROTATING - By the signing of this bid, the Bidder is certifying that the company is not barred from bidding on this RFP as a result of a conviction for the violation of State of Illinois laws prohibiting bid-rigging or bid-rotating per Public Act 720ILCS, Section 5-33E-3 and 5/33E-4.

2.9 DELINQUENT PAYMENT - By the signing of this bid, the Bidder is certifying that the company is not delinquent in the payment of any indebtedness, tax, fee, liens, fines owed or accruing to the City of Peoria or in the payment of any tax administered by the Illinois Department of Revenue and is in compliance with the terms and conditions of Section 10-109 of the Peoria City Code; and Chapter 65 of the Illinois Compiled Statutes, Section 5/11-42.1-1.

2.10 INSURANCE – The successful Proposer shall obtain, at its own expense, all necessary insurance about its fiduciary responsibility to the City of Peoria. Said Proposer shall indemnify and hold harmless the City of Peoria, its officials, officers, directors, employees, heirs and assigns from all actions, claims, demands or suits at law or equity for damages, costs, loss, or other injury as a result of the contract.

The City does not assume any liability for acts or omissions of contractor and such liability rests solely with contractor.

Contractor's Insurance – The contractor and all subcontractors shall secure and maintain such insurance policies as will protect the contractor or subcontractors from claims for bodily injuries, death or property damage which may arise from operations under this Contract whether such operations be by contractor or anyone employed by contractor directly or indirectly. The following insurance policies are **required**:

- Statutory Worker's Compensation
 - Comprehensive General Liability

Combined Single Limit	\$1,000,000.00
Property Damage	\$1,000,000.00
 - Automobile Public Liability and Property Damage

Combined Single Limit	\$1,000,000.00
Property Damage	\$1,000,000.00
- **Insurance Inclusions** – The comprehensive general liability insurance shall include independent contractors' protective liability, products and completed operations broad form property damage coverage. The completed operations and products liability shall be maintained for two years after final payment.
 - **Contractual Liability** – The insurance required above shall include contractual liability insurance coverage for the contractor's obligations under the section below entitled, "Hold Harmless and Indemnification Agreement".
 - **Certificates of Insurance** – Certificates of insurance acceptable to the City indicating insurance required by the Contract is in force shall be filed with the City prior to contract approval by the City. These certificates shall contain a provision that coverage afforded under the policies will not be canceled until at least thirty (30) days prior written notice has been given to the City.

2.11 PRECEDENCE - Where special conditions are written in the specifications, these conditions shall take precedence over any conditions listed under the "Instructions to Proposers."

2.12 GOVERNING – This contract will be governed by the laws of the State of Illinois. The Contractor/Vendor agrees that Chapter 10 of the Code of the City of Peoria is hereby incorporated by reference, as if set out verbatim.”

2.13 AFFIRMATIVE ACTION REQUIREMENTS - “The Contractor/Vendor will not discriminate against any employee or applicant for employment because of race, color, religion, sex, sexual harassment, ancestry, national origin, place of birth, age or physical or mental handicap(s) which would not interfere with the efficient performance of the job in question. The Contractor/Vendor will take affirmative action to comply with the provision of this division and will require any Subcontractor to submit to the City written commitment to comply with this division. The Contractor/Vendor will distribute copies of this commitment to all persons who participate in recruitment, screening, referral and selection of job applicants, prospective job applicants, member or prospective Subcontractors.”

“The Contractor/Vendor agrees that the provision of Division 4 of Article III of Chapter 17 of the Code of the City of Peoria is hereby incorporated by reference, as if set out verbatim.”

2.14 EMPLOYEE EMPLOYMENT RESTRICTIONS - The Contractor agrees, as a condition of accepting this contract with the City of Peoria, that, for a period of one (1) year following completion of this contract, it shall be prohibited from hiring, directly or indirectly, any City employee or official who was involved, directly or indirectly in: (1) the selection and/or recommendation to select the Contractor for performance of this contract; (2) coordinating the efforts of the Contractor in the consummation or completion of this contract; or (3) monitoring or determining the performance of the Contractor. The Contractor further acknowledges and agrees that, upon the City’s determination that a violation of this provision has occurred, the penalty imposed, at the sole discretion of the City, may include one or more of the following: (1) cancellation of any other contract(s) between the City of Peoria and the Contractor; (2) disqualification of the Contractor from bidding or being awarded future contracts with the City of Peoria for a period of two (2) years; and/or (3) payment of liquidated damages to the City of Peoria in the amount of Twenty-Five Thousand Dollars (**\$25,000.00**).

This does not apply to any City Employee involved in the 2011-12 reduction in force; nor does it apply to parties taking the Early Retirement Incentive offered by the City from November 1, 2011 through November 1, 2012.

3.0 LOCAL PURCHASING

For purchases of \$10,000.00 or greater, if:

- (1) the lowest bidding local vendor is a responsible bidder; and
- (2) the lower-bidding responsible proposers are not local vendors; and
- (3) the lowest bidding local vendor’s RFP is higher than the non-local vendor by no more than three (3) percent, then that local vendor should be considered the lowest responsible bidder. In case of a dispute regarding the application of this provision, the decision of the City Manager or the Purchasing Agent acting for him/her shall be final. For purposes of this subsection, a local vendor shall be one that sells goods or services to the public, either retail or wholesale, and owns or leases

a physical, commercial business location, with on-site staffing and regular business hours, within the corporate limits of the City of Peoria, Illinois. The provisions of this subsection shall not be applied to a contract if the funding source prohibits local preference by law, rule or regulation.

4.0 REFERENCE - All the contract terms shall be incorporated by reference into any written contract.

CRITICAL DATES:

Selection will be made per the following Schedule:

RFP Advertised May 3, 2022

Due Date for Proposals at 2:00 p.m. June 2, 2022

PAGE INTENTIONALLY LEFT BLANK

INFORMATION FOR BIDDERS

PURPOSE AND INTENT

The purpose of this RFP is to solicit bid proposals to engage a vendor to provide two portable off-grid (solar or generator) powered surveillance units to the City of Peoria Police Department. The intent of this RFP is to award a contract to that responsible bidder whose bid proposal, conforming to this RFP is most advantageous to the City, price and other factors considered.

BACKGROUND

The City is seeking proposals to furnish the Police Department with two portable, towable, self-powered surveillance camera stations or trailers.

Proposals shall include equipment, delivery, service costs associated, documentation, training of station personnel, and accessories as described in Specifications.

KEY EVENTS

ELECTRONIC QUESTION AND ANSWER PERIOD

The City will accept questions and inquiries from all potential proposers electronically until **5:00 P.M. Wednesday - May 25, 2022**. Submit all questions through the Illinois Purchasing Group (BidNet) platform.

Questions should be directly tied to the RFP and asked in consecutive order, from beginning to end, following the organization of the RFP. Each question should begin by referencing the RFP page number to which it relates.

Proposers are not to contact the Peoria Police Department directly, in person, by telephone or by email, concerning this RFP.

In order to be considered for award, the proposal must be received by the City of Peoria on or before:

Thursday June 2, 2022 @ 2:00 PM.

LOCATION IS AS FOLLOWS:

CITY OF PEORIA
PURCHASING DIVISION
419 FULTON ROOM 108
PEORIA, ILLINOIS 61602

ADDITIONAL INFORMATION

ADDENDA: REVISIONS TO THIS RFP

In the event that it becomes necessary to clarify or revise this RFP, such clarification or revision will be by addendum. Any addendum to this RFP will become part of this RFP and part of any contract awarded as a result of this RFP.

All RFP addenda will be posted on the City of Peoria website.

<http://www.peoriagov.org/finance-department/purchasing-division/>

There are no designated dates for release of addenda.

It is the sole responsibility of the bidder to be knowledgeable of all addenda related to this procurement. Addenda should be acknowledged and included with submission packet.

SPECIFICATIONS:

GENERAL

The equipment and services to be acquired are for the purchase, warranty, maintenance, repair, training and delivery of two (2) self-powered portable surveillance units.

- Must be on a vehicle-towed or otherwise portable platform.
- Surveillance, networking, and all other electronic equipment must be self-powered (not reliant on grid power), by means of solar, generator or other means.
- Surveillance Equipment must include:
 - o Onboard DVR/NVR or Video Management Platform:
 - Capable of motion or other event activated recording
 - Minimum 1 TB storage
 - Networking Interface (NIC/LAN Port)
 - On-site User Accessible
 - o Password/Encryption Protection
 - o Remote Accessibility
 - o Capability to be integrated with client on-site Exacq-Vision Client (client supplied licensing)
 - o Minimum 1 IP Camera per the below specifications
- Camera included with the unit must be capable of:
 - o High resolution video (1080p or higher)
 - o Night/infrared video capture
 - o Motion or other event activated recording
 - o Capable of 360 degree viewing (i.e., 4 cameras/sensors) or Pan-Tilt-Zoom (PTZ)
- Networking equipment must be able to accommodate all cameras/surveillance equipment and cellular connection
- Cellular connection must support SIM cards from Verizon, AT&T and T-Mobile
- SIM Card/Cellular Plan can be client supplied or vendor supplied (if vendor supplied response will include associated costs)

- Solar power system must be capable of 24 hours backup power in the event solar becomes inoperable/unable to provide charge.
- Generator power must be capable of powering the system for 24 hours on single fuel charge
- If both Solar and Generator power are included on the same platform, the generator must also provide charge to the solar batteries when needed to supplement the solar system

WARRANTY

Minimum 3 Year Warranty, Support Agreement, Maintenance Agreement, or other type of Warranty covering System Failure, Equipment Failure and Full Support of both Software and Hardware

- o Sample Contract, Master Service Agreement or Other Legally Binding Document

FULL OPERATIONAL STATUS

Full operational acceptance is when the equipment is delivered by the contractor, the equipment is in good working order and is made operational in accordance with standard specifications and the equipment is accepted by the Police Chief.

Full operational acceptance shall be determined by:

- Demonstration of the delivered system to the satisfaction of the City's Police Technology Administrator
- Two (2) hours training of personnel to operate the system effectively.
- Site personnel shall be provided with a graphic "step-by-step" instructional manual illustrating the recording, finalizing, and down-loading process.

TRAINING

Training support shall include all required system training to bring staff to a functional level of system operation. The contractor shall provide training and manuals for all equipment and system operation immediately following system installation.

Training for equipment and system operation shall be included in the price of the equipment. The contractor shall provide all training materials in hard and soft copy.

GENERAL REQUIREMENTS

CONTRACTOR PERSONNEL

All personnel must observe all regulations in effect at the Police Headquarters. While on City property, contractor staff are subject to control of the City, but under no circumstances are such persons be deemed to be employees of the City.

The contractor or its personnel must not represent themselves as employees of the City.

On all City of Peoria Police Department installations, the contractor shall provide the names of its employees conducting the installation to the Police Department for background checks. No installer with a criminal history will be permitted to work on the Peoria Police Department installations.

The Police Chief may request the contractor to transfer from the work crew employees who are found by the City to be incompetent, prone to excessive tardiness, absenteeism, theft or after violation of the facility contractor / safety rules.

The technical personnel that install the proposed system must be fully trained and qualified to install the proposed system.

ADDITIONS, SUBSTITUTIONS, DELETIONS

The contractor may substitute or add products during the term of the contract provided that they are the same brands as originally awarded and serve the same comparable functions as the product they replace. After the contract award, additions, substitutions and/or deletions may be allowed under the following condition:

- Written approval of the Peoria Police Technology Administrator.

PROPOSAL PREPARATION

Proposals should present information in a straightforward and concise manner, while ensuring complete and detailed descriptions of the Firm's/Team's abilities to meet the requirement of this RFP. Emphasis will be on completeness of content.

Please include a cover letter shall include the RFP Title and Number, Name, Title, Email Address, Phone Number and Addresses of the Proposing Team's main contact.

EVALUATION

Project Cost – 100 points
Project Approach – 50 points
Supplier Diversity (MBE/WBE) 25 points
Vendor Experience – 25 points

Total Maximum Points – 200 points

CITY OF PEORIA
PROPOSAL

The executing of this form certifies understanding and compliance with the total bid package.

PROPOSAL SUBMITTED BY:

Industrial Video & Control Co., LLC

Respondent

330 Nevada St.

Address

Newton

MA

02460

614-467-6059

City

State

Zip

Daytime Telephone #

Jennifer Williams

jwilliams@ivcco.com

Contact Person

Email Address

Jennifer Williams

Director of Sales

Name of Authorized Agent or Officer

Title

Jennifer Williams

Signature of Authorized Agent or Officer

5/31/22

Date

SECTION VI. WORKFORCE INFORMATION (FULL TIME ONLY)

SEE THE INSTRUCTIONS BEFORE COMPLETING THIS SECTION.

JOB CATEGORIES	OVERALL TOTALS		WHITE (Not of Hispanic Origin)		BLACK OR AFRICAN AMERICAN		HISPANIC OR LATINO		ASIAN OR PACIFIC ISLANDER		AMERICAN INDIAN OR ALASKAN NATIVE	
	M	F	M	F	M	F	M	F	M	F	M	F
Office & Managers	2	2	2	1						1		
Professionals	3	1	2						1	1		
Technicians	5	0	1				2		2			
Sales Workers	4	0	2				1		1			
Office & Clerical	0	1		1								
Craft Workers (Skilled)	3	0	2				1					
Operatives (Semi-Skilled)	2	0	2									
Laborers (Unskilled)	0	0										
Service Workers	0	0										
TOTAL	19	4	11	2			4		4	2		

M= MALE F=FEMALE

SECTION VII. GENERAL INFORMATION

1. DESCRIBE THE GOODS OR SERVICES PROVIDED BY THE EMPLOYER.	TRAILERS PROVIDING VIDEO MOBILE SURVEILLANCE	
2. IS IT THE COMPANY'S POLICY TO RECRUIT, HIRE, TRAIN, UPGRADE, PROMOTE, AND DISCIPLINE PERSONS WITHOUT REGARD TO RACE, COLOR, SEX, RELIGION, NATIONAL ORIGIN, VETERAN STATUS, AGE, MENTAL AND/OR PHYSICAL DISABILITY?	YES <input checked="" type="checkbox"/>	NO <input type="checkbox"/>
3. HAS THE COMPANY DEVELOPED A WRITTEN AFFIRMATIVE ACTION PLAN?	<input type="checkbox"/>	<input checked="" type="checkbox"/>
4. HAS THE COMPANY DEVELOPED A WRITTEN SEXUAL HARASSMENT POLICY STATEMENT? ATTACH A COPY IF THIS IS THE FIRST TIME APPLYING FOR AN EEO CERTIFICATION NUMBER.	<input type="checkbox"/>	<input checked="" type="checkbox"/>
5. HAS THE COMPANY NOTIFIED ITS ADVERTISING AND RECRUITMENT SOURCES THAT IT IS AN EQUAL OPPORTUNITY EMPLOYER?	<input checked="" type="checkbox"/>	<input type="checkbox"/>
6. HAS THE COMPANY BEEN CERTIFIED AS A MINORITY, WOMAN OR DISADVANTAGED BUSINESS ENTERPRISE BY A STATE OR FEDERAL AGENCY? CHECK STATUS ___ MBE ___ WBE ___ DBE ATTACH COPY IF NOT PREVIOUSLY SUBMITTED.	<input type="checkbox"/>	<input checked="" type="checkbox"/>
7. DOES THE CONTRACTOR UNDERSTAND AND AGREE THAT IT IS ILLEGAL TO MAINTAIN SEGREGATED FACILITIES FOR ANY OF ITS EMPLOYEES ON THE BASIS OF RACE, RELIGION, COLOR, NATIONAL?	<input checked="" type="checkbox"/>	<input type="checkbox"/>
8. HAS THE COMPANY EVER BEEN DISQUALIFIED FROM CONDUCTING BUSINESS WITH A LOCAL, STATE, OR FEDERAL AGENCY? IF SO, PLEASE PROVIDE DATES AND THE REASONS FOR DISQUALIFICATION	<input type="checkbox"/>	<input checked="" type="checkbox"/>

SECTION VIII. CERTIFICATION

I certify that the information provided in this report, and in any attachments thereto, is true and accurate to the best of my knowledge and belief. The employer filing this report agrees that all applicable ordinances and administrative policies, procedures regulating affirmative action and equal employment opportunity are hereby incorporated by the individual authorized to sign this form on behalf of the employer.

SIGNATURE 	PRINT NAME & TITLE NORMAN FAST - CEO	TELEPHONE NUMBER 617-467-3059	DATE 5/31/2022
---	---	----------------------------------	-------------------

Equipment **PROPOSAL**

Prepared for

City of Peoria

City Hall - City Purchasing Manager
Room 108, City Hall
419 Fulton St.
Peoria, IL 61602

Prepared by

Industrial Video & Control

Jennifer Williams

(617) 467-3059 ext 147

jwilliams@ivcco.com

Number AAAQ3193

Date Jun 1, 2022

**RFP #24-22 PEORIA POLICE
CAMERA TRAILER**

**MADE IN THE
USA**

IVC
&
**INDUSTRIAL
VIDEO & CONTROL**



INDUSTRIAL VIDEO & CONTROL

330 Nevada Street, Newton, MA 02460

t. 617.467.3059 f. 617.687.0751

"The Industrial Video Solutions Leader"

Qty	Description	Unit Price	Extended Price
2	Light Weight Surveillance Trailer	\$23,614.80	\$47,229.60

(1) [Light Weight Surveillance Trailer Base with NVR Enclosure](#)

Part#: MVT-3002-NVR

Solar powered trailer system with 25' telescoping mast, rugged light weight design, and a power system with a 400Ah battery pack and 760 watts of solar.

- 400Ah battery pack - 2 x 200Ah batteries
- 2 x 380 watt solar panels for 760 watts total with 13 position angle adjustment
- Includes high efficiency MPPT solar charge controller with LCD control panel for easy monitoring
- DOT approved lighting package includes marker lights with 7 way wire harness
- Anti-theft measures - locking compartments, wheel lock immobilizes trailer
- Waterproof mast box for mounting equipment internally and externally
- Includes additional enclosure for housing Network Video Recorder



(1) [Pelco Spectra® Pro IR Series IP PTZ Outdoor Camera](#)

Part#: P2230L-ESR

Pelco's Spectra® Pro IR Series can see in absolute darkness. The Infrared Illumination (IR) has proportional brightness based upon zoom, creating visible pictures without any light up to 150 m from the camera.

Spectra Pro IR Series provides a Full HD 1080p 30x optical zoom camera that runs at up to 60 frames per second and provides up to 120dB of True Wide Dynamic Range (WDR).



(1) [Cradlepoint IBR900 Ruggedized 3G/4G/LTE Router](#)

Part#: IBR-900

The Cradlepoint COR IBR900 Series router offers a ruggedized 3G/4G/LTE networking platform designed to provide connectivity across a wide range of mobile applications. With an embedded 600 Mbps modem for LTE Advanced, optional second modem, and Wave 2 dual-band, dual concurrent Gigabit WiFi, the IBR900 Series routers provide reliable 24x7 connectivity.

- Multi-carrier 4G LTE support with dual-SIM capability
- Supports Ethernet (T1, DSL, Cable, MetroE), WiFi as WAN, and Metro WiFi
- Dual-modem capability for failover or load balancing
- Ruggedized to ensure always-on connectivity
- Monitor uptime with real-time alerts



(1) [Rugged Onboard Network Video Recorder](#)

Part#: DURABOOK-DM-S14I

The laptop server for NVR software records to a local hard drive and allows for remote monitoring. Video Management Software is loaded onto the system for easy access to live or recorded video on a mobile device or PC.

- 8th Generation Intel® Core™ i5 Processor
- Windows 10 Pro 64 Operating System
- 8 GB DDR4 2666MHz
- 14.0" FHD WVA (1920 x 1080) anti-glare non-touch display
- MIL-STD 810G graded for extreme ruggedness and reliability



**INDUSTRIAL VIDEO & CONTROL**

330 Nevada Street, Newton, MA 02460

t. 617.467.3059 f. 617.687.0751

"The Industrial Video Solutions Leader"

Qty	Description	Unit Price	Extended Price
-----	-------------	------------	----------------

- 256 GB Solid State Drive for software + 2TB video storage

Options

Additional PTZ Camera - Spectra® Pro IR Series IP PTZ Outdoor Camera (Optional)
This option can be added for: \$2900.00 Each

Onsite Training & Initial Setup - 1 Day (Optional)
This option can be added for: \$2250.00 Each

SubTotal	\$47,229.60
Tax	\$0.00
Shipping	\$2,200.00
Total	\$49,429.60

IVC MobileVision Products

MVT-3002

Lightweight Surveillance Trailer

- 760 watt solar array
- Lightweight design, easily towed
- Operates in extreme environments
- Remotely monitored and controlled
- 24/7 unattended operation
- Edge recording / storage
- Optional alarm strobe light
- HD PTZ IR Cameras



► Lightweight Surveillance Trailer Specifications

Tower Dimensions	
Width	4'11"
Length	11' 10"
Height	10' 1"
Camera / Equipment Box	Mounted at top of mast, CAT 6 & 1.6mm/4 Electric Cables
Trailer Details	
Axle	A/T single axle
Mast Raise/Extension	24VDC Electric winch
Mast Height	25ft Mast
Anti-theft Measures	Locking Compartments & Wheel Locks
Solar System	
No. of Solar Panels	2 x 380W
Panel Wattage/Output	760W
Panel Material	Polycrystalline
Controller	Maximum Power Point Tracking (MPPT)
Battery	
No. of Batteries	2 x 200AH
Capacity	400AH
Voltage	DC 12V
Material	SLA Gel
Supplied Voltage	24V
PTZ Camera (1)	
Effective Pixels	1920 x1080 (HDTV 1080p)
Focal Length	32x optical zoom
Compression	M-JPEG, H.264, H.265
Minimum Illumination	Color: 0.06 Lux@F1.4 0 Lux at 250m with IR
Edge Storage	Micro SD, Max 2TB
Recording	Edge software records video data on SD Card
Network/Local Storage	
Local Storage	SD Card
Wireless Connectivity	4G LTE cellular w/WiFi, 2.4GHz or 5GHz radio
Wired Connectivity	1000Base-T (RJ-45)

► ordering information

MVT-3002

The base model described here can be customized to suit your application needs.



330 Nevada St., Newton, MA 02460 www.ivcco.com 617-467-3059

© 2018, Industrial Video & Control Co. The Industrial Video & Control Co. logo is a registered trademark of Industrial Video & Control Co.. All other company names and products are trademarks or registered trademarks of their respective companies. All information provided is subject to change without notice. 03/02/2020



Spectra® Pro IR Series IP PTZ Outdoor Camera

HIGH-SPEED PTZ, 30X MODELS, FULL HD, WDR, LOW-LIGHT PERFORMANCE

Product Features

- 850 nm IR Illumination to 150 m
- H.265, H.264, and MJPEG Video Encoding
- Tilt Range +15° to -90° Degrees
- Low Light Down to 0.1 lux
- IR Illumination with Proportional Brightness Based Upon Zoom
- Up to 120 dB True Wide Dynamic Range (WDR)
- Sabotage and Simple Motion Detection
- Pelco's Smart Compression Technology
- Up to Full HD 1080p
- Up to 60 Images per Second (ips)
- Power Over Ethernet (802.3bt), 24 VAC, 48 VDC
- Electronic Image Stabilizer (EIS)
- Up to 2 TB Edge Storage with micro SDHC/SDXC Card
- 3-Year Warranty and Support

IR Illumination with Lookup

Pelco's Spectra® Pro IR Series can see in absolute darkness. The infrared illumination (IR) has proportional brightness based upon zoom, creating visible pictures without any light up to 150 m from the camera.

The IR wavelength is 850 nm giving an almost undetectable light source in locations where visible light is undesired or light pollution is regulated.

The Pro IR Series offers a wider tilt range giving the camera the ability to look above the horizon 15 degrees (center of field of view).

Full High Definition Camera

Spectra Pro IR Series provides a Full HD 1080p 30x optical zoom camera that runs at up to 60 frames per second and provides up to 120dB of True Wide Dynamic Range (WDR). The new camera is available with 30x optical zoom.

Embedded Features

Included in all models are built in video analytics (e.g. Sabotage and Simple Motion Detection). Spectra Pro IR also allows for up to 16 configurable window blanks. White Balance modes including Auto or Manual are available for overcoming difficult lighting conditions day and night. Spectra Pro IR supports up to 2 TB of onboard local storage (not supplied) that is easily accessible through the ONVIF Profile G protocol or FTP.

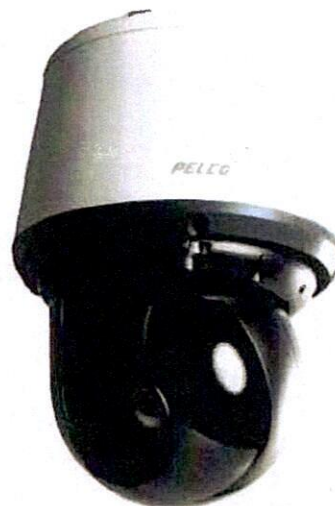

VideoXpert™



Video Encoding

Spectra Pro IR Series provides three methods of video encoding: H.265 Main profile, H.264 High/Main/Baseline profiles and MJPEG.

Intuitive Design

Spectra Pro IR Series features the same ease of installation and maintenance that you have come to expect from Spectra.

VMS Integration

Spectra Pro IR easily connects to Pelco IP and hybrid video systems such as VideoXpert, Endura 2.0 (or later), and Digital Sentry 7.3 (or later). The camera is also compatible with Digital Sentry NVS (DS NVS), a full-featured video management software, which is available as a free download at www.pelco.com. DS NVS includes four free Pelco IP licenses and allows for the management of video from up to 64 cameras.

Pelco endeavors to be the most open and integrated camera provider in the industry and as a part of that effort Spectra Pro IR is integrated with a long and ever-growing list of 3rd party software and Video Management Systems (VMS).

BACK BOX FEATURES



NOTE: VALUES IN PARENTHESES ARE INCHES; ALL OTHERS ARE CENTIMETERS.

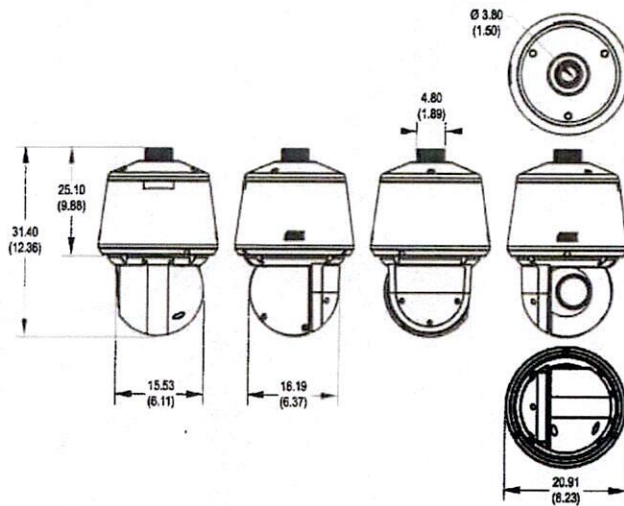

Environmental Pendant

- Environmental Pendant Available in Light Gray Finish, RAL7047
- Aluminum Construction
- IK10 Except for Glass (Glass IK7)
- Type 4X and IP66
- Uses 1 1/2-inch NPT Thread
- Includes Sun Shield, Heater, and Blower
- -40° to 60°C (-40°F to 140°F) Sustained Operating Temperature

CAMERA/OPTICS

Specification		Value
Sensor Type		1/2.8-inch CMOS Sensor
Optical Zoom		30X
Digital Zoom		12X
Maximum Resolution		1920 x 1080
Lens		f/1.6 ~ f/4.4, focal length 4.5 mm (wide) ~ 135 mm (tele)
Angle of View	Horizontal	59.8° (wide) ~ 2.34° (tele)
	Vertical	40.5° (wide) ~ 1.48° (tele)
	Diagonal	67.8° (wide) ~ 2.77° (tele)
Aspect Ratio		16:9
Light Sensitivity	Color (33 ms)	0.1 lux
	Color (125 ms)	0.025 lux
	Mono (33 ms)	0.05 lux
	Mono (125 ms)	0.01 lux
	Mono with IR	0.0 lux
		Note: Sensitivity in lux for 90% reflectance, f/1.6 (wide angle), 45 dB gain at 30 IRE (30% of signal level)
Day/Night Capabilities		Yes
Shutter Range		1/4 ~ 1/30,000 sec
Signal-to-Noise Ratio		>50 dB
IR Cut Filter		Yes
True Wide Dynamic Range		Up to 120 dB Max; 100 dB per IEC62676
Iris Control		Auto Iris with Manual Override
Backlight Compensation		Yes
Automatic Gain Control		Yes
Active Noise Filtering		3D Noise Filtering
Digital Image Stabilization (DIS)		Yes
Scanning		Progressive Scanning System

TECHNICAL SPECIFICATIONS

SOFTWARE FEATURES

- 256 presets
- 16 tours
- 4 patterns
- Field of View scan
- $\pm 0.1^\circ$ preset accuracy
- Multilingual menus (English, Spanish, Portuguese, Italian, German, French, Russian, Turkish, Arabic, Simplified Chinese, and Korean)
- Password protection
- 16 window blanks, configurable in size
- "Auto Flip" feature rotates camera 180° at bottom of tilt travel
- Configurable park with actions
- Proportional pan/tilt continually decreases pan/tilt speeds in proportion to depth of zoom

ANALYTICS BEHAVIORS

- **Camera Sabotage:** Detects contrast changes in the field of view. An alarm is triggered if the lens is obstructed by spray paint, a cloth, or a lens cap. Any unauthorized repositioning of the camera also triggers an alarm.
- **Motion:** Generates an alarm in a high traffic area when a person or object moves.

VIDEO

Video Encoding	H.264 High, Main, or H.265 Main, MJPEG
Video Streams	Up to 3 simultaneous streams; the second and third stream is variable based on the setup of the primary stream
Frame Rate	Up to 60, 50, 30, 25, 20, 16.67, 15, 12.5, 10, 7.5, 5, 3, 2, 1 (depending on the coding, resolution, and stream configuration)
Scan Type	Progressive
Available Resolutions	

Resolution				H.264 High Profile (IP GOP structure)	
MPx	Width	Height	Aspect Ratio	Maximum IPS	Recommended Bit Rate (Mbps)
2.07	1920	1080	16:9	60	10
2.07	1920	1080	16:9	30	7
0.92	1280	720	16:9	30	5.1
0.36	960	540	16:9	30	4.9
0.23	640	360	16:9	30	2.35
0.06	320	180	16:9	30	1.4

NETWORK

Supported Protocols	TCP/IP, UDP/IP (Unicast, Multicast IGMP), ARP, ICMP, UPnP, DNS, DHCP, RTP, RTSP, NTP, IPv4, IPv6, SNMP v2c/v3, QoS, HTTP, HTTPS, SSH, SSL, SMTP, FTP, and 802.1x (EAP)
Users	
Unicast	Up to 5 simultaneous users depending on resolution settings (2 guaranteed streams)
Multicast	Unlimited users H.264 or H.265
Security Access	Password protected
Secure Transmission	Transport Layer Security (TLS 1.2)
Software Interface	Web browser view and setup
Pelco System Integration	VideoXpert, Endura 2.0 (or later), Digital Sentry 7.3 (or later)
Open API	Pelco API or ONVIF Profile G, Profile S, Profile Q, and Profile T
Mobile Application	Integrated to Pelco Mobile App
Video Analytics	Simple motion detection and camera sabotage
Local Storage	Micro SDHC/SDXC slot (card not included), up to 2 TB; Capture 1–5–10 second video clips on camera sabotage, motion detection, or alarm input; record video continuously in the case of network outage with option to overwrite; access video through FTP protocol and ONVIF Profile G

MINIMUM SYSTEM REQUIREMENTS

Web Browser	Google Chrome 61.0 (or later), Internet Explorer® 8.0 (or later) or Firefox 3.5 (or later)
-------------	--

ANALYTICS

Required Systems for Pelco Analytics	
Pelco Interface	VideoXpert and Digital Sentry, WS5200 Advanced System Management Software on an Endura 2.0 (or later) system
Open API	The Pelco API can transmit behavior alarm data to third-party applications, available at pdn.pelco.com

PELCO'S SMART COMPRESSION TECHNOLOGY

Pelco's Smart Compression Technology lowers bandwidth and storage requirements by up to 70%. Our technology allows the user to make intelligent decisions regarding storage savings and image quality.

Pelco's Smart Compression Technology dynamically analyzes motion occurring within live video in real-time, to intelligently compress the information you don't need, while retaining details with clear quality in the areas that are important in the scene. By enabling Dynamic GOP, an added feature of Smart Compression, the number of I-frames are automatically reduced in scenes with low motion. Based on the complexity of scenes and motion occurring, such as a store room that has limited entry and exit, up to 70% bandwidth savings can be achieved.

TECHNICAL SPECIFICATIONS

GENERAL

Construction	Aluminum	
Cable Entry (Back Box)	Pendant Through 1.5-inch NPT pendant mount	
Weight (Approximate)	Unit	Shipping
Environmental Pendant	5.2 kg (11.5 lb)	6.2 kg (13.7 lb)
Effective Projected Area (EPA)*	63.5 square inches (without mount), 109.8 square inches (with IWM Series mount)	
*0.8 drag coefficient assumed. Air temperature and wind velocity impact drag coefficient so if a more accurate EPA is required, then the drag coefficient must be determined experimentally.		
Clock	Real time clock	
IR Wavelength	850 nm	
IR Range	150 m	

ALARM

Unsupervised	Detects open or closed alarm state
Input	Two alarms, 3.5 VDC maximum, 3.5 mA maximum
Relay Output	Two outputs, ± 30 VDC maximum, 150 mA maximum

AUDIO

Input/Output	Line level/external microphone input; 1Vp-p maximum signal level
Streaming	Embedded audio

OPERATING TEMPERATURE*

Temperature	Environmental Pendant
Maximum ¹	60°C (140°F)
Minimum ¹	-40°C (-40°F)
Cold Start ²	-40°C (-40°F)
Storage Temperature	-40°C to 60°C (-40°F to 140°F)

* Assumes no wind chill factor.

¹ For outdoor applications.

² Cold starts within 20 minutes at specified temperature.

OPERATING HUMIDITY

Environmental Pendant	0 to 90% RH (condensing)
-----------------------	--------------------------

MECHANICAL

Variable Speed	0.1° to 100°/sec (manual pan speed)
Preset Accuracy	$\pm 0.1^\circ$
Pan Movement	360° continuous pan rotation
Vertical Tilt	+15° to -90° degrees
Maximum Pan Speed	Up to 300° per second
Maximum Tilt Speed	Up to 145° per second
Manual Pan/Tilt Speeds	
Pan	0.1° to 100°/sec manual operation
Tilt	0.1° to 50°/sec manual operation
Preset Speeds	
Pan	300°/sec
Tilt	145°/sec

ELECTRICAL

Ports	RJ-45 connector for 100Base-TX Auto MDI/MDI-X Autonegotiate/manual setting
Cabling Type	Cat5e or better for 100Base-TX
Input Voltage	21 to 32 VAC; 24 VAC nominal 38 to 57 VDC; 48 VDC nominal
Input Power	
24 VAC	1 A (24 VA) maximum (without IR, PTZ, and heater); 3.3 A (80 VA) maximum (with IR, PTZ, and heater)
48 VDC	0.46 A (22 W) maximum (without IR, PTZ, and heater); 1.2 A (57 W) maximum (with IR, PTZ, and heater)
802.3bt (56 V)	0.37 A (20 W) maximum (without IR, PTZ, and heater); 1.1 A (61 W) maximum (with IR, PTZ, and heater)

CERTIFICATIONS/RATINGS

- CE, Class A
- FCC, Class A
- ICES-003, Class A
- UL/cUL Listed
- RCM
- KC
- ONVIF Profile S
- ONVIF Profile G
- ONVIF Profile Q
- ONVIF Profile T
- IEC 62676 Part 5
- Environmental models meet Type 4X and IP66 standards when installed properly

TECHNICAL SPECIFICATIONS

SYSTEM MODEL NUMBERS

Model Number	Resolution	Optical Zoom	Color	Description
P2230L-ESR	2 MPx	30x	Light Gray	Spectra Pro IR Environmental Pendant

RECOMMENDED MOUNTS

IWM-SR, IWM24-SR	Wall mount, with or without integral 24 VAC, 100 VA transformer; can be adapted for corner, parapet, or pole application
WMVE-SR	Environmental wall mount; can also be mounted using a pole
PP350/PP351	Spectra dome parapet; wall/rooftop mount

POWER SUPPLIES

WCS1-4 Model (WCS Series)	Single 24 VAC camera power supply, indoor
ECPS-48VDC-5A	48 VDC indoor power supply
POE190-BT	90 W HPoE 802.3BT single port injector power cord not included

Note: For ease of installation, the Spectra Pro IR Series has a top cover that is hinged. This way, after installation on a mount, while the camera weight is hanging on a mount, wiring connections can be made.

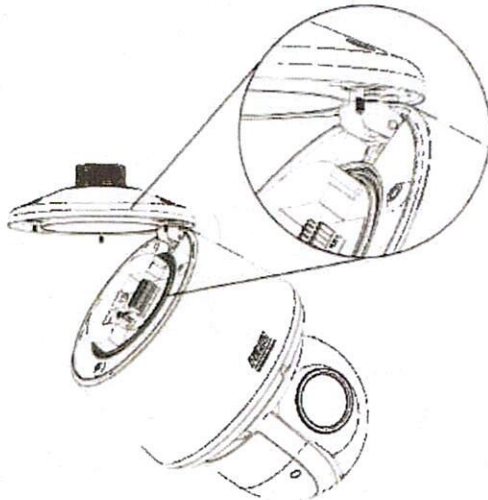

SPECTRA PRO IR SERIES WITH HINGED TOP COVER

Pelco

625 W. Alluvial, Fresno, California 93711 United States
USA & Canada Tel (800) 289-9100 Fax (800) 289-9150
International Tel +1 (559) 292-1981 Fax +1 (559) 348-1120
www.pelco.com

⚠ **WARNING:** Cancer and Reproductive Harm
www.P65Warnings.ca.gov
 ⚠ **ADVERTENCIA:** Cáncer y Daño Reproductivo -
www.P65Warnings.ca.gov
 ⚠ **AVERTISSEMENT:** Cancer et Troubles de
 l'appareil reproducteur - www.P65Warnings.ca.gov

Pelco, the Pelco logo, and other trademarks associated with Pelco products referred to in this publication are trademarks of Pelco, Inc. or its affiliates. ONVIF and the ONVIF logo are trademarks of ONVIF Inc. All other product names and services are the property of their respective companies. Product specifications and availability are subject to change without notice.
 ©Copyright 2021, Pelco, Inc. All rights reserved.



IBR900 Series Ruggedized Router

Compact, ruggedized Gigabit-Class LTE router for advanced in-vehicle and IoT connectivity



Firewall Throughput:
940 Mbps



WAN Connectivity:
4G Cat 11 or Cat 18,
GbE



LAN Connectivity:
Wi-Fi 5, GbE



Management:
NetCloud

The Cradlepoint IBR900 Series Router is a ruggedized Gigabit-Class LTE networking platform that was designed for persistent connectivity across a wide range of in-vehicle and mobile applications as well as portable or fixed IoT installations. The IBR900 Series accommodates environmentally harsh environments while delivering enterprise-class standards of reliability, scalability, comprehensive management, and security.

For organizations that depend on field forces and mobile networks, the Cradlepoint IBR900 Series mobile router with the NetCloud Mobile solution package provides ruggedized and GPS-enabled in-vehicle network solutions that are SD-WAN and SD-Perimeter-capable. With an available Gigabit-Class LTE modem, Gigabit Wi-Fi, and advanced security features, the IBR900 delivers enterprise networking capabilities for mobile applications that require secure, always-on connectivity.

The IBR900 Series with NetCloud IoT Solutions Package provides a compact ruggedized 4G LTE router solution for connecting and protecting IoT devices at scale. With an extensive list of safety and hardening certifications, it can be confidently deployed in the field, in buildings, or in embedded systems to deliver complete visibility, security, and control of connected devices anywhere.

Key Benefits:

- Robust, dependable Gigabit-Class LTE network platform for first responders and commercial fleets
- Ruggedized for vibration, shock, dust, splash, and humidity
- Mobile SD-WAN for optimized multi-link LTE connectivity
- GPS for AVL integration and location tracking to provide current and historic vehicle location
- Dual-modem capability with COR Extensibility Dock for multi-link dependability
- Heatmapping for an LTE signal strength map of all areas a fleet has driven
- WiFi-as-WAN for data-intensive tasks such as video offload

PRODUCT BRIEF ■ IBR900 SERIES

Hardware Specs

Category	Mobile or IoT
Cloud Management	Yes
Wireless Connectivity	LTE
5G Optimized	None
Form Factor	Ruggedized Metal
Ethernet Ports	2 GbE (LAN/WAN switchable)
USB Ports	1
Serial Ports	0
Dual-Modem Support	Yes with COR Extensibility Dock
Network Operator Standards	PTCRB (U.S.), GCF (Worldwide)
Network Operator Certifications	AT&T, Verizon, Telstra
Regions	North America, Latin America, Europe, Africa & Middle East, Asia-Pacific <i>See country and model availability</i>
Public Safety Networks	FirstNet Ready™, Verizon Frontline <i>See data sheet for model applicability</i>
Firewall Throughput	940 Mbps
VPN Tunnel Count	10
Wi-Fi	Dual-band, dual-concurrent; 802.11ac Wave 2 (Wi-Fi 5)
GNSS/GPS	Active
PoE	No
Operating Temperature	-30 °C to 70 °C (-22 °F to 158 °F)
Antennas & Power Adapter Included	IoT Package only

NetCloud Features for Mobile & IoT

NetCloud Service for Mobile provides the enterprise capabilities that organizations need to manage their in-vehicle work while NetCloud Service for IoT provides the reliability, security, management, and data orchestration for IoT applications. Each service includes:

- Centralized endpoint management with insights and visual analytics
- 24x7 enterprise support and limited lifetime warranty
- On-demand training with Cradlepoint University

	IoT	Mobile
Secure Remote Management & Orchestration	●	●
Dynamic Routing Protocols, Traffic Steering & QoS	●	●
Zone-Based Firewall & VPN	●	●
Insights, Alerts & Dashboard Analytics	●	●
Extensibility (SDK, API, third-party integrations)	●	●
Diagnostics & Troubleshooting	●	●
Secure Overlay Perimeter Network	●	●
In-Band & Out-of-Band Management	●	●
Real-Time Troubleshooting Tools	●	●
Modem-Data-Usage Dashboard & Predictive Alerting	●	●
Location Services	●	●
IoT Ecosystem Integration	●	●
Cellular Health, Traffic & Security Dashboards	●	●
Cellular Coverage Map & Location Tracking	●	●
Application-Aware Traffic Steering, QoS, Networking & Firewall	●	●
Web Filtering & Threat Management	●	●

● Included ● Advanced ● Not Supported

[Learn more at cradlepoint.com/ibr900](https://www.cradlepoint.com/ibr900)



DURABOOK
Prepared for the Unexpected



S14I Laptop

One Step Above Semi Rugged

- 14.0" FHD DynaVue® SR display with 1000 nits
- 11th Generation Intel® Core™ Processor
- Wireless Wi-Fi 6 AX201 and Bluetooth® V5.2
- Up to 20 hrs. with 2nd battery
- Dedicated GPS and 4G LTE WWAN
- Customizable multimedia bay



**Dyna
Vue**

S14I Specifications



DURABILITY	<ul style="list-style-type: none"> • MIL-STD 810H certified (Drop, Shock, Vibration, Rain, Dust, Altitude, Freeze/Thaw, High/Low Temperature, Temperature Shock, Humidity) • 4' drop 26 faces • IP 53 certified • Aluminum-magnesium alloy chassis • Port covers • Removable quick-release battery and storage drive • Optional sunlight readable display • Optional swappable battery technology 	SECURITY	<ul style="list-style-type: none"> • Intel® vPro™ Technology (per CPU options) • TPM 2.0 • NIST BIOS compliant • Easy removable SSD • Stealth mode • Kensington lock • Optional smart card reader⁴ • Optional Windows Hello² • Optional night vision mode⁵ • Optional fingerprint scanner • Optional HF RFID/NFC reader^{2,4}
OPERATING SYSTEM	Windows® 10 Pro 64-bit	I/O INTERFACES	<ul style="list-style-type: none"> • USB 3.2 Gen 2 (type A) x 2 • USB 3.2 Gen 2 (type C) x 1 (support DP) • USB 2.0 (type A) x 1 • Audio in/out (combo jack) x 1 • SD card (SDXC) x 1 • 10/100/1000 Ethernet (RJ45) x 1 • VGA port (D-sub, 15-pin) x 1 • HDMI port (type A) x 1 • Serial port (RS232/RS422/RS485 : D-sub, 9-pin) x 1 • SIM card x 1 • DC-In jack x 1 • Optional smart card reader x 1⁴ • Optional docking connector (41-pin Pogo) x 1 • Optional RF antenna pass-through for GPS, WWAN, and WLAN
PROCESSORS	<ul style="list-style-type: none"> • Intel® Core™ i7-1185G7 vPro™ (11th Gen) 3.0GHz processor with Turbo Boost Technology up to 4.8GHz, 12MB cache • Intel® Core™ i7-1165G7 (11th Gen) 2.8GHz processor with Turbo Boost Technology up to 4.7GHz, 12MB cache • Intel® Core™ i5-1145G7 vPro™ (11th Gen) 2.6GHz processor with Turbo Boost Technology up to 4.4GHz, 8MB cache • Intel® Core™ i5-1135G7 (11th Gen) 2.4GHz processor with Turbo Boost Technology up to 4.2GHz, 8MB cache • Intel® Core™ i3-1115G4 (11th Gen) 3.0GHz processor with Turbo Boost Technology up to 4.1GHz, 6MB cache 	MEDIA BAY (One Option Only)	<ul style="list-style-type: none"> • Optional DVD super multi • Optional 2nd battery • Optional media bay storage (SSD)² • Optional ExpressCard 54 x 1 or PCMCIA Type II x 1² • Optional 2nd RJ45 and 2nd serial port (RS232)^{1,2}
GRAPHICS	I7/I5 : Intel® Iris® Xe Graphics i3 : Intel® UHD Graphics Optional NVIDIA® GEFORCE GTX 1050 ^{1,8}	POWER	AC adapter : 100-240V, 50Hz-60Hz, 90W • Optional AC adapter (100-240V, 50Hz-60Hz, 120W), with NVIDIA® VGA Main battery Li-Ion, 10.8V, 4700mAh, 10 hours ⁶ • Optional 2nd battery Li-Ion 10.8V, 4700mAh, 10 hours ⁶ • Optional bridge battery : 5 minutes swap time ⁷
MEMORY	2 slots BGB up to 64GB (2400-3200MHz DDR4)	ENVIRONMENT	<ul style="list-style-type: none"> • Temperature Operating : - 20°C ~ 60°C / - 4°F ~ 140°F Storage : - 51°C ~ 71°C / - 60°F ~ 160°F • Humidity : 5% ~ 95%
STORAGE	256GB NVME PCIE SSD • Optional 512GB/1TB PCIE SSD • Optional OPAL 2.0 SSD • Optional 2nd/3rd storage (SATA SSD) ²	DIMENSION & WEIGHT	<ul style="list-style-type: none"> • 350 mm (L) x 282 mm (W) x 38 mm (H)⁸ • 2.3 kg⁸
DISPLAY	14.0" FHD (1920 x 1080) • Optional 1000 nits DynaVue® sunlight readable display without touch screen • Optional 1000 nits DynaVue® sunlight readable display with capacitive multi-touch screen • User selectable touch mode for Finger/Water, Glove, or Stylus programmable function	WARRANTY	3-year limited warranty standard
AUDIO	<ul style="list-style-type: none"> • Optional integrated microphone³ • Intel® High Definition Audio Compliant • Integrated speaker x 2 • Keyboard volume and mute controls 	<ol style="list-style-type: none"> 1. Not available in combination with Intel® Core™ i3-1115G4 2. Contact your sales representative for feature availability 3. Integrated microphone is available only with web-cam 4. RFID/NFC and smart card reader are mutually exclusive. 5. Night vision mode is available only for sunlight readable display. 6. Tested using the MobileMark 2014 battery life benchmark. Results may vary under different situations including hardware configuration, software, operating conditions, power management settings and other factors 7. The system will stay operating (within 300 seconds in standby mode) when user swaps the battery 8. Weight varies with options. The dimension with optional discrete VGA is 61mm/2.4" (H) 	
CAMERA	<ul style="list-style-type: none"> • Optional integrated 2.0 MP web-cam with shutter design • Optional IR camera for Windows Hello² 		
KEYBOARD & INPUT	2 user-definable keys (P1/P2) • RF signal slide-switch • Standard membrane keyboard with optional LED backlight		
COMMUNICATIONS	<ul style="list-style-type: none"> • Integrated 10/100/1000 Ethernet • Intel® Wi-Fi 6 AX201 (802.11a/b/g/n/ac/ax) • Bluetooth® V5.2 • Optional dedicated GPS module (UBLOX-NEO-M8N) • Optional 4G LTE multi-carrier mobile broadband • Optional RF antenna pass-through for GPS, WWAN, and WLAN 		

DURABOOK
Prepared for the Unexpected

Compliance Matrix

RFP Number: 24-22
RFP Title: Peoria Police Camera Trailer

Customer: City of Peoria
Project:

6/1/22

ITEM #	RFP REFERENCE	DESCRIPTION	COMPLIANCE*				COMMENTS
			EX	F	P	N	
1	SPECIFICATIONS	- Must be on a vehicle-towed or otherwise portable platform.	<input type="checkbox"/>	<input checked="" type="checkbox"/>	<input type="checkbox"/>	<input type="checkbox"/>	
2		- Surveillance, networking, and all other electronic equipment must be self-powered (not reliant on grid power), by means of solar, generator or other means.	<input type="checkbox"/>	<input checked="" type="checkbox"/>	<input type="checkbox"/>	<input type="checkbox"/>	
3		- Surveillance Equipment must include:	<input type="checkbox"/>	<input checked="" type="checkbox"/>	<input type="checkbox"/>	<input type="checkbox"/>	
4		o Onboard DVR/NVR or Video Management Platform:	<input type="checkbox"/>	<input checked="" type="checkbox"/>	<input type="checkbox"/>	<input type="checkbox"/>	
5		▪ Capable of motion or other event activated recording	<input type="checkbox"/>	<input checked="" type="checkbox"/>	<input type="checkbox"/>	<input type="checkbox"/>	
6		▪ Minimum 1 TB storage	<input type="checkbox"/>	<input checked="" type="checkbox"/>	<input type="checkbox"/>	<input type="checkbox"/>	
7		▪ Networking Interface (NIC/LAN Port)	<input type="checkbox"/>	<input checked="" type="checkbox"/>	<input type="checkbox"/>	<input type="checkbox"/>	The NVR includes 2TBs of video storage.
8		▪ On-site User Accessible	<input type="checkbox"/>	<input checked="" type="checkbox"/>	<input type="checkbox"/>	<input type="checkbox"/>	
9		o Password/Encryption Protection	<input type="checkbox"/>	<input checked="" type="checkbox"/>	<input type="checkbox"/>	<input type="checkbox"/>	
10		o Remote Accessibility	<input type="checkbox"/>	<input checked="" type="checkbox"/>	<input type="checkbox"/>	<input type="checkbox"/>	
11		o Capability to be integrated with client on-site Exacq-Vision Client (client supplied licensing)	<input type="checkbox"/>	<input checked="" type="checkbox"/>	<input type="checkbox"/>	<input type="checkbox"/>	
12		o Minimum 1 IP Camera per the below	<input type="checkbox"/>	<input checked="" type="checkbox"/>	<input type="checkbox"/>	<input type="checkbox"/>	Price includes 1 camera however, up to 4 cameras can be installed on the trailer. Pricing for additional cameras is included in your Equipment Proposal.
13		- Camera included with the unit must be capable of:	<input type="checkbox"/>	<input checked="" type="checkbox"/>	<input type="checkbox"/>	<input type="checkbox"/>	
14		o High resolution video (1080p or higher)	<input type="checkbox"/>	<input checked="" type="checkbox"/>	<input type="checkbox"/>	<input type="checkbox"/>	
15		o Night/Infrared video capture	<input type="checkbox"/>	<input checked="" type="checkbox"/>	<input type="checkbox"/>	<input type="checkbox"/>	
16		o Motion or other event activated recording	<input type="checkbox"/>	<input checked="" type="checkbox"/>	<input type="checkbox"/>	<input type="checkbox"/>	
17		o Capable of 360 degree viewing (i.e., 4 cameras/sensors) or Pan-Tilt-Zoom (PTZ)	<input type="checkbox"/>	<input checked="" type="checkbox"/>	<input type="checkbox"/>	<input type="checkbox"/>	
18		- Networking equipment must be able to accommodate all cameras/surveillance equipment and cellular connection	<input type="checkbox"/>	<input checked="" type="checkbox"/>	<input type="checkbox"/>	<input type="checkbox"/>	
19		- Cellular connection must support SIM cards from Verizon, AT&T and T-Mobile	<input type="checkbox"/>	<input checked="" type="checkbox"/>	<input type="checkbox"/>	<input type="checkbox"/>	

Compliance Matrix

RFP Number: 24-22
 RFP Title: Peoria Police Camera Trailer

Customer: City of Peoria
 Project:

6/1/22

ITEM #	RFP REFERENCE	DESCRIPTION	COMPLIANCE*				COMMENTS
			EX	F	P	N	
20		- SIM Card/Cellular Plan can be client supplied or vendor supplied (if vendor supplied response will include associated costs)	<input type="checkbox"/>	<input checked="" type="checkbox"/>	<input type="checkbox"/>	<input type="checkbox"/>	IV&C can supply and install the SIM card, but customer is responsible for data plan and SIM card activation.
21		- Solar power system must be capable of 24 hours backup power in the event solar becomes inoperable/unable to provide charge.	<input checked="" type="checkbox"/>	<input type="checkbox"/>	<input type="checkbox"/>	<input type="checkbox"/>	Should the solar panels become inoperable, the trailer's battery bank can support 5 days of continuous operation. With solar panels fully operational, the trailer will operate continuously during the months of March through October. From November to February, the system will need to be recharged every 2- 3 weeks.
23		- Generator power must be capable of powering the system for 24 hours on single fuel charge	<input type="checkbox"/>	<input type="checkbox"/>	<input type="checkbox"/>	<input type="checkbox"/>	N/A
24		- If both Solar and Generator power are included on the same platform, the generator must also provide charge to the solar batteries when needed to supplement the solar system	<input type="checkbox"/>	<input type="checkbox"/>	<input type="checkbox"/>	<input type="checkbox"/>	N/A
25	WARRANTY	Minimum 3 Year Warranty, Support Agreement, Maintenance Agreement, or other type of Warranty covering System Failure, Equipment Failure and Full Support of both Software and Hardware	<input type="checkbox"/>	<input checked="" type="checkbox"/>	<input type="checkbox"/>	<input type="checkbox"/>	Please see "Warranty Information" section for additional information.
26	TRAINING	Training support shall include all required system training to bring staff to a functional level of system operation. The contractor shall provide training and manuals for all equipment and system operation immediately following system installation.	<input type="checkbox"/>	<input checked="" type="checkbox"/>	<input type="checkbox"/>	<input type="checkbox"/>	Remote training is included for no additional charge. Pricing for optional onsite training is included in your Equipment Proposal.
27		Training for equipment and system operation shall be included in the price of the equipment. The contractor shall provide all training materials in hard and soft copy.	<input type="checkbox"/>	<input checked="" type="checkbox"/>	<input type="checkbox"/>	<input type="checkbox"/>	Please refer to item #26 above.



Warranty Information

Part Description	Warranty Period
MVT-3002-NVR Light Weight Surveillance Trailer Base with NVR Enclosure	3 years
Pelco Spectra® Pro IR Series IP PTZ Outdoor Camera	3 years
Cradlepoint IBR900 Ruggedized 3G/4G/LTE Router	Limited Lifetime Warranty
Rugged Onboard Network Video Recorder	3 years



Industrial Video & Control LIMITED WARRANTY STATEMENT

Industrial Video & Control, from the date of original sale/delivery, warrants that its' products will be free from defects in material and workmanship for the items and period set forth below. Industrial Video & Control will, at its' option, repair or replace any part which, upon examination, inspection, and testing by Industrial Video & Control or an Authorized Warranty Service Dealer, is found to be defective. All transportation costs under the warranty, including shipping of replacement parts, return to the factory, are to be borne and prepaid by the purchaser/owner.

WARRANTY SCHEDULE

<u>Product Line</u>	<u>Coverage Period</u>
IVC MobileVision Products	Three (3) Years

THIS LIMITED WARRANTY SHALL NOT APPLY TO THE FOLLOWING:

- Repairs or diagnostics performed by individuals other than Industrial Video & Control and/or OEM authorized dealers not authorized in writing, by Industrial Video & Control.
- Costs of normal maintenance, adjustments, installation, and start-up.
- Failures caused by cellular reception interference issues, non-line of sight point to point reception issues.
- Failures due to, but not limited to, failure to observe any warnings, misapplication, overloading, normal wear and tear, accident, misuse, abuse, negligence. As with all mechanical devices, the Industrial Video & Control products need periodic part(s) service and replacement to perform well. This warranty will not cover repair when normal use has exhausted the life of a part(s).
- Failures due to, but not limited to, any component that has been modified or altered, installed, commissioned, operated, maintained, serviced, or stored otherwise than in accordance with the manufacturer's recommendations and instructions.
- Damage related to insect infestation and/or caused by birds, rodents, or animals.
- Failures caused directly or indirectly by malfunction of utility (telephone, gas, power, or water) lines or equipment.
- Failures caused by any external cause, impossibility, or act of God.
- Any incidental, consequential or indirect damages of any kind including but not limited to: labor costs, installation costs, transportation charges, custom duties, etc., associated with the replacement or repair of defective parts or equipment failure, caused by defects in materials or workmanship, or any delay in repair or replacement of the defective part(s).
- Telephone, cellular phone, facsimile, internet access or other communication expenses.
- Living or travel expenses of person(s) performing service within the terms of the warranty period.
- Expenses related to "customer instruction", investigative costs, or troubleshooting where no manufacturing defect is found.
- Rental equipment used while warranty repairs are being performed.
- Costs incurred for equipment used for removal and/or re-installation of product(s), (i.e.; cranes, hoists, lifts, etc.)
- Overnight freight costs for replacement part(s).
- Overtime labor.
- Batteries, fuses, light bulbs, tires.

THIS WARRANTY IS IN PLACE OF ALL OTHER WARRANTIES, WRITTEN OR ORAL, EXPRESSED, IMPLIED OR STATUTORY. SPECIFICALLY, INDUSTRIAL VIDEO & CONTROL MAKES NO OTHER WARRANTIES AS TO THE MERCHANTABILITY, FITNESS, OR SPECIFIC PERFORMANCE FOR A PARTICULAR PURPOSE. INDUSTRIAL VIDEO & CONTROL'S ONLY LIABILITY SHALL BE THE REPAIR OR REPLACEMENT OF PART(S) AS STATED ABOVE. IN NO EVENT AND WITHOUT LIMITATIONS, SHALL INDUSTRIAL VIDEO & CONTROL BE LIABLE FOR ANY INCIDENTAL, CONSEQUENTIAL OR PUNITIVE DAMAGES.

Industrial Video & Control Co., LLC
330 Nevada Street Newton, MA 02460
info@ivcco.com | www.ivcco.com
PH:(617)467-3059 FX:(617)687-0751



Training Information

The trailer training session includes an in-depth overview of each of the components installed on the trailer, how to properly deploy, operate, and shutdown/store the trailer, and how to remotely access the cameras using the Video Management Software. A sample training agenda has been included with this proposal as an example of the topics typically covered during a trailer training session.

The training session can be conducted remotely via an online webinar session. Multiple resources, such as pictures, a demo trailer unit, and the Trailer Manual, are used during training to ensure attendees receive a thorough visual understanding of the topics covered. There is no additional charge for remote training sessions. A one-day onsite training session can be conducted in lieu of, or in addition to, remote training. Pricing for an optional onsite training session is included in your Equipment Proposal.

For training on accessing the cameras using the Video Management Software, the trainer will remotely access the customer's Network Video Recorder and cameras and will display the Video Management Software in the webinar session to give the customer a training experience unique to their own trailer system.

Training will conclude with a Q&A session to allow attendees to ask the trainer any outstanding questions. The trainer will also be available after the training session to provide one-on-one instruction and to assist with software and camera settings and configuration, adding/configuring user profiles, setting up software notifications, installation of the Video Management Software's mobile application, etc.

In addition to training, operator's manuals will be provided to the customer and will include a comprehensive Trailer Manual, as well as individual manufacturer's manuals for each of the installed components.

Trailer Training Agenda

Training Topic	Estimated Time	Method/ Resources
Component Overview		
<ul style="list-style-type: none"> • Cameras • Cellular Router • Network Video Recorder • Audio • Lights • Electrical Components <ul style="list-style-type: none"> ○ Inverter ○ Battery Charger/Batteries ○ Solar Charge Controller/Solar Panels ○ Breaker Panel 	15 Minutes	Webinar session using pictures of the trailer or demo trailer as a reference
Deployment Process		
<ul style="list-style-type: none"> • Initial Deployment Procedure <ul style="list-style-type: none"> ○ Wheel chocks ○ Extending outriggers ○ Leveling the trailer ○ Adjusting solar panels ○ Procedure for powering on the trailer ○ Review of all breakers and electrical components ○ LED light control panel ○ Raising/lowering the mast • How to Properly Shutdown/Store the Trailer <ul style="list-style-type: none"> ○ Proper power off procedure ○ Turning off breakers ○ Laptop/NVR power down procedure ○ Lowering the mast ○ Stowing and securing the solar panels, outriggers, etc. • Maintaining/Charging Batteries <ul style="list-style-type: none"> ○ Recharging via 110V AC/connecting to shore power ○ Recharging via solar ○ Low voltage disconnect/reconnect • System Maintenance <ul style="list-style-type: none"> ○ What to regularly inspect when trailer is in use ○ System health check - battery voltage, solar input/output, etc. ○ Recommended tasks for monthly and annual servicing ○ Battery maintenance • Troubleshooting <ul style="list-style-type: none"> ○ Tips for troubleshooting common issues/concerns ○ How/when to contact IVC support for assistance with troubleshooting/service/maintenance 	45 Minutes	Webinar session using pictures of the trailer or demo trailer, and Trailer Manual as a reference
Video Management Software/Remote Camera Access		
<ul style="list-style-type: none"> • Monitoring cameras • Scheduling and triggering recording • Camera configuration/settings • Saving/exporting stored video • Searching recorded video • Monitoring external hard drive capacity • PTZ controls, guard tour, setting positions, etc. • User settings/permissions • Configuration and updates • Monitoring device status 	1 Hour	Webinar session and remote access to customer's Network Video Recorder and Cameras