



19-238

SUBMITTED BY:

C & G Concrete Construction Co.
CONTRACTOR'S NAME

1906 Meadow Ave.
CONTRACTOR'S ADDRESS

East Peoria, IL 61611
CITY, STATE, ZIP

STATE OF ILLINOIS
CITY OF PEORIA
COUNTY OF PEORIA

SPECIFICATIONS, PLANS, MATERIAL
QUANTITIES AND CONTRACT PROPOSAL

FOR

2019 HARRISON IMPACT ZONE SIDEWALKS

TO BE CONSTRUCTED UNDER THE PROVISIONS OF
THE CITY OF PEORIA

BID OPENING: Friday, July 12, 2019, 11:00 A.M.

Bill Lewis

Bill Lewis, P.E., City Engineer

Awarded by City Council on July 23rd, 2019 under Item No. 19-238

**CITY OF PEORIA
CONTRACT**

This agreement, made and entered into this 23rd day of July, 2019, by and between the City of Peoria, an Illinois Municipal Corporation, Party of The First Part, and C & G CONCRETE CONSTRUCTION CO., INC., Party of The Second Part for the improvement known as the 2019 HARRISON IMPACT ZONE SIDEWALKS PROJECT;

WITNESSETH: That for and in consideration of the payments and agreements mentioned in the proposal hereto attached, to be made and performed by the Party of the First Part, and according to the terms expressed in the bond referring to these presents, the Party of The Second Part agrees with said Party of The First Part, at his/their own proper cost and expense to furnish and deliver all the work, materials and supplies in accordance with the specifications contained in said proposal, and in full compliance with all the terms of this agreement, for the amount of EIGHTY-ONE THOUSAND SEVEN HUNDRED THIRTY-FOUR AND NO/100 DOLLARS (\$81,734.00).

IT IS UNDERSTOOD AND AGREED that the instructions to bidders, proposal, bid, specifications, performance bond and maintenance bond are component parts of this Contract and shall be deemed a part hereof. It is also understood and agreed that the contractor shall not assign, transfer, convey or otherwise dispose of this Contract, or his right to execute it, or his right, title or interest in or to it or any part thereof, unless the previous written consent of the City Manager of the City of Peoria shall first be obtained thereto.

EMPLOYEE/EMPLOYMENT RESTRICTIONS – THE CONTRACTOR:

THE CONTRACTOR (hereinafter referred to as "SERVICE PROVIDER") agrees, as a condition of accepting this contract with the City of Peoria, that, for a period of one (1) year following completion of this contract, it shall be prohibited from hiring, directly or indirectly, any City employee or official who was involved, directly or indirectly in: (1) the selection and/or recommendation to select the SERVICE PROVIDER for performance of this contract; (2) coordinating the efforts of the SERVICE PROVIDER in the consummation or completion of this contract; or (3) monitoring or determining the performance of the SERVICE PROVIDER. The SERVICE PROVIDER further acknowledges and agrees that, upon the City's determination that a violation of this provision has occurred, the penalty imposed, at the sole discretion of the City, may include one or more of the following: (1) cancellation of any other contract(s) between the City of Peoria and the SERVICE PROVIDER; (2) disqualification of the SERVICE PROVIDER from bidding or being awarded future contracts with the City of Peoria for a period of two [2] years; and/or (3) payment of liquidated damages to the City of Peoria in the amount of TWENTY FIVE THOUSAND DOLLARS (\$25,000.00). This does not apply to any City Employee involved in the 2011-12 reduction in force; nor does it apply to parties taking the Early Retirement incentive offered by the City from November 1, 2011 through November 1, 2012.

IN WITNESS WHEREOF, the said parties have executed these presents on the date above mentioned.

THE CITY OF PEORIA

BY: *Patricia*
City Manager

ATTEST: *Beth Ball*
City Clerk

EXAMINED AND APPROVED:
Donald B. List
Corporation Counsel

PARTY OF THE SECOND PART

C&G Concrete Construction,co Inc
(name of individual, firm or corporation)

BY: *Rodney Shank V.P.*
(member of firm or officer of corporation)

(If a Co-Partnership)
_____(seal)
_____(seal)

Partners doing business under the firm name
of _____(seal)
(PARTY OF THE SECOND PART)
(If an Individual)
_____(seal)
(PARTY OF THE SECOND PART)

CITY OF PEORIA
PERFORMANCE BOND

KNOW ALL MEN BY THESE PRESENTS, That I/we C & G CONCRETE CONSTRUCTION CO, INC.

an individual, of _____

a co-partnership, of _____

a corporation organized under the laws of the State of _____

as Principal, and _____

a corporation organized and existing under the laws of the State of _____ with authority to do business in the State of Illinois, as Surety, are held and firmly bound unto the City of

Peoria, Peoria County, State of Illinois, in the penal sum of EIGHTY-ONE THOUSAND SEVEN HUNDRED THIRTY-FOUR AND NO/100 DOLLARS (\$81,734.00) lawful money of the United States, well and truly to be paid unto said City of Peoria for the payment of which we bind ourselves, our heirs, executors, administrators, successors, and assigns, jointly, severally, and firmly by these presents.

THE CONDITION OF THE FOREGOING OBLIGATIONS IS SUCH that whereas, the said Principal has entered into a Contract with the City of Peoria for the 2019 HARRISON IMPACT ZONE SIDEWALKS PROJECT in accordance with the terms and conditions of said Contract, which is hereby referred to and made a part hereof as if fully set forth herein;

NOW, THEREFOR, the condition of this obligation is such, that if the above bounden Principal shall well and truly keep, do and perform, each and every, all and singular, the matters and things in said contract set forth and specified to be by said Principal kept, done and performed, at the times and in the manner in said contract specified, or shall pay over, make good and reimburse the City of Peoria, all loss and damage which it may sustain by reason of the failure or default on the part of the Principal so to do, then this obligation shall be null and void; otherwise to remain in full force and effect.

IN WITNESS WHEREOF, we have duly executed the foregoing Obligation this _____ day of _____, 2019.

FOR THE CITY OF PEORIA

EXAMINED AND APPROVED:

Corporation Counsel

Principal

Sureties

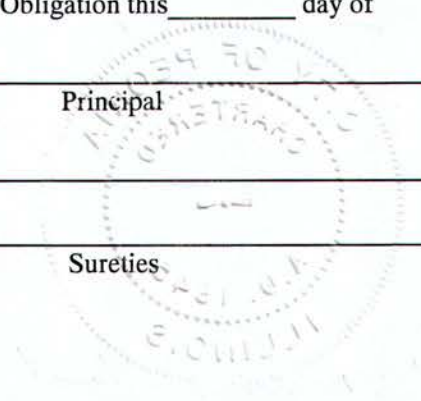

CITY OF PEORIA
PERFORMANCE BOND

Bond #5145799

KNOW ALL MEN BY THESE PRESENTS, That I/we C & G CONCRETE CONSTRUCTION CO. INC.

an individual, of _____

a co-partnership, of _____

a corporation organized under the laws of the State of Illinois

as Principal, and Old Republic Surety Company

a corporation organized and existing under the laws of the State of Wisconsin with authority to do business in the State of Illinois, as Surety, are held and firmly bound unto the City of

Peoria, Peoria County, State of Illinois, in the penal sum of EIGHTY-ONE THOUSAND SEVEN HUNDRED THIRTY-FOUR AND NO/100 DOLLARS (\$81,734.00) lawful money of the United States, well and truly to be paid unto said City of Peoria for the payment of which we bind ourselves, our heirs, executors, administrators, successors, and assigns, jointly, severally, and firmly by these presents.

THE CONDITION OF THE FOREGOING OBLIGATIONS IS SUCH that whereas, the said Principal has entered into a Contract with the City of Peoria for the 2019 HARRISON IMPACT ZONE SIDEWALKS PROJECT in accordance with the terms and conditions of said Contract, which is hereby referred to and made a part hereof as if fully set forth herein;

NOW, THEREFOR, the condition of this obligation is such, that if the above bounden Principal shall well and truly keep, do and perform, each and every, all and singular, the matters and things in said contract set forth and specified to be by said Principal kept, done and performed; at the times and in the manner in said contract specified; or shall pay over, make good and reimburse the City of Peoria, all loss and damage which it may sustain by reason of the failure or default on the part of the Principal so to do; then this obligation shall be null and void; otherwise to remain in full force and effect.

IN WITNESS WHEREOF, we have duly executed the foregoing Obligation this 26th day of July, 2019.

FOR THE CITY OF PEORIA

EXAMINED AND APPROVED:

Donald B. Zist
Corporation Counsel

C & G Concrete Construction Co Inc

Adney Slush V.P.
Principal

Old Republic Surety Company

Blake E. Allison
Sureties

Blake E Allison

STATE OF Illinois)
COUNTY OF Macon) SS

I, Stacy R Standley, a Notary Public in and for said County, in the

State aforesaid, do hereby certify that Blake E Allison,
who is personally known to me to be the same person who signed the above foregoing instrument as the
Attorney in Fact for Old Republic Surety Company,
appeared before me this day in person and acknowledged that he signed the name of

Blake E Allison, thereto, as his Principal, and his own name as Attorney
in Fact, as the free and voluntary act of his said Principal for the uses and purposes therein set forth, and
that he executed the said instrument under authority given him by his said Principal.

Given under my hand and Notarial Seal, this 26th day of July, 2019.

Stacy R Standley

Notary Public





OLD REPUBLIC SURETY COMPANY

POWER OF ATTORNEY

KNOW ALL MEN BY THESE PRESENTS: That OLD REPUBLIC SURETY COMPANY, a Wisconsin stock insurance corporation, does make, constitute and appoint: KEVIN J. BREHENY, RANDY S. CANNADY, TIM R. PATTON, GLENDA HOFFMAN, DANIEL A. MARTINI AND BLAKE E. ALLISON OF FORSYTH, IL.

its true and lawful Attorney(s)-in-Fact, with full power and authority, not exceeding \$50,000,000, for and on behalf of the company as surety, to execute and deliver and affix the seal of the company thereto (if a seal is required), bonds, undertakings, recognizances or other written obligations in the nature thereof, (other than bail bonds, bank depository bonds, mortgage deficiency bonds, mortgage guaranty bonds, guarantees of installment paper and note guaranty bonds, self-insurance workers compensation bonds guaranteeing payment of benefits, asbestos abatement contract bonds, waste management bonds, hazardous waste remediation bonds or black lung bonds), as follows:

ALL WRITTEN INSTRUMENTS IN AN AMOUNT NOT TO EXCEED (\$50,000,000.00) FOR ANY SINGLE OBLIGATION

and to bind OLD REPUBLIC SURETY COMPANY thereby, and all of the acts of said Attorneys-in-Fact, pursuant to these presents, are ratified and confirmed. This appointment is made under and by authority of the board of directors at a special meeting held on February 18, 1982.

This Power of Attorney is signed and sealed by facsimile under and by the authority of the following resolutions adopted by the board of directors of the OLD REPUBLIC SURETY COMPANY on February 18, 1982.

RESOLVED that, the president, any vice-president or assistant vice president, in conjunction with the secretary or any assistant secretary, may appoint attorneys-in-fact or agents with authority as defined or limited in the instrument evidencing the appointment in each case, for and on behalf of the company to execute and deliver and affix the seal of the company to bonds, undertakings, recognizances, and suretyship obligations of all kinds; and said officers may remove any such attorney-in-fact or agent and revoke any Power of Attorney previously granted to such person.

RESOLVED FURTHER, that any bond, undertaking, recognizance, or suretyship obligation shall be valid and binding upon the Company

- (i) when signed by the president, any vice president or assistant vice president, and attested and sealed (if a seal be required) by any secretary or assistant secretary; or
- (ii) when signed by the president, any vice president or assistant vice president, secretary or assistant secretary, and countersigned and sealed (if a seal be required) by a duly authorized attorney-in-fact or agent; or
- (iii) when duly executed and sealed (if a seal be required) by one or more attorneys-in-fact or agents pursuant to and within the limits of the authority evidenced by the Power of Attorney issued by the company to such person or persons.

RESOLVED FURTHER that the signature of any authorized officer and the seal of the company may be affixed by facsimile to any Power of Attorney or certification thereof authorizing the execution and delivery of any bond, undertaking, recognizance, or other suretyship obligations of the company; and such signature and seal when so used shall have the same force and effect as though manually affixed.

IN WITNESS WHEREOF, OLD REPUBLIC SURETY COMPANY has caused these presents to be signed by its proper officer, and its corporate seal to be affixed this 19th day of March, 2018.

OLD REPUBLIC SURETY COMPANY

Assistant Secretary





President

STATE OF WISCONSIN, COUNTY OF WAUKESHA - SS

On this 19th day of March, 2018, personally came before me, Alan Pavlic and Jane E. Cherney, to me known to be the individuals and officers of the OLD REPUBLIC SURETY COMPANY who executed the above instrument, and they each acknowledged the execution of the same, and being by me duly sworn, did severally depose and say: that they are the said officers of the corporation aforesaid, and that the seal affixed to the above instrument is the seal of the corporation, and that said corporate seal and their signatures as such officers were duly affixed and subscribed to the said instrument by the authority of the board of directors of said corporation.

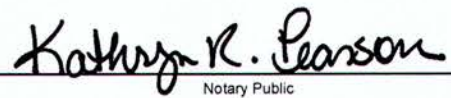

Notary Public

My Commission Expires: September 28, 2018

(Expiration of notary's commission does not invalidate this instrument)

CERTIFICATE

I, the undersigned, assistant secretary of the OLD REPUBLIC SURETY COMPANY, a Wisconsin corporation, CERTIFY that the foregoing and attached Power of Attorney remains in full force and has not been revoked; and furthermore, that the Resolutions of the board of directors set forth in the Power of Attorney, are now in force.

40-1871



Signed and sealed at the City of Brookfield, WI this 26th day of July, 2019.

Assistant Secretary

<u>ITEM</u>	<u>PAGE</u>
SIDEWALK REMOVAL.....	55
SUBBASE GRANULAR MATERIAL.....	55
INLET ADJUSTMENT	56
P.C.C. COMBINATION CURB AND SIDEWALK, 4"	56
P.C.C. SIDEWALK, 4"	56
CONCRETE STEP REMOVAL	56
P.C.C. STEPS	57
INCIDENTAL HOT MIX ASPHALT SURFACING (SPECIAL).....	57
WALL REMOVAL.....	57
TIMBER RETAINNG WALL	58
CURING COMPOUND	59
CONCRETE FIBERS.....	59
SEEDING & MULCHING.....	59
SIDEWALK RAMPS FOR THE DISABLED.....	59
DETECTABLE WARNINGS	60
TIE BARS & DOWEL BARS.....	61

APPENDIX A

EEO DOCUMENTS

EMPLOYER REPORT CC-1.....	64-68
MINORITY AND WOMEN BUSINESS ENTERPRISE DIRECTORY	69
EQUAL EMPLOYMENT OPPORTUNITY	69
MINORITY AND FEMALE WORKFORCE UTILIZATION	69

CONTRACT DELIVERABLES

SUBCONTRACTOR PAYMENT FORM.....	71
MONTHLY WORKFORCE ANALYSIS	72
NOTIFICATION OF CHANGE IN PARTICIPATION	73

MISCELLANEOUS

SAMPLE CONTRACT.....	75
----------------------	----

COMMUNITY DEVELOPMENT BLOCK (CDBG) DOCUMENTS..... 77-99

STANDARDS	PAGE
CURB RAMPS FOR SIDEWALK	100-103
PCC STEPS	104
COMBINATION CONCRETE, CURB & SIDEWALK, 4".....	105
CITY OF PEORIA 6" * 8" PCC DRIVEWAYS.....	106-107

Page intentionally left blank

PROPOSAL ITEMS

STATE OF ILLINOIS
CITY OF PEORIA

NOTICE TO CONTRACTORS

1. Time and Place of Opening Bids.

Sealed proposals for the improvement described herein will be received at the Office of the City Engineer, Public Works Facility, 3505 N. Dries Lane, Peoria, Illinois, until **11:00 A.M., Friday, July 12, 2019** and at that time publicly opened and read.

2. Description of Work.

(A) The proposed improvement is officially known as the **2019 HARRISON IMPACT ZONE SIDEWALKS**.

(B) The proposed improvement consists of removing existing sidewalk, curb, curb and gutter, and replacing with new sidewalk, ADA Ramps, curb, curb and gutter, and all necessary adjustments, incidentals and appurtenances.

3. Instructions to Bidders.

(A) Proposal forms, and specifications for said proposed project may be examined at the Offices of the City Engineer, Public Works Facility, 3505 North Dries Lane, Peoria, IL. Before bid documents may be obtained, contractors must be pre-qualified. Complete sets of proposal forms may be obtained on CD at no charge; contact information must be given in exchange for the CD. Each business may receive one CD at no-cost, or email a request to pwdropbox@peoriagov.org for an electronic proposal form.

(B) All proposals must be accompanied by a proposal guaranty as provided in Section 102 of the "Standard Specifications for Road and Bridge Construction" prepared by the Illinois Department of Transportation: a Bid Bond, or a proposal guarantee of cash, a Bank Cashier Check, or a properly certified check made payable to the City of Peoria, for not less than five percent (5%) of the amount of the bid.

4. Rejection of Bids.

The City of Peoria reserves the right to reject any or all proposals as provided in LRS6 of the "Supplemental Specifications and Recurring Special Provisions" prepared by the Department of Transportation of the State of Illinois, adopted April 1, 2016.

STATE OF ILLINOIS
CITY OF PEORIA

PROPOSAL

1. Proposal of C&G Concrete Construction Co. Inc 1906 Meadow Ave East Peoria, IL 61611
i. (Name and Address of Bidder)
For the improvement, designated in Paragraph 2 below, by the construction of sidewalk, combination curb and sidewalk, combination curb and gutter, curb, gutter flag, driveway pavement, ADA access ramps and adjustments.
2. The contract documents for the proposed improvements are those prepared by the City of Peoria Engineering Department and approved in June 2019 which contract documents are designated as the 2019 Harrison Impact Zone Sidewalks.
3. The specifications herein referred to are the "Standard Specifications for Road and Bridge Construction," prepared by the Department of Transportation of the State of Illinois and adopted by said Department on January 1, 2016. The undersigned agrees to accept, as part of the contract, the Special Provisions contained within this proposal.
4. The undersigned declares that he will comply with the applicable provisions of Section 100, General Requirements and Covenants.
5. The undersigned agrees to complete the work by September 20, 2019 unless additional time is granted in accordance with Article 108.08 of the Specifications. *Time is of the essence.*
6. Accompanying this proposal is a bid bond, certified check, or cashier's check complying with the requirements of the Specifications, made payable to the City Treasurer of the City of Peoria, Illinois. If this proposal is accepted and the undersigned fails to execute a contract and contract bond as required, it is hereby agreed that the check shall be forfeited to the awarding authority.

The amount of the check or draft is \$_____.

Attach Cashier's Check or Certified Check Here

7. The undersigned certifies that it is not delinquent in the payment of any indebtedness, tax, fee or fine owed to the City of Peoria, or in the payment of any tax administered by the Illinois Department of Revenue, and is in compliance with the terms and conditions of Sec. 10-109 of the Peoria City Code and 65 ILCS 5/11-42.1-1.
8. Each pay item shall have a unit price and a total price.
9. The unit price shall govern if no total price is shown or if there is a discrepancy between the product of the unit price multiplied by the quantity.
10. If a unit price is omitted, the total price will be divided by the quantity in order to establish a unit price.
11. A bid will be declared unacceptable if neither a unit price nor a total price is shown.
12. The undersigned firm certifies that it has not been convicted of bribery or attempting to bribe an officer or employee of the City of Peoria, nor has the firm made an admission of guilt of such conduct which is a matter of record, nor has an official, agent, or employee of the firm committed bribery or attempted bribery on behalf of the firm and pursuant to the direction or authorization of a responsible official of the firm. The undersigned firm further certifies that it is not barred from contracting with any unit of Federal, State or local government as a result of a violation of State laws prohibiting bid-rigging or bid-rotating and has not been suspended or debarred from receiving federal funding.
13. EMPLOYEE/EMPLOYMENT RESTRICTIONS – THE CONTRACTOR:

THE CONTRACTOR, (hereinafter referred to as "SERVICE PROVIDER") agrees, as a condition of accepting this contract with the City of Peoria, that, for a period of one (1) year following completion of this contract, it shall be prohibited from hiring, directly or indirectly, any City employee or official who was involved, directly or indirectly in: (1) the selection and/or recommendation to select the SERVICE PROVIDER for performance of this contract; (2) coordinating the efforts of the SERVICE PROVIDER in the consummation or completion of this contract; or (3) monitoring or determining the performance of the SERVICE PROVIDER. The SERVICE PROVIDER further acknowledges and agrees that, upon the City's determination that a violation of this provision has occurred, the penalty imposed, at the sole discretion of the City, may include one or more of the following: (1) cancellation of any other contract(s) between the City of Peoria and the SERVICE PROVIDER; (2) disqualification of the SERVICE PROVIDER from bidding or being awarded future contracts with the City of Peoria for a period of two [2] years; and/or (3) payment of liquidated damages to the City of Peoria in the amount of TWENTY FIVE THOUSAND DOLLARS (\$25,000.00).

This does not apply to any City Employee involved in the 2011-12 reduction in force; nor does it apply to parties taking the Early Retirement incentive offered by the City from November 1, 2011 through November 1, 2012.

14. EEO CERTIFICATION* (Check one):

We are presently applying for the EEO Certification. Employer Report Form (Form CC-1) is completed and enclosed.

Presently, we have the Employer Report Form (Form CC-1) on file with the City of Peoria, Office of Equal Opportunity and have a current Certificate of Compliance Number.

Certificate of Compliance Number: 00129-191231

**Please note there is a \$50.00 processing fee for new and renewal certification requests.*

15. The City of Peoria can increase or decrease this contract up to 25% to meet its budgetary needs.

16. Community Development Block Grant: All Section 3 forms, attached in Appendix A, shall be filled out by the Contractor and returned with the contract prior to final execution.

17. The undersigned submits herewith this Schedules of Prices covering the work to be performed under this contract:

SCHEDULE OF QUANTITIES

Item #	Item	Unit	Quantity	Unit Cost	Total
20100210	TREE REMOVAL, OVER 15 UNITS DIAMETER	UNIT	60	\$40.00	\$2,400.00
20200100	EARTH EXCAVATION	CU YD	168	\$25.00	\$4,200.00
31101000	SUBBASE GRANULAR MATERIAL, TY B	TONS	155	\$20.00	\$3,100.00
42300200	PCC DRIVEWAY PAVEMENT, 6 IN	SQ YD	126	\$75.00	\$9,450.00
42300400	PCC DRIVEWAY PAVEMENT, 8 IN	SQ YD	44	\$80.00	\$3,520.00
42400100	PCC SIDEWALK 4 IN	SQ FT	5,755	\$7.00	\$40,285.00
42400800	DETECTABLE WARNING SURFACES	SQ FT	40	\$25.00	\$1,000.00
44000200	DRIVEWAY PAVEMENT REMOVAL	SQ YD	98	\$18.00	\$1,764.00
44000600	SIDEWALK REMOVAL	SQ FT	1,535	\$2.00	\$3,070.00
60260100	INLET ADJUSTMENT	EACH	1	\$1,000	\$1,000.00
X4080052	INCIDENTAL HOT-MIX ASPHALT, SPL	SQ FT	149	\$10.00	\$1,490.00
X4240010	PCC COMBIN. CURB & SIDEWALK, 4 IN	SQ FT	250	\$10.00	\$2,500.00
PE000001	CONCRETE STEP REMOVAL	SQFT	53	\$5.00	\$265.00
PE000002	CONCRETE STEP	SQ FT	53	\$45.00	\$2,385.00
PE000003	WALL REMOVAL	FOOT	161	\$5.00	\$805.00
PE000004	TIMBER WALL INSTALL	SQFT	150	\$30.00	\$4,500.00

CONTRACTOR'S PROPOSAL TO MAKE ALL IMPROVEMENTS:	\$81,734.00
--	--------------------

The undersigned further agrees that if awarded the contract for the sections contained in the following combinations, he will perform the work in accordance with the requirements of each individual proposal for the multiple bid specified in the schedule below.

(If an individual) Signature of Bidder _____

Business Address _____

(If a partnership) Firm Name _____

Signed by _____
President

Business Address _____

Insert Names _____
and Addresses _____
of all partners: _____

(If a corporation) Corporate Name C&G Concrete Construction Co., Inc.

Signed by Patricia A. Slusher

Business Address 1906 Meadow Ave.
East Peoria, IL 61611

Insert Names
of Officers:

Patricia Slusher
President
Curtis Slusher
Secretary
Judith Slusher
Treasurer

Attest: Curtis Slusher
Secretary



Proposal Bid Bond

RETURN WITH BID

Route
Municipality City of Peoria
Rd. Dist./Township
County Peoria
Section

WE C & G Concrete Construction Co Inc

Old Republic Surety Company

as PRINCIPAL, an as SURETY, are held and firmly bound unto THE CITY OF PEORIA (hereafter referred to as "LA") in the penal sum of 5% of the total bid price...

WHEREAS THE CONDITION OF THE FOREGOING OBLIGATION IS SUCH that, the said PRINCIPAL is submitting a written proposal to the LA acting through its awarding authority for the construction of the work designated as the above section.

THEREFORE if the proposal is accepted and a contract awarded to the PRINCIPAL by the LA for the above designated section and the PRINCIPAL shall within fifteen (15) days after award enter into a formal contract, furnish surety guaranteeing the faithful performance of the work...

IN THE EVENT the LA determines the PRINCIPAL has failed to enter into a formal contract in compliance with any requirements set forth in the preceding paragraph, then the LA acting through its awarding authority shall immediately be entitled to recover the full penal sum set out above...

IN TESTIMONY WHEREOF, the said PRINCIPAL and the said SURETY have caused this instrument to be signed by their respective officers this 12th day of July A.D. 2019

Principal

C & G Concrete Construction Co Inc

By: Rodney Slusher V-President (Signature and Title) By: (Signature and Title)

(If PRINCIPAL is a joint venture of two or more contractors, the company names, and authorized signatures of each contractor must be affixed.)

Old Republic Surety Company

Surety

By: Blake E. Allison (Signature of Attorney-in-Fact)

STATE OF ILLINOIS, COUNTY OF Macon

I, Stacy R Standley, a Notary Public in and for said county, Curtis Slusher and Blake E Allison do hereby certify that

(Insert names of individuals signing on behalf of PRINCIPAL & SURETY)

who are each personally known to me to be the same persons whose names are subscribed to the foregoing instrument on behalf of PRINCIPAL and SURETY, appeared before me this day in person and acknowledged respectively, that they signed and delivered said instruments as their free and voluntary act for the uses and purposes therein set forth.

Given under my hand and notarial seal this 12th day of July A.D. 2019

NOTICE

- 1. Improper execution of this form (i.e. missing signatures or seals or incomplete certification) will result in bid being declared irregular.
2. If bid bond is used in lieu of proposal guaranty check, it must be on this form and must be submitted with bid

My commission expires May 25, 2021

Stacy R. Standley

(Notary Public)





OLD REPUBLIC SURETY COMPANY

POWER OF ATTORNEY

KNOW ALL MEN BY THESE PRESENTS: That OLD REPUBLIC SURETY COMPANY, a Wisconsin stock insurance corporation, does make, constitute and appoint: KEVIN J. BREHENY, RANDY S. CANNADY, TIM R. PATTON, GLENDA HOFFMAN, DANIEL A. MARTINI AND BLAKE E. ALLISON OF FORSYTH, IL.

its true and lawful Attorney(s)-in-Fact, with full power and authority, not exceeding \$50,000,000, for and on behalf of the company as surety, to execute and deliver and affix the seal of the company thereto (if a seal is required), bonds, undertakings, recognizances or other written obligations in the nature thereof, (other than bail bonds, bank depository bonds, mortgage deficiency bonds, mortgage guaranty bonds, guarantees of installment paper and note guaranty bonds, self-insurance workers compensation bonds guaranteeing payment of benefits, asbestos abatement contract bonds, waste management bonds, hazardous waste remediation bonds or black lung bonds), as follows:

ALL WRITTEN INSTRUMENTS IN AN AMOUNT NOT TO EXCEED (\$50,000,000.00) FOR ANY SINGLE OBLIGATION

and to bind OLD REPUBLIC SURETY COMPANY thereby, and all of the acts of said Attorneys-in-Fact, pursuant to these presents, are ratified and confirmed. This appointment is made under and by authority of the board of directors at a special meeting held on February 18, 1982.

This Power of Attorney is signed and sealed by facsimile under and by the authority of the following resolutions adopted by the board of directors of the OLD REPUBLIC SURETY COMPANY on February 18, 1982.

RESOLVED that, the president, any vice-president or assistant vice president, in conjunction with the secretary or any assistant secretary, may appoint attorneys-in-fact or agents with authority as defined or limited in the instrument evidencing the appointment in each case, for and on behalf of the company to execute and deliver and affix the seal of the company to bonds, undertakings, recognizances, and suretyship obligations of all kinds; and said officers may remove any such attorney-in-fact or agent and revoke any Power of Attorney previously granted to such person.

RESOLVED FURTHER, that any bond, undertaking, recognizance, or suretyship obligation shall be valid and binding upon the Company

- (i) when signed by the president, any vice president or assistant vice president, and attested and sealed (if a seal be required) by any secretary or assistant secretary; or
- (ii) when signed by the president, any vice president or assistant vice president, secretary or assistant secretary, and countersigned and sealed (if a seal be required) by a duly authorized attorney-in-fact or agent; or
- (iii) when duly executed and sealed (if a seal be required) by one or more attorneys-in-fact or agents pursuant to and within the limits of the authority evidenced by the Power of Attorney issued by the company to such person or persons.

RESOLVED FURTHER that the signature of any authorized officer and the seal of the company may be affixed by facsimile to any Power of Attorney or certification thereof authorizing the execution and delivery of any bond, undertaking, recognizance, or other suretyship obligations of the company; and such signature and seal when so used shall have the same force and effect as though manually affixed.

IN WITNESS WHEREOF, OLD REPUBLIC SURETY COMPANY has caused these presents to be signed by its proper officer, and its corporate seal to be affixed this 19th day of March, 2018.

Jane E. Chermey
Assistant Secretary



OLD REPUBLIC SURETY COMPANY

Alan Pavlic
President

STATE OF WISCONSIN, COUNTY OF WAUKESHA - SS

On this 19th day of March, 2018, personally came before me, Alan Pavlic and Jane E. Chermey, to me known to be the individuals and officers of the OLD REPUBLIC SURETY COMPANY who executed the above instrument, and they each acknowledged the execution of the same, and being by me duly sworn, did severally depose and say: that they are the said officers of the corporation aforesaid, and that the seal affixed to the above instrument is the seal of the corporation, and that said corporate seal and their signatures as such officers were duly affixed and subscribed to the said instrument by the authority of the board of directors of said corporation.



Kathryn R. Pearson
Notary Public

My Commission Expires: September 28, 2018
(Expiration of notary's commission does not invalidate this instrument)

CERTIFICATE

I, the undersigned, assistant secretary of the OLD REPUBLIC SURETY COMPANY, a Wisconsin corporation, CERTIFY that the foregoing and attached Power of Attorney remains in full force and has not been revoked; and furthermore, that the Resolutions of the board of directors set forth in the Power of Attorney, are now in force.

40-1871



Signed and sealed at the City of Brookfield, WI this 12th day of July, 2019.

ORSC 22282 (3-06)

Jane E. Chermey
Assistant Secretary



CITY OF PEORIA SUBCONTRACTOR UTILIZATION STATEMENT

Section I (select all that apply)

MBE/WBE Subcontractor(s) will be utilized on this project
 Non MBE/WBE Subcontractor(s) will be utilized on this project

Section II

PRIME CONTRACTOR

PROJECT

Name: C&G Concrete Construction Co. Inc.
 Address: 1906 Meadow Ave. East Peoria, IL
 Phone: 309-699-0384
 Contact Person: Patricia Slusher
 Email: tricia@cngconcrete.com
 Ownership Status: MBE WBE M/WBE Non-M/WBE

Name: Harrison Impact Zone
 Total Contract Value: \$81,734.00

Section III: Selected Subcontractors

Subcontractor Name	MBE, WBE or Non M/WBE	Amount	% of Total Contract	Scope of Work
TOTALS				

**If more than seven firms are utilized, please copy the form and attach the additional information.*

Section IV: Subcontractors that submitted bids but were not selected (M/WBE Only)

Subcontractor Name	Scope of Work Bid	Denial Reason

**If more than seven firms submitted quotes, please copy the form and attach the additional information.*

For Office Use Only
 Reviewed by: _____

Donald B. Leist

Section V: Subcontractors Contacted (M/WBE Only)

Subcontractor Name	Method of Contact	Contact Outcome

**If more than seven firms were contacted, please copy the form and attach the additional information.*

Section VI

The City of Peoria is committed to promoting equal opportunity and has established the following subcontractor utilization goals for city funded construction projects: 10% MBE and 5% WBE. Prime Contractors have an obligation to make a good faith effort to advance the city's commitment to increase diversity among the firms working on city construction projects.

This form must be completed and submitted with bid proposals. ALL subcontractors intended for use on this project shall be listed in Section III above; along with the total amount to be paid to the subcontractors; percentage of total contract; and scope of work. If for whatever reason the prime contractor has to utilize a subcontractor not listed above, they must submit a Notification of Change in Participation.

The undersigned certifies that the information included herein is true and correct; the subcontractors listed above have agreed to perform the scope of work described. The undersigned further certifies that it has no controlling, dominating or conflict of interest in any of the listed subcontractors.

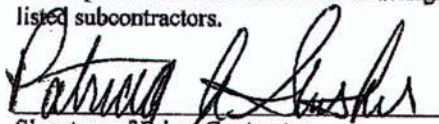
 Signature of Prime Contractor

7-12-2019
 Date

Org.: May 2008
 Revised: Feb. 2011

For Office Use Only
 Reviewed by: Donald P. Leist

**CITY OF PEORIA
M/WBE PARTICIPATION WAIVER REQUEST**

PRIME CONTRACTOR

Name: C&G Concrete Construction Co, Inc.
Address: 1906 Meadow Ave. East Peoria, IL
Phone: 309-699-0384
Contact Person: Patricia Slusher

PROJECT

Name: Harrison Impact Zone

We hereby request to waive all of the MBE and WBE participation goals on the above named project and self-perform all work for the following reason(s). The firm further affirms that the stated reasons and documents provided are true and correct and not misleading: **(CHECK ALL THAT APPLY. SPECIFIC SUPPORTING DOCUMENTATION MUST BE SUBMITTED WHERE INDICATED.)**

- 1. No MBEs/WBEs responded to our invitation to bid. _____
- 2. No subcontracting opportunities exist. (Attach explanation) X
- 3. The award of subcontract(s) is impracticable. (Attach explanation) _____

SIGNED: *Patricia A. Slusher*
(Company Official)

DATE: 7-12-2019

FOR OFFICE USE ONLY

APPROVED DISAPPROVED

REVIEWED BY *Donald B. Leist*

DATE 8/13/19



CONCRETE CONSTRUCTION
CO., INC.

1906 Meadows Avenue / East Peoria, Illinois 61611

Phone (309) 699-0384 or Fax (309) 699-6922

July 12, 2019

RE: Harrison Impact Zone

Dear, Sirs and Madams,

All the Unit Cost items on this HIZ contract is work C&G Concrete performs. Therefore, there is no Subcontracting opportunities at this time, if for any reason the opportunity would arise, we will certainly award to a MBE contractor if they are available.

Regard,

A handwritten signature in black ink, appearing to read 'Patricia Slusher', written in a cursive style.

Patricia Slusher- President

GENERAL CONDITIONS

STATE OF ILLINOIS
CITY OF PEORIA

SPECIAL PROVISIONS

The following Special Provisions supplement the "Standard Specifications for Road and Bridge Construction," adopted January 1, 2016, the latest edition of the "Illinois Manual on Uniform Traffic Control Devices for Streets and Highways" in effect on the date of invitation for bids, the "Standard Specifications for Traffic Control Items," adopted January 1, 2006 and the "Supplemental Specifications and Recurring Special Provisions", adopted January 1, 2019, included herein which apply to and govern the construction of the 2019 Harrison Impact Zone Sidewalks, in the City of Peoria, Peoria County, and in case of conflict with any part of said specifications, the said Special Provisions shall take precedence and shall govern.

DESCRIPTION OF WORK

The proposed improvement consists of removing existing sidewalk, curb, curb and gutter, and replacing with new sidewalk, ADA Ramps, curb, curb and gutter, and all necessary adjustments, incidentals and appurtenances for the areas designated on the following roadway list:

	ROADWAY	FROM	TO
1	W MONTANA ST, SOUTH SIDE	OREGON ST	LIGONIER ST
2	S IDAHO ST, EAST SIDE	TREWYN AVE	MONTANA ST
3	S FOLKERS AVE, WEST SIDE	ARLINGTON ST	GRINNELL ST



The City and Contractor shall coordinate on a weekly basis for which roadway will be under construction at any time.

DEFINITION OF TERMS

Section 101 of the Standard Specifications shall be revised as follows:

Article 101.14 Department. The City of Peoria or its Representative.

Article 101.16 Engineer. The designated employee or representative of the City of Peoria.

The Engineer will not be responsible for construction means, methods, techniques, sequences, or procedures, or for safety precautions and programs.

Article 101.19 Inspector. The authorized representative of the Engineer assigned to make detailed observations or any or all portions of the work or material therefore.

This activity is not to be interpreted as an inspection service, a construction supervision service, or a guaranteeing of the Contractor's performance. The Inspector will not be responsible for construction means, methods, techniques, sequences, or procedures, or for safety precautions and programs. The Inspector will not be responsible for the Contractor's obligation to carry out the work in accordance with the Contract Documents.

FAILURE TO COMPLETE WORK ON TIME

Should the Contractor fail to complete the work by September 20, 2019, the Contractor shall be liable to the City of Peoria at a rate of \$750.00 per day for every day worked over the contract time to cover all costs incurred for engineering, inspection and other expenses incurred by the City of Peoria by reason of the Contractor's failure to complete the work within the specified time, and such amount shall be deducted from the monies due the Contractor, not as a penalty, but as damages sustained.

RESPONSIBILITY FOR DAMAGE CLAIMS

The Contractor shall indemnify and save harmless the CITY OF PEORIA, its officers, agents, and employees against all loss, damage or expense that it or they may sustain as a result of any suits, actions, or claims of any character brought on account of injury to or death of any person or persons, including all persons performing any work under this contract, which may arise in any way (except for a negligent act of the City of Peoria, its officers or employees) in connection with the work to be performed under this contract, including but not limited to, suits, actions or claims arising under "An Act providing for the protection and safety of persons in and about the construction, repairing, alteration or removal of building, bridges, viaducts, and other structures, and to provide for the enforcement thereof," approved June 3, 1907, (740 ILCS 150/1), as amended: the Contractor shall also indemnify and save harmless the CITY OF PEORIA, its officers and employees, from all suits, actions, or claims of any character brought because of any injuries or damages received or sustained by any person, persons, or property, on account of, or in consequence of, any neglect by Contractor or a Subcontractor in safeguarding the work; or through use of unacceptable materials in constructing the work; or because of any act or omission, neglect, or misconduct of said Contractor; or because of

any claims or amounts recovered for any infringements of patent, trademark, or copyright, or from any claims or amounts arising or recovered under the "Workers Compensation Act," or any other law, ordinance, order, or decree, and so much of the money due the said Contractor under and by virtue of his contract as shall be considered necessary by the Department for such purposes, may be retained for the use of the ENGINEERING DIVISION; or, in case no money is due, his surety shall be held until such suits, actions, or claims have been settled and suitable evidence to that effect furnished to the Department.

QUALIFICATION OF CONTRACTORS

Contractors shall be pre-qualified before plans and proposal documents will be provided for bidding. In general, contractors pre-qualified by the State of Illinois, Department of Transportation to perform the work indicated in the proposal will be acceptable to the City of Peoria, Engineering Division; but, the City Engineer reserves the right to refuse to accept a bid from a State-qualified contractor and will state his reasons, in writing, for said refusal if requested by the contractor.

Contractors who have done similar work and an improvement of similar size for the City in the past normally are qualified by their past performances.

Contractors not qualified as indicated above shall be required to submit a listing of jobs of a similar nature with an indication of the dollar value of said jobs and the person or company for whom the work was performed so that a check of the quality of the work can be made, as well as the performance and financial ability of the contractor. The City Engineer will approve or disapprove the contractor, and the decision shall be final. If desired by the contractor, the City Engineer will provide his reasons for disapproving any contractor from bidding on the proposed improvement.

CONTRACTOR'S INSURANCE

The Contractor shall not commence work under this project until he has obtained all insurance required under this paragraph and such insurance has been approved by the City of Peoria, nor shall the Contractor allow any Subcontractor to commence work on his subcontract until all similar insurance required of the Subcontractor has been so obtained and approved by the City of Peoria.

The Contractor shall require Subcontractors, if any, not protected under the Contractor's insurance policies as an additional insured to take out and maintain insurance of such nature in amounts not less than that required of the principal Contractor, excluding Umbrella Coverage and Owner's Protective Liability and Property Damage Insurance, and any and all insurance obtained by any Subcontractor or Subcontractors shall be approved by the City of Peoria.

All policies shall contain provisions to the effect that in the event of payment of any loss or damage the insurers will have no rights of recovery against any of the insured or additional insureds there under.

COMPENSATION INSURANCE

The Contractor shall take out and maintain during the life of this project Worker's Compensation Insurance for all of his employees employed at the site of the project and, in case any work is sublet, the Contractor shall require the Subcontractor similarly to provide Worker's Compensation Insurance for all of the latter's employees unless such employees are covered by the protection afforded by the Contractor, and any such insurance obtained by any subcontractor or subcontractors shall be

approved by the City of Peoria. In case any class of employees engaged in hazardous work at the site of the project is not protected under the Worker's Compensation statute, the Contractor shall provide, and shall cause each Subcontractor to provide adequate insurance coverage for the protection of his employees not otherwise protected, such as accident insurance, and any such insurance shall be approved by the City of Peoria.

PUBLIC LIABILITY AND PROPERTY DAMAGE INSURANCE

The Contractor shall take out and maintain during the life of the project such General Liability, Public Liability and Property Damage Insurance as shall protect him and any Subcontractor performing work covered by this project, from claims for damages for personal injury, including accidental death, as well as from claims for property damages, which may arise from operations under this project, whether such operations be by himself or by any Subcontractors or by anyone directly or indirectly employed by either of them and the amounts of such insurance shall be as follows:

Commercial General Liability Insurance that provides Property Damage and/or Bodily Injury in an amount not less than \$1,000,000 per occurrence and \$2,000,000 aggregate.

OWNER'S PROTECTIVE LIABILITY AND PROPERTY DAMAGE INSURANCE

The Contractor shall obtain Owner's Protective Liability and Property Damage Insurance in an amount not less than \$1,000,000 per occurrence and \$2,000,000 aggregate. If endorsements to the above public liability and property damage insurance policies cannot be made, then separate policies providing such protection must be furnished by the Contractor.

AUTOMOBILE INSURANCE

The Contractor shall take out and maintain during the life of the project such automobile insurance covering all owned and non-owned vehicles as shall protect him and any Subcontractor performing work covered by this project, from claims for damages in an amount not less than \$1,000,000 Combined Bodily Injury and Property Damage.

UMBRELLA COVERAGE

The Contractor shall take out and maintain during the life of the project such Umbrella or Excess Liability coverage as shall protect him and any Subcontractor performing work covered by this project, from claims for damages in an amount not less than \$2,000,000 per occurrence and \$5,000,000 annual aggregate.

ADDITIONAL INSURED ENDORSEMENT

All Liability insurance policies shall name the City of Peoria its officers, directors, employees, agents, representatives, subsidiaries, successors, and assigns, as additional insureds, shall be primary to any other insurance carried by the City of Peoria and shall provide coverage consistent with ISO CG 20 26, and shall maintain the required coverages, naming the City of Peoria as an additional insured, for a period of not less than three years from the date the City of Peoria and Contractor execute an Agreement to Final Quantities.

PROOF OF CARRIAGE OF INSURANCE

The Contractor and all Subcontractors shall furnish the City of Peoria with satisfactory proof of insurance coverage. This shall include an A.M. Best "A" rating before the project begins. If coverage is cancelled or the carrier's rating falls below A.M. Best "A" rated, the City of Peoria shall be notified in writing.

Certificates of insurance are required. The Certificate must state the following "The City of Peoria, its officers, directors, employees, agents, and representatives, are named as Additional Insured on a primary basis for liability arising out of the contractor's operations."

Upon request the Contractor must provide copies of the policies and endorsements, failure to provide the required certificates of insurance shall not operate to invalidate the insurance requirements under this Contract.

GUARANTEE PERIOD

The Contractor warrants all work performed under this contract is free from defects and was performed in accordance with the Contract Documents for a period of one (1) year from the date of agreement of final quantities, as agreed in writing, by the City Engineer after all parties have signed the document. In case of acceptance of a part of the work for use prior to the agreement to final quantities, the guarantee for the part so accepted shall be for a period of one (1) year from the date of such partial acceptance, in writing, by the City Engineer. Work performed due to this warranty requirement shall be guaranteed for a period of one (1) year. The Guarantee Period may be further amended in the Roadwork Special Provision.

PROSECUTION AND PROGRESS OF WORK

Special attention is called to Section 108 of the "Standard Specifications for Road and Bridge Construction," and specifically to Article 108.03, which states that the Contractor shall notify the Engineer at least twenty-four (24) hours in advance of either discontinuing or resuming operations.

If an Engineer or an Inspector for the City of Peoria Engineering Division is not on the job and notification as required has been given, the contractor in charge of the work shall immediately notify the Engineering Division that work has been resumed and request that the Project Engineer in charge of work for the City Engineering Division be notified.

Work performed without proper notification to the City Engineering Division as indicated herein may be rejected by the Engineer for the City of Peoria and no compensation will be made for said work. In addition, the contractor may be required to remove the item of construction at its own expense and replace the item of construction in accordance with the plans and specifications.

EXISTING UNDERGROUND FACILITIES

The City of Peoria assumes no responsibility for the presence, specific size or location of underground distribution systems of the several public utility corporations. No responsibility for the protection of said underground systems will be assumed by the City of Peoria unless such protection is incidental to the protection of the municipally-owned property of the City of Peoria. If such protection is found to be necessary to water mains, gas mains, steam mains, underground electrical distribution systems, underground telephone circuit systems or any other underground systems of non-municipal ownership, the cost of same, in whole or in part, is disclaimed by the City of Peoria.

COOPERATION WITH UTILITY COMPANIES

It is understood and agreed that the contractor has considered, in his bid, all the permanent and temporary utility appurtenances in their present or relocated positions and that no additional compensation will be allowed for any delays, inconvenience or damage sustained by him due to any interference from the said utility appurtenances or the operations of moving them.

All telephone, cableway, gas, water and wire lines, within the limits of the proposed construction owned by various utility companies, are to be moved by the owners of the particular utility involved at the owner's expense.

NOTIFICATION OF UTILITIES PRIOR TO CONSTRUCTION

All utility companies must be notified by the Contractor, in writing, at least one (1) week in advance prior to starting construction so that they will have adequate time to locate and mark their utility locations in the field and twenty-four (24) hours prior to commencing actual construction work. All utility companies must be notified so that they may have personnel on the job site to assist in locating their utility lines and avoid damage to their utilities. Specifically, AmerenCILCO, Comcast Communications, SBC, McLeod Communications and the Illinois-American Water Co., have requested that they be notified prior to the start of construction. A copy of the letter notifying the utility companies of the Contractor's intention to start work must be received by the City of Peoria Engineering Division before the Contractor will be permitted to start construction.

J.U.L.I.E. SYSTEM

The J.U.L.I.E. (Joint Utility Locating Information for Excavators) must be notified prior to starting construction, so that the respective utilities may have adequate time to locate and mark their underground facilities. Phone: 1-800-892-0123 or 811.

Since this is a Citywide program, J.U.L.I.E. will need to be notified before construction on each property.

CERTIFIED PAYROLL REQUIREMENTS

Contractors and subcontractors on public works projects must submit certified payroll records on a monthly basis to the public body in charge of the construction project, along with a statement affirming that such records are true and accurate, that the wages paid to each worker are not less than the required prevailing rate, and that the contractor is aware that filing records he or she knows to be false is a Class B Misdemeanor. The Certified Payroll Records must include, for every worker employed on the public works project, the name, address, telephone number, social security number, job classification, hourly wages paid in each pay period, number of hours worked each day, and starting and ending time of work each day. Certified payrolls are to be submitted on EPrismSoft, per the EEO guidelines outlined in Section VII of the Good Faith Efforts Requirements, herein.

PREVAILING WAGE PROVISION - FEDERAL

The contractor agrees to comply with the requirements of the Secretary of Labor in accordance with the Davis-Bacon Act as amended, the provision of Contract Work Hours and Safety Standards Act, the Copeland "Anti-Kickback" Act (40 US 276a-276a-5; 40 USC 327 and 40 USC 276c) and all other applicable Federal, state and local laws and regulations pertaining to labor standards insofar as those acts apply to the performance of this contract. The contractor shall maintain documentation which demonstrates compliance with hour and wage requirements of this part. Such documentation shall be made available to the City to review upon request.

The contractor agrees that all subcontractors engaged under contracts in excess of \$2,000.00 for construction, renovation or repair work financed in whole or in part with assistance under this contract, shall comply with Federal requirements adopted by the City pertaining to such contracts and with the applicable requirements of the regulations of the Department of Labor, under 29 CFR Parts 1, 3, 5 and 7 governing the payment of wages and ratio of apprentices and trainees to journey workers; provided, that if the wage rates higher than those required under the regulations are imposed by state or local law, nothing hereunder is intended to relieve the contractor of its obligation, if any, to require payment of the higher wage. The contractor shall cause or require to be inserted in full, in all such contracts subject to such regulations, provisions meeting the requirements of this paragraph.

This contract will adhere to Federal Davis-Bacon Act wage rates and definitions.

It shall be the contractor's responsibility to monitor the prevailing wages and adjust his payroll accordingly as soon as any rates are revised by the Federal Department of Labor.

"General Decision Number: IL20190014 06/21/2019

Superseded General Decision Number: IL20180014

State: Illinois

Construction Types: Heavy and Highway

Counties: Fulton, Hancock, Henderson, Knox, McDonough, Mercer, Peoria, Stark, Tazewell and Warren Counties in Illinois.

KNOX, PEORIA, TAZEVELL (N 1/3) & WARREN COUNTIES:

HEAVY CONSTRUCTION PROJECTS (including Sewer & Water Line Construction & Drainage Projects) & HIGHWAY CONSTRUCTION

PROJECTS (excluding tunnels, building structures in rest area projects, and railroad construction; bascule, suspension & spandrel arch bridges; bridges designed for commercial navigation; bridges involving marine construction, other major bridges).

Note: Under Executive Order (EO) 13658, an hourly minimum wage of \$10.60 for calendar year 2019 applies to all contracts subject to the Davis-Bacon Act for which the contract is awarded (and any solicitation was issued) on or after January 1, 2015. If this contract is covered by the EO, the contractor must pay all workers in any classification listed on this wage determination at least \$10.60 per hour (or the applicable wage rate listed on this wage determination, if it is higher) for all hours spent performing on the contract in calendar year 2019. If this contract is covered by the EO and a classification considered necessary for performance of work on the contract does not appear on this wage determination, the contractor must pay workers in that classification at least the wage rate determined through the conformance process set forth in 29 CFR 5.5(a)(1)(ii) (or the EO minimum wage rate, if it is higher than the conformed wage rate). The EO minimum wage rate will be adjusted annually. Please note that this EO applies to the above-mentioned types of contracts entered into by the federal government that are subject to the Davis-Bacon Act itself, but it does not apply to contracts subject only to the Davis-Bacon Related Acts, including those set forth at 29 CFR 5.1(a)(2)-(60). Additional information on contractor requirements and worker protections under the EO is available at www.dol.gov/whd/govcontracts.

Modification Number	Publication Date
0	01/04/2019
1	03/29/2019
2	04/12/2019
3	05/03/2019
4	05/10/2019
5	05/31/2019
6	06/14/2019
7	06/21/2019

CARP0004-009 05/01/2019

HENDERSON and MERCER COUNTIES

	Rates	Fringes
CARPENTER.....	\$ 32.50	28.85

CARP0174-003 05/01/2019

STARK COUNTY

	Rates	Fringes
CARPENTER.....	\$ 36.00	30.44

CARP0237-003 05/01/2019

FULTON and TAZEWELL (Southern 2/3) COUNTIES

	Rates	Fringes
CARPENTER.....	\$ 35.43	28.77

CARP0237-013 05/01/2017		

FULTON, KNOX, PEORIA, AND TAZEWELL (Northern 1/3) COUNTIES

	Rates	Fringes
CARPENTER.....	\$ 34.04	26.47
PILEDRIVERMAN.....	\$ 35.04	26.47

CARP0270-010 05/01/2017		

MCDONOUGH AND WARREN COUNTIES

	Rates	Fringes
CARPENTER.....	\$ 34.54	25.97
PILEDRIVERMAN.....	\$ 35.54	25.97

CARP0270-011 05/01/2017		

HANCOCK COUNTY

	Rates	Fringes
CARPENTER.....	\$ 32.15	25.97
PILEDRIVERMAN.....	\$ 33.15	25.97

ELEC0034-006 03/01/2018		

FULTON (Fairview, Farmington, Joshua, Canton, Orion, Putnam, Buckheart, Banner, Farmers, Bernadotte, Lewistown, Liverpool, Vermont, Pleasant, Isabel, Waterford, Astoria, Woodland, and Kerton Twps), PEORIA, STARK (West Jersey, Essex, and Valley Twps), & TAZEWELL Counties

	Rates	Fringes
ELECTRICIAN.....	\$ 36.51	21.19

ELEC0034-007 03/01/2018		

FULTON (Cass, Deerfield, Ellisville, Harris, Lee, Union, Young, & Hickory Twps), HENDERSON, KNOX, MCDONOUGH (Blandinsville, Prairie City, Emmet, Tennessee, Scotland, Sciota, Bushnell, Chalmers Twps), MERCER (Ohio Grove, North Henderson, and Suez twps), and WARREN Counties

	Rates	Fringes
ELECTRICIAN.....	\$ 32.00	19.88

ELEC0051-002 03/04/2019		

FULTON, HANCOCK, HENDERSON, KNOX, MCDONOUGH, MERCER (N. Henderson & Suez Twps), PEORIA, STARK, TAZEWELL, and WARREN COUNTIES

	Rates	Fringes
Line Construction		
Groundman/Equipment Operator (All crawler type equipment larger than D-4, 15 ton crane or larger).....	\$ 46.47	32%+6.00
Groundman/Truck Driver.....	\$ 35.33	32%+6.00
Lineman and Substation Technician.....	\$ 51.67	32%+6.00

 ELEC0145-006 06/05/2017

MERCER COUNTY (Except Ohio Grove, North Henderson, and Suez Twps)

	Rates	Fringes
CABLE SPLICER.....	\$ 35.50	21.46
ELECTRICIAN.....	\$ 34.50	21.43

 ELEC0145-007 12/03/2018

MERCER COUNTY (Except North Henderson and Suez Twps)

	Rates	Fringes
Line Construction		
Cable Splicer.....	\$ 44.72	33% + 5.75
Dynamiter.....	\$ 37.01	33% + 5.75
Groundman Equipment Operator.....	\$ 35.08	33% + 5.75
Groundman Truck Driver.....	\$ 30.50	33% + 5.75
Groundman.....	\$ 29.24	33% + 5.75
Lineman, Technician, Heavy Equipment Operator.....	\$ 44.32	33% + 5.75

FOOTNOTE:
 A. PAID HOLIDAYS: Memorial Day, Independence Day, Labor Day, and Thanksgiving Day

 * ENGI0150-021 06/01/2019

MERCER COUNTY

	Rates	Fringes
OPERATOR: Power Equipment		
Group 1.....	\$ 36.00	33.30
Group 2.....	\$ 35.00	33.30
Group 3.....	\$ 32.35	33.30
Group 4.....	\$ 31.30	33.30

POWER EQUIPMENT OPERATOR CLASSIFICATIONS

GROUP 1: Crane (Friction or Hydraulic, regardless of size or attachments); Tow or Push Boat

GROUP 2: Asphalt Heater-Planer Unit; Asphalt Paver; Asphalt Paver Screed; Asphalt Plant; Automatic Curbing Machine; Backfiller (throw bucket); Blastholer Self-Propelled Rotary Drill or Similar Machines; Boom Tractor or Side Boom; Boring Machine (Directional, Vertical or Horizontal); Building Hoist (1,2 or 3 drums); Caisson Auguring Machines; Central Redi-Mix Plant; Chip Spreader; Cleaning & Priming Machine; Combination Backhoe Front End Loader; Combination Concrete Finishing Machine and Float; Concrete Breaker or Hydro-Hammer; Concrete Conveyor or Pump; Concrete Paver; Concrete Spreader; Concrete Wheel Saw (Large self-propelled); Crusher (Stone, Concrete, Asphalt, etc.); Curing-Tinning Machine; Dipper Dredge Crane man; Dipper Dredge Operator; Dual Purpose Truck (Boom, Winch, etc.); Excavator; Farm-Type Tractor Operating Scoop or Scraper or with Power Attachment; Forklift (6000 lb. capacity); Grader, Motor Grader, Motor Patrol, Auto Grader, Form Grader, Pull Grader, Sub Grader, Elevating Grader; Group Equipment Greaser; Guard Rail Post Driver; Hoists; Hydraulic Dredge Leverman or Engineer; Hydro-Vac Truck Mounted or Pull Type, and Similar Equipment; Laser Screed; Loader (Track, Rubber Tire or Articulated); Locomotive Engineer; Mechanic-Welder; Mechanical Loaded Log Chippers or Similar Machines; Milling Machine; Mucking Machine; Pile Driver; Pipe Bending; Pug Mill; Road Widener-Shoulder Spreader; Scraper (self-propelled); Self-Propelled Roller or Tire Roller (on Asphalt or Blacktop), Sheep Foot or Pad Foot Compactor; Shovel; Slip Form Paver; Steel Track-Type Tractor (Dozer, Push Cat, etc.); Transfer or Shuttle Buggy; Trenching Machine (40 H.P. & over); Work Boat.

GROUP 3: Articulated Off-Road Haul Unit; Asphalt Booster; Boiler (Engineer or Fireman); Conveyor Over 20 H.P.; Distributor; Driver on Truck Crane or Similar Machines; Elevator; Farm-Type Tractor (Without Power Attachment); Fireman & Pump Operator at Asphalt Plant; Forklift (Less than 6000 lb. capacity); Grout Pump; Light Plant; Mechanical Broom; Mud Jack; Self-Propelled Roller (Other than listed in Group 2); Straddle Carrier; Trench Machine (Under 40 H.P.).

GROUP 4: Air Compressor (400 C.F.M. or over); Compact Loader (Rubber Tire, Track & Utility); Engine Driven Welding Machine; Mechanical Heater (other than steam boiler); Small Outboard Motor Boat (Safety Boat & Life Boat); Water Pump (More than one well point pump).

ENGI0649-002 04/01/2018

FULTON, HANCOCK, HENDERSON, KNOX, MCDONOUGH, PEORIA, STARK, TAZEWELL, and WARREN COUNTIES

	Rates	Fringes
OPERATOR: Power Equipment		
Group 1.....	\$ 40.02	33.03+A
Group 2.....	\$ 37.08	33.03+A
Group 3.....	\$ 32.22	33.03+A

POWER EQUIPMENT OPERATOR CLASSIFICATIONS

GROUP 1: Cranes: Overhead Cranes; Hydro Crane; Shovels; Crane type Backfiller; Tower Cranes-Mobile, Crawler, Stationary; Derricks, Hoist (3 drum); Draglines; Drott Yumbo & similar types considered as Cranes; 360 Degrees Swing Excavator, Backhoe; Derrick Boats; Pile Driver and Skid Rigs; Clam Shell; Locomotive Cranes; Road Pavers (Single Drum, Dual Drum, Tri Batcher); Motor Patrol & Power Blades (Dunmore, Elevating & similar types); Mechanics; Central Concrete Mixing Plant Operator; Asphalt Batch Plant Operator and Plant Engineer; Gradall; Caisson Rigs; Skimmer Scoop, Koehring Scooper; Dredges (all types); Hoptoe; All Cherry Pickers; Work Boat; Ross Carrier; Helicopter; Dozer; Tournadozer; Tournapulls (all & similar types); Concrete and all recycle machines, Multiple Unit Earth Movers; 75 cents per hour for each scoop over one; Scoops (all sizes); Pushcats; Endloaders (all types); Asphalt Surfacing Machine; Slip Form Paver; Rock Crusher; Material Crusher (outside pits and quarries); Screening Plants (outside pits and quarries); Tunnel Boring Machine; Heavy Equipment Greaser (Top Greaser on Spread); CMI, Auto Grade, CMI Belt Placer (3 track & similar types); Side Booms; Starting Engineer on Pipeline or Construction (eleven 11 pieces or more); Asphalt Heater & Planer Combination; Wheel Tractors with Dozer, Hoe or End Loader attachments; CAT Earthwork Compactors and similar types; Blaw Knox Spreader & similar types; Trench Machines; Pump Crete, Belt Crete, Squeeze Crete, Screw Type Pumps & Gypsum; Creter Crane; Concrete Pump Truck; Formless Finishing Machines; Flaherty Spreader or similar types; Screedman on Laydown Machine; Vermeer Concrete Saw; Laser Screed; Span Saw; Dredge Leverman; Dredge Engineer; Lull or similar type; Hydro-Boom Truck; Guard Rail Machine.

GROUP 2: Bulker & Pump; Power Launches; Boring Machine & Pipe Jacking Machine; Dinkeys; Carts, powered haul unit for a boring machine; P-H one Pass Soil Cement Machines and similar types; Wheel Tractor; Back Fillers; Euclid Loader; Fork Lifts; Jeep with Ditching Machines or other attachments; Tuneluger; Automatic Cement & Gravel Batching Plants; Mobile Drills Soil Testing and similar types); Pugmill with Pump; All 1 and 2 Drum Hoists; De-watering Systems; Straw Blower; Hydro Seeder; Bump Grinders, Self Propelled; Assistant Heavy Equipment Greaser; Apsco Spreader Tractors (Track-Type w/o Power Units pulling Rollers); Rollers on Asphalt, Brick, or Macadam; Concrete Breakers; Concrete Spreaders; Cement Strippers; Cement Finishing Machines & CMI Texture & Reel Curing Machines; Vibro-Tampers & similar types self-propelled; Mechanical Bull-Floats; Self-Propelled Concrete Saw; Truck Mounted Power Saws; Curb Cutters; Mixers over 3 bags to 27E; Winch & Boom Trucks; Tractor pulling Power Blade or Elevating

Grader; Porter Rex Rail; Clary Screed; Mule pulling Rollers; Pugmill w/o Pump; Barber Greene or similar Loaders; Track Type Tractor with power unit attached; Fireman; Spray Machine on paving; Curb Machine; Paved Ditch Machine; Power Broom; Self-Propelled Sweepers; Self-Propelled Conveyors; Power Subgrader; Oil Distributor; Straight Tractor; Truck Crane Oiler; Truck Type Oilers; Directional Boring Machine; Horizontal Directional Drill; Articulating End Dump Vehicles; Starting Engineer (6 to 10 pieces).

GROUP 3: Straight Framed Truck and Truck Mounted Vac Unit, Starting Engineer (3 to 5 pieces); Trac Air Machine w/o attachments; Rollers, 5 tons & under on earth & gravel; Form Grader; Bulk Cement Plant; Oilers.

- Escalated Rate on Crane, Derrick Booms, and Tower Cranes: Additional \$1.00 per hour over scale when Crane or Derrick is positioned 50 ft. or more above adjacent ground level or water level. \$.05 per hour, per foot, over 90 feet including jib. \$0.02 per hour, per ton - over 50-ton capacity.

- Operating engineers who operate Lattice Boom Crawler Cranes, Lattice Boom Truck Cranes, Telescopic Boom Cranes less than 17.5 Tons, Tower Cranes, Overhead Cranes and have been Certified by the National Commission for the Certification of Crane Operators on the equipment they operate shall receive \$1.60 per hour over scale.

A. On designated Hazardous Waste jobs, operators shall receive:
 Level A add \$4.00 to the appropriate group rate; Levels B and C add \$3.00 to the appropriate group rate; and Level D add \$2.00 to the appropriate group rate.

 IRON0046-005 05/01/2017

FULTON COUNTY (Southern tip including Marbletown Astoria, & Sumnum Twps)

	Rates	Fringes
IRONWORKER.....	\$ 32.52	25.45

 IRON0111-004 07/01/2018

KNOX (Galesburg and area North thereof), MERCER (except Southwest Part), and WARREN (Northwest Part) COUNTIES

	Rates	Fringes
IRONWORKER.....	\$ 31.75	25.52

 IRON0112-004 05/01/2018

FULTON (Eastern 2/3), KNOX (South and East of Galesburg),

PEORIA, STARK, and TAZEWELL COUNTIES

	Rates	Fringes
IRONWORKER.....	\$ 37.44	28.07

IRON0577-006 08/01/2018		

FULTON (North of Summum & Marbletown Twps, West 1/3), HANCOCK, HENDERSON, KNOX (West and Southwest of Galesburg), McDONOUGH, MERCER, and WARREN (except Northwest Part) COUNTIES

	Rates	Fringes
IRONWORKER.....	\$ 26.25	23.10

LABO0165-002 05/01/2019		

PEORIA and TAZEWELL (Northwest) COUNTIES

	Rates	Fringes
LABORER		
Group 1.....	\$ 30.02	31.92
Group 2.....	\$ 30.32	31.92
Group 3.....	\$ 30.77	31.92

LABORER CLASSIFICATIONS

GROUP 1 - General Laborer - Laying of temporary gas, oil, air, and water lines; All Laborer Work pertaining to Asphalt and Asphalt Plants if needed; Waterproofing Membrane Systems for bridge decks and waterproofing for box culverts on site; Laying, placing, and installation of all steel casing, corrugated casings, multiple plate and precast concrete and all other material used for casing, tunnels and tunnel lining; Removal of snap ties, the placing and removing and tending of barricades, concrete barricade wall, flares and signal lights; Maintenance of Nelson Heaters; Dirt fill jobs, spotter and grade employee and signal employee; Scaffolding; Temporary Fencing; Placing of Concrete to grade by any mode or method; Carpenter Tenders, the conveying, handling, unloading and loading, hoisting, assorting of all lumber, all laborer work required around carpenters including the clean up after carpenters; Horizontal Directional Drill Locator; Waterproofing with cold stuff; Bricklayer Tenders; Cement Mason Tender; Curing all concrete by hand method; Drive stakes and string lines for all machinery; Concrete Form Dismantlers; Handling and maintaining all lights; flares and flasher flares; Flagman; Landscaping on all jobs, the loading, unloading, distribution, planting, and placing of trees, shrub, sod, and seeding on work covered by the agreement; Covering of Concrete in any manner; High Pressure Nozzle (water blast); Pile Driver Tenders; Surveyor Helper; Tool Crib Man; Water Carrier; Expansion joint assembler; All other excavating; Deck Hand, Dredge Hand, and Shore Laborer; Unloading and Distributing of

Rebars; All Power Operated Tools and Chain Saws; Curb Asphalt Maching Operator; Asphalt Kettlemen and Carriers; Waterproofing with hot stuff; Cement Men and Sack Shakers; Chipping Hammer Man; Kettlemen and Carriers or men handling hot stuff; Powder Man Helper; Power Concrete Saw; Power Form Tampers; Rig Men; Signaling and spotting of rigs and equipment; Walk behind concrete breaker; Stripping Concrete Forms with composite crew of laborers and carpenters; all other work not listed below

GROUP 2 - Skilled Laborer - Jackhammer & Drill Operator; Gunite Pump and Pot Man; Puddlers, Vibrator Men; Wire Fabric Placer; Sandblast Pump and Pot Man; Strike Off Concrete; Unloading, handling and carrying of all creosoted piles, ties, or timer; Concrete Burning Bars; Power Wheelbarrows or Buggies; Asphalt Raker; Bricksetters; Cutting Torchmen (elec. and acetylene); Men setting lines to level forms; Form Setters; Gunite Nozzle Man and Sandblasting Nozzle Man; Powder Man; Rip-rapping (by hand)

GROUP 3 - Abestos Abatement Worker; Hazardous Waste Worker (including maintaining of manifest sheet); Lead Base Paint Abatement Worker

LABO0231-002 05/01/2018

FULTON and TAZEWELL (Southeast) COUNTIES

	Rates	Fringes
LABORER.....	\$ 32.61	27.59

LABO0231-005 05/01/2019

HANCOCK AND MCDONOUGH COUNTIES

	Rates	Fringes
LABORER.....	\$ 29.00	25.78

LABO0309-003 01/01/2019

MERCER COUNTY

	Rates	Fringes
LABORER		
GROUP 1.....	\$ 28.13	21.07
GROUP 2.....	\$ 28.63	21.07
GROUP 3.....	\$ 29.26	21.07

LABORER CLASSIFICATIONS

GROUP 1: Flagman, Dumpman, Spotter, Broom Man, Removal of Trees, Fencing Laborers, Cleaning of Forms or Lumber (In Bone Yard), Moving and/or Maintenance of Flares and Barricades, Operation of all Hand, Electric, Air, Hydraulic, or Mechanically Powered Tools Under the Jurisdiction of the Laborers; Including Jackhammers,

Tampers; Air Spades, Augers, Concrete Saws, Chains Saws, Utility Saws, Rock Drills, Vibrators, Mortar Mixer, Power and Hand Saw (When Cleaning Timber), General Laborers (Not Elsewhere Covered), Craft-Tender, Material Checker, Material Handler, Form Handler, Concrete Dumper, Puddler, Explosives Handler, Center Strip, Reinforcing in Concrete, Wire Mesh Handler and Installer, Prime Mover or Any Mechanical Device Taking the Place of Concrete Buggy or Wheel-Barrow, Sandpoint Setter, Asphalt Kettleman, Sheetting Hammer Drivers, Laying and Joining of telephone Conduit, Gas Distribution Men, Pipe Setter On laterals, Drain Tiles, Culvert Pipe, and Storm Sewer Catch Basin Leads, Catch Basins, Manholes, Batch Dumpers, Tank Cleaners, Cofferdam Worker, Bankman On Floating Plant, Jointman with Pipelayers. Back-Up Man (Corker, Joint Maker) With Pipe Setter on Sewer and Water Mains, Batterboard Man or Laser Operator on Sewer and Water Main, Laborer in Ditch, or Tunnel, on Sewer or Water Mains and Telephone Conduit, Cutters, Burners, Torchman, Gravel Box Man, Asphalt Plant Laborer, Concrete Plant Laborer, Deck Hand, Unloading of Steel and Rebar, Laser Beam Operator, Wrecking Laborers

GROUP 2 - Asphalt Raker or Luteman, Head Form Setter, Head Dynamite Man (Powderman) Head String or Wireline Man (On Paving), Pipe Setter On Sewer or Water Main, Gunnite Nozzie Man, Asphalt Or Concrete Curb Machine Operator, Head Grade Man, Head Tunnel Miner, Concrete Burning Machine Operator, Coring Machine Operator, Welder, Asbestos Abatement and Hazardous Waste Workers

GROUP 3 - Concrete Specialist

LABO0538-001 05/01/2019

HENDERSON, KNOX, WARREN, AND STARK (WEST) COUNTIES

	Rates	Fringes
LABORERS		
General Laborer.....	\$ 29.49	24.83
Skilled Laborer.....	\$ 30.49	24.83

LABORER CLASSIFICATIONS

General Laborer: All classifications not listed below.

Skilled Laborer: Flaggers; Traffic Control and all associated work; Handling of materials treated with oil, creosote, asphalt and/or foreign material harmful to skin or clothing; Track Laborers; Chloride Handlers; Unloading and Laborers with Steel Workers and Re-bars; Concrete Workers (wet); Batch Dumpers; Mason Tenders; Kettle and Tar Men; Plastic Installers; Scaffold Workers; Motorized buggies or motorized unit used for wet concrete or handling of building materials; Laborers with de-watering systems; Sewer workers plus depth; Vibrator Operators; Motor Mixer Operators; Cement Silica, clay, fly ash, lime and plasters, handlers (bulk or bag); Cofferdam Workers plus depth; Concrete paving, placing, cutting and tying of reinforcing;

Deckhand, dredge hand and shore laborers; Backmen on floating plant; Asphalt Workers with machine and layers; Grade Checker; Power Tools; Stripping of all concrete forms except paving forms, dumpmen and spotters, when necessary; Caisson Workers plus depth; Gunnite Nozzle Men; Tunnel Helpers in free air; Rod and Chainmen; Welders, Cutters, Burners, and Torchmen; Chainsaw Operator; Paving Breaker, Jackhammer and Drill Operator, Layout man and /or Tile Layer; Steel Form Setters - street and highway, Air Tamping Hammerman; Signalman on Crane Concrete Saw Operator; Screedman on Asphalt Pavers; Front End Man on Chip Spreader; Multiple Concrete Duct; Luteman, Asphalt Raker; Curb Asphalt Machine Operator.

LABO0996-003 05/01/2018

STARK COUNTY (East)

	Rates	Fringes
LABORER		
GROUP 1.....	\$ 32.73	23.74
GROUP 2.....	\$ 33.73	23.74

LABORER CLASSIFICATIONS

GROUP 1: All classifications not listed below

GROUP 2: Dynamite Man; Asbestos Abatement Worker and Hazardous Waste Worker; and Lead Base Paint Worker

PAIN0030-010 07/01/2018

BUREAU, FORD, HANCOCK, LA SALLE, LIVINGSTON, MCDONOUGH, MCLEAN, PUTNAM AND STARK COUNTIES

	Rates	Fringes
PAINTER		
Brush, Roller, Pressure		
Roller, Spray, Airless		
Spray, Sandblasting,		
Taper, Drywall		
Taper/Finisher, Structural		
Steel, and Bridges.....	\$ 36.85	21.80

PAIN0157-001 07/01/2018

FULTON, MARSHALL, MASON, PEORIA, SCHUYLER, TAZEWELL AND WOODFORD COUNTIES

	Rates	Fringes
PAINTER		
Brush, Spray, Pressure		
Roller, Sandblasting,		

Bridges, & New Structural Steel Work.....	\$ 36.85	21.80
--	----------	-------

PAIN0502-003 05/01/2017

HENDERSON, KNOX, MERCER, and WARREN COUNTIES

	Rates	Fringes
PAINTER		
Bridges.....	\$ 30.42	14.25
Brush and Roller.....	\$ 28.42	14.25
Spray, Structural Steel, & Sandblasting.....	\$ 28.92	14.25

PLAS0018-011 05/01/2017

FULTON (Northwestern Part), KNOX, MERCER (Southeastern Corner),
and WARREN COUNTIES

	Rates	Fringes
CEMENT MASON/CONCRETE FINISHER...	\$ 29.00	20.10

PLAS0018-012 06/01/2015

STARK COUNTY

	Rates	Fringes
CEMENT MASON/CONCRETE FINISHER...	\$ 36.70	22.08

PLAS0018-013 05/01/2017

FULTON (Except Northwest Part), PEORIA, and TAZEWELL COUNTIES

	Rates	Fringes
CEMENT MASON/CONCRETE FINISHER...	\$ 32.11	25.52

PLAS0018-028 05/01/2016

HANCOCK, HENDERSON (Southern half), and MCDONOUGH COUNTIES

	Rates	Fringes
CEMENT MASON/CONCRETE FINISHER...	\$ 28.64	24.57

PLAS0018-037 01/01/2019

HENDERSON (Northern Half) and MERCER (Except Southeastern
Corner) COUNTIES

	Rates	Fringes
CEMENT MASON/CONCRETE FINISHER...	\$ 27.90	23.16

TEAM0371-003 05/01/2017

MERCER COUNTY

	Rates	Fringes
TRUCK DRIVER		
Group 1.....	\$ 36.26	18.51
Group 2.....	\$ 36.77	18.51
Group 3.....	\$ 37.05	18.51
Group 4.....	\$ 37.36	18.51
Group 5.....	\$ 38.35	18.51

CLASSIFICATIONS:

GROUP 1: Drivers on 2 axles hauling less than 9 tons; air compressor & welding machines and brooms, including those pulled by separate units; Truck Driver Helper, warehouse employees; Mechanic Helpers; greasers and tiremen; pick-up trucks when hauling material, tools, or workers to and from and on the job site; and forklifts up to 6,000 lb capacity.

GROUP 2: 2 or 3 axles hauling more than 9 tons but hauling less than 16 tons; A-frame winch trucks; hydrolift trucks; Vector Trucks or similar equipment when used for transportation purposes; Forklift over 6,000 lb.capacity; winch trucks; and four axle combination units.

GROUP 3: 2, 3 or 4 Axles hauling 16 tons or more; 5-Axles or more combination units; drivers on water pulls; articulated dump trucks; mechanics and working forepersons.

GROUP 4: Low Boy and Oil Distributors.

GROUP 5: Drivers who require special protective clothing while employed on hazardous waste work.

TEAM0627-002 05/01/2017

FULTON, HANCOCK, HENDERSON, KNOX, MCDONOUGH, PEORIA, STARK, TAZEWELL, and WARREN COUNTIES

	Rates	Fringes
TRUCK DRIVER		
GROUP 1.....	\$ 36.15	18.30
GROUP 2.....	\$ 36.67	18.30
GROUP 3.....	\$ 36.91	18.30
GROUP 4.....	\$ 37.25	18.30
GROUP 5.....	\$ 38.23	18.30

CLASSIFICATIONS:

GROUP 1: Drivers on 2 axles hauling less than 9 tons; air compressor & welding machines and brooms, including those pulled by separate units; Truck Driver Helper, warehouse employees; Mechanic Helpers; greasers and tiremen; pick-up trucks when hauling material, tools, or workers to and from and on the job site; and forklifts up to 6,000 lb capacity.

GROUP 2: 2 or 3 axles hauling more than 9 tons but hauling less than 16 tons; A-frame winch trucks; hydrolift trucks; Vactor Trucks or similar equipment when used for transportation purposes; Forklift over 6,000 lb.capacity; winch trucks; and four axle combination units.

GROUP 3: 2, 3 or 4 Axles hauling 16 tons or more; 5-Axles or more combination units; drivers on water pulls; articulated dump trucks; mechanics and working forepersons.

GROUP 4: Low Boy and Oil Distributors.

GROUP 5: Drivers who require special protective clothing while employed on hazardous waste work.

WELDERS - Receive rate prescribed for craft performing operation to which welding is incidental.

=====

Note: Executive Order (EO) 13706, Establishing Paid Sick Leave for Federal Contractors applies to all contracts subject to the Davis-Bacon Act for which the contract is awarded (and any solicitation was issued) on or after January 1, 2017. If this contract is covered by the EO, the contractor must provide employees with 1 hour of paid sick leave for every 30 hours they work, up to 56 hours of paid sick leave each year. Employees must be permitted to use paid sick leave for their own illness, injury or other health-related needs, including preventive care; to assist a family member (or person who is like family to the employee) who is ill, injured, or has other health-related needs, including preventive care; or for reasons resulting from, or to assist a family member (or person who is like family to the employee) who is a victim of, domestic violence, sexual assault, or stalking. Additional information on contractor requirements and worker protections under the EO is available at www.dol.gov/whd/govcontracts.

Unlisted classifications needed for work not included within the scope of the classifications listed may be added after award only as provided in the labor standards contract clauses (29CFR 5.5 (a) (1) (ii)).

The body of each wage determination lists the classification and wage rates that have been found to be prevailing for the cited type(s) of construction in the area covered by the wage determination. The classifications are listed in alphabetical order of "identifiers" that indicate whether the particular rate is a union rate (current union negotiated rate for local), a survey rate (weighted average rate) or a union average rate (weighted union average rate).

Union Rate Identifiers

A four letter classification abbreviation identifier enclosed in dotted lines beginning with characters other than "SU" or "UAVG" denotes that the union classification and rate were prevailing for that classification in the survey. Example: PLUM0198-005 07/01/2014. PLUM is an abbreviation identifier of the union which prevailed in the survey for this classification, which in this example would be Plumbers. 0198 indicates the local union number or district council number where applicable, i.e., Plumbers Local 0198. The next number, 005 in the example, is an internal number used in processing the wage determination. 07/01/2014 is the effective date of the most current negotiated rate, which in this example is July 1, 2014.

Union prevailing wage rates are updated to reflect all rate changes in the collective bargaining agreement (CBA) governing this classification and rate.

Survey Rate Identifiers

Classifications listed under the "SU" identifier indicate that no one rate prevailed for this classification in the survey and the published rate is derived by computing a weighted average rate based on all the rates reported in the survey for that classification. As this weighted average rate includes all rates reported in the survey, it may include both union and non-union rates. Example: SULA2012-007 5/13/2014. SU indicates the rates are survey rates based on a weighted average calculation of rates and are not majority rates. LA indicates the State of Louisiana. 2012 is the year of survey on which these classifications and rates are based. The next number, 007 in the example, is an internal number used in producing the wage determination. 5/13/2014 indicates the survey completion date for the classifications and rates under that identifier.

Survey wage rates are not updated and remain in effect until a new survey is conducted.

Union Average Rate Identifiers

Classification(s) listed under the UAVG identifier indicate that no single majority rate prevailed for those classifications; however, 100% of the data reported for the classifications was union data. EXAMPLE: UAVG-OH-0010 08/29/2014. UAVG indicates that the rate is a weighted union average rate. OH indicates the state. The next number, 0010 in the example, is an internal number used in producing the wage determination. 08/29/2014 indicates the survey completion date for the classifications and rates under that identifier.

A UAVG rate will be updated once a year, usually in January of each year, to reflect a weighted average of the current negotiated/CBA rate of the union locals from which the rate is based.

WAGE DETERMINATION APPEALS PROCESS

1.) Has there been an initial decision in the matter? This can be:

- * an existing published wage determination
- * a survey underlying a wage determination
- * a Wage and Hour Division letter setting forth a position on a wage determination matter
- * a conformance (additional classification and rate) ruling

On survey related matters, initial contact, including requests for summaries of surveys, should be with the Wage and Hour Regional Office for the area in which the survey was conducted because those Regional Offices have responsibility for the Davis-Bacon survey program. If the response from this initial contact is not satisfactory, then the process described in 2.) and 3.) should be followed.

With regard to any other matter not yet ripe for the formal process described here, initial contact should be with the Branch of Construction Wage Determinations. Write to:

Branch of Construction Wage Determinations
Wage and Hour Division
U.S. Department of Labor
200 Constitution Avenue, N.W.
Washington, DC 20210

2.) If the answer to the question in 1.) is yes, then an interested party (those affected by the action) can request review and reconsideration from the Wage and Hour Administrator (See 29 CFR Part 1.8 and 29 CFR Part 7). Write to:

Wage and Hour Administrator
U.S. Department of Labor
200 Constitution Avenue, N.W.
Washington, DC 20210

The request should be accompanied by a full statement of the interested party's position and by any information (wage payment data, project description, area practice material, etc.) that the requestor considers relevant to the issue.

3.) If the decision of the Administrator is not favorable, an interested party may appeal directly to the Administrative Review Board (formerly the Wage Appeals Board). Write to:

Administrative Review Board
U.S. Department of Labor
200 Constitution Avenue, N.W.
Washington, DC 20210

4.) All decisions by the Administrative Review Board are final.

=====

END OF GENERAL DECISION"

SUBSTANCE ABUSE PREVENTION PROGRAM

Before the Contractor and any Subcontractor commences work, the Contractor and any Subcontractor shall have in place a written Substance Abuse Prevention Program for the prevention of substance abuse among its employees which meets or exceeds the requirements in P.A. 95-0635 or shall have a collective bargaining agreement in effect dealing with the subject matter of P.A. 95-0635.

The Contractor and any Subcontractor shall file with a public body: a copy of the substance abuse prevention program along with a cover letter certifying that their program meets the requirements of the Act, or a letter certifying that the Contractor or a Subcontractor has a collective bargaining agreement in effect dealing with the subject matter of the Act.

PROTECTION OF THE PUBLIC

In general, protection of the public shall be in accordance with Chapter 26, Article V of the Code of the City of Peoria, Illinois entitled "Excavation Generally," except that Sections 26-139, 26-140, 26-141 and 26-142 shall not apply.

Barricades, warning signs, and other devices shall be maintained as provided for by the City Code herein referred. The cost of any signs, barricades, or warning devices required to adequately accomplish partial or complete closure of streets shall be incidental to the item of work for which the traffic control is needed, and no additional compensation will be allowed.

ITEMS DESIGNATED FOR REMOVAL AND EXCAVATION

All removal items and excavated material remain the property of the Contractor unless otherwise indicated in the contract documents. The Contractor shall dispose of the removed items and/or excavated material outside the limits of the improvement as the Contractor may provide. Excavated material to remain on the job site shall be placed as directed by the Engineer.

CITY SIGNS

The contractor, at his own expense, shall be required, as directed by the Engineer, to relocate or remove and reinstall all street, traffic, parking, etc. signs belonging to the City within the limits of the improvement. All signs which interfere with construction operations shall be removed, stored in a place away from work, and replaced by the contractor after the improvement has been completed if they are not required for traffic control. Signs which are required for traffic control shall be reinstalled at a temporary location acceptable to the Engineer, in a workmanlike manner, visible to traffic, and maintained straight and neat for the duration of the temporary setting. Signs shall not be moved until progress of the work demands the relocation. The cost of this item shall be included in the contract unit price bid for the item of work which necessitated the removal.

BRICK REPAIRS

There will be NO brick sidewalk repairs conducted under this contract. There may be brick sidewalks replaced with concrete sidewalks. Where new concrete sidewalk will abut existing brick sidewalk the contractor will be responsible for making any necessary adjustments to the brick sidewalk to match the new concrete sidewalk. The City will provide any new brick required for the necessary adjustments. This work shall be considered incidental to the affected items of work and no additional compensation will be allowed.

TRAFFIC CONTROL & PROTECTION

Traffic control shall be in accordance with the applicable sections of the "Standard Specifications for Road and Bridge Construction," the applicable guidelines contained in the "Manual on Uniform Traffic Control Devices for Streets and Highways," these special provisions, and any special details and Highway standards contained herein and in the plans.

Special attention is called to Articles 107.09 and 107.14 of the "Standard Specifications for Road and Bridge Construction," applicable "Recurring Supplemental Specifications and Special Provisions" and the following Highway Standards relating to traffic control:

(701701-10; 701801-06; and 701901-08)

When construction operations require the closure of one lane, except turn lanes, the closure of said lane shall require the use of the specified arrow board per Standard 701901-08. The work shall be performed as directed by the Engineer.

Traffic movement should be inhibited as little as practical. Motorists should be guided in a clear and positive manner while approaching and traversing construction work areas. To ensure acceptable levels of operation, routine inspection of traffic control elements should be performed. The contractor will be required to inspect and initiate any needed maintenance to the traffic control devices on this contract. All traffic control devices shall be removed immediately when no longer needed. Construction equipment, materials and debris should be stored in such a manner as to not be vulnerable to vehicle impact, as directed by the Engineer.

The Contractor is expected to maintain a minimum of one lane open to traffic at all times for traffic. The roadway may be closed for short periods in order to offload materials. However, this operation must take place with proper traffic control signage and/or flagmen as noted in the traffic control standards contained herein. Roadway closures, regardless of duration must be coordinated with City of Peoria Police and Fire Departments. It is absolutely necessary that one lane of roadway can be used by fire, police, and other emergency vehicles at all times under all weather conditions.

The contractor shall, at all times, maintain a means for sidewalk traffic to detour the job. He shall also provide a minimum of interference to vehicular traffic and shall maintain barricades and warning signs as provided by the "Standard Specifications for Road and Bridge Construction."

The Contractor will be responsible for scheduling his operations to provide access to all businesses located along the improvement that have current access to the street. No less than one entrance to each commercial parking lot or building shall remain open at all times during construction.

The Contractor will be responsible with scheduling garbage pick up in the neighborhood along with notifying in writing no less than 3 calendar days before removing any part of existing alleys or driveways.

Non-Conformance: If the Contractor fails to comply with the above conditions, the Engineer may suspend the Contractor's work until the Contractor is in compliance with the above conditions.

TRAFFIC CONTROL AND PROTECTION will not be paid for separately, but shall be considered incidental to the affected items of work to be done.

DAMAGE TO EXISTING TREES

All necessary precautions shall be taken to prevent damage to existing trees. Roots of two inch (2") diameter or more shall not be severed. Precautions shall be taken to prevent damage to the bark of existing trees by machinery or other means. Any damage shall be corrected as directed by the Engineer at the expense of the Contractor.

VAULTS

After the wall of the structure has been blocked (at property owner expense) and the concrete floor broke; the vault shall either be filled with flowable fill within 2" of grade and leveled with CA-6 or filled completely with granular material as directed by engineer within 10" of grade and topped with 6" of CA-6. All costs will be paid for per Article 109.04.

SAWCUTTING

Sawcutting shall be required at all locations where new concrete meets existing concrete unless otherwise approved by the Engineer. This shall be considered incidental to the item of construction involved and no additional compensation will be allowed.

CONTACT PERSON

The City's designated Engineer will be responsible for this contract. Any questions you may have in reference to any portion of the bidding process can be directed to the Public Works Department, 309-303-8658. The City's Project Manager is Steve Letsky, PE, Civil Engineer.

EQUAL OPPORTUNITY REQUIREMENTS

EEO CONTRACT COMPLIANCE CLAUSE

It is hereby declared to be the public policy of the City of Peoria, that it will not execute a contract for goods and/or services with any individual, business enterprise, supplier/vendor; maintain a financial relationship with any financial institution; or use the services of any labor organization or member thereof found to be in violation of the provisions of the Municipal Code for the City of Peoria, Chapter 17, Article III, Division 4, Section 17-118.

This clause covers contractors, vendors, suppliers, borrowers and/or recipients of city resources, purchasers and/or developers of city owned property, and any other individuals or entities providing goods and/or services to the City of Peoria; and are hereinafter referred to as "Contractor."

If any Contractor conducting business with the City of Peoria fails to comply with the fair employment and affirmative action provisions of Chapter 17, Article III, Division 4 of the municipal code (hereinafter Chapter 17), the city, at its option, may do any or all of the following:

- (1) Cancel, terminate, or suspend the contract in whole or in part;
- (2) Declare the contractor ineligible for further contracts for one calendar year;
- (3) The Fair Employment and Housing Commission (hereinafter FEHC), in accordance with its rules and regulations, shall have the power to impose a penalty upon any Contractor failing to comply with Chapter 17 in an amount not less than \$50.00; nor more than as provided in Chapter 1, Section 1-5 of the municipal code, for each day that the Contractor fails to comply, upon a specific finding of such violation. The FEHC may order a Contractor found guilty of failure to comply with the provisions of Chapter 17 to pay all or a portion of the legal costs incurred by the city as a result of prosecution of such violations. Penalties assessed under the this clause may be recovered from the Contractor by setoff against unpaid portion of the contract price; and
- (4) Such other sanctions as may be imposed by the FEHC pursuant to the provisions of Chapter 17 and other applicable ordinance provisions of the municipal code.

During the performance of this contract, the Contractor agrees:

- (A) That it will not discriminate against any employee or applicant for employment because of race, color, religion, sex, sexual harassment, ancestry, national origin, place of birth, age, or a physical and/or mental disability which would not interfere with the efficient performance of the job in question. The contractor/vendor will take affirmative action to comply with the provisions of Peoria City Code, Chapter 17 and will require any subcontractor to submit to the City of Peoria a written commitment to comply with this division. The Contractor will distribute copies of this commitment to all persons who participate in recruitment, screening, referral, and selection of job applicants, prospective job applicants, members, or prospective contractors.

The Contractor agrees that the provisions of Chapter 17, of the Municipal Code of the City of Peoria is hereby incorporated by reference, as if set out verbatim

- (B) That it will examine each one of its workforce job classifications to determine if minorities and/or females are underutilized; and it will take appropriate affirmative action steps to rectify such identified underutilization.
- (C) That if it hires additional employees in order to perform this contract or any portion thereof, it will determine the availability of minority and females in the area(s) from which it may reasonably recruit; and every good faith effort will be made in its selection process to minimize or eliminate identified areas of minority and/or female underutilization for each job classification for which there are employment opportunities.

EEO Contract Compliance Clause

Page 2

- (D) That during the performance of this contract, the Contractor will maintain its eligibility status to conduct business with the City of Peoria under the provisions of the EEO certification registration program.
- (E) That in all solicitations or advertisements for employees placed by it or on its behalf, it will state that all applicants will be afforded equal opportunity without discrimination because of race, color, sex, religion, national origin, age, or physical and/or mental disability.
- (F) That it will send to each labor organization or representative of workers with which it has or is bound by a collective bargaining agreement or understanding, a notice advising such labor organization or representative of the Contractor's obligations under Chapter 17. If any such labor organization or representative fails or refuses to cooperate with the Contractor in its efforts to comply with Chapter 17, the Contractor will promptly so notify the Equal Opportunity Office (hereinafter EEO) and/or the FEHC for the City of Peoria.
- (G) That it will submit reports as required and furnish all relevant information as may from time to time be requested the EEO and/or the FEHC.
- (H) That it will permit access to all relevant books, records, accounts and work sites by EEO staff members for purposes of investigation to ascertain compliance with Chapter 17.
- (I) That it will include verbatim or by reference the provisions of Section 17-120 of Chapter 17 so that such provisions will be binding in the same manner as with other provisions of this contract. The Contractor will be liable for compliance with applicable provisions of this clause by all its subcontractors; and further, it will promptly notify the EEO and/or FEHC in the event any subcontractor fails or refuses to comply therewith. In addition, no Contractor will utilize any subcontractor declared by the EEO and/or FEHC to be non-responsive and therefore, ineligible for contracts or subcontracts with the City of Peoria.
- (J) That during the performance of this contract, the Contractor agrees: that it will have written sexual harassment policies that shall include, at a minimum, the following information: (i) the illegality of sexual harassment; (ii) the definition of sexual harassment under state law; (iii) a description of sexual harassment utilizing examples; (iv) the contractor's internal complaint process including penalties; (v) the legal recourse, investigative and complaint process available through the Illinois Department of Human Rights and the Human Rights Commission; (vi) directions on how to contact the Department of Human Rights and the Commission; and (vii) protection against retaliation as provided by Section 6-101 of this Act (Public Act 87-1257). A copy of the policies shall be provided to the Illinois Department of Human Rights or the City of Peoria upon request.
- (K) That during the performance of this contract, the Contractor agrees that they do not and will not maintain or provide for their employees, any segregated facilities at any of their establishments, or permit employees to perform their services at any location under their control where segregated facilities are maintained.

As used in this document, the term segregated facilities means any waiting rooms, work areas, rest rooms and wash rooms, and other storage or dressing areas, parking lots, drinking fountains, recreation or entertainment areas, transportation, housing facilities provided for employees which are segregated by explicit directive or are in fact segregated on the basis of race, religion, color, national origin, because of habit, local custom, or otherwise.

(Revised 01/04)



MINORITY AND WOMEN'S BUSINESS ENTERPRISE (M/WBE) PARTICIPATION

REQUIREMENTS FOR GOOD-FAITH EFFORTS (Projects exceeding \$50,000)

Description of Program

- A. It is the policy of the City of Peoria to encourage participation of M/WBE's on all city-funded construction projects. In complying with this clause bidders are required, when subcontracting opportunities are available, to make a good-faith effort to meet the goals established for M/WBE participation. The participation goals are cited in Section VI on the Subcontractor Utilization Statement.
- B. Failure to submit the documentation requested in Sections II and III of this document may cause (1) the bid to be rejected and determined non-responsive; (2) subject the bidders to the sanctions described in Section VIII.

Pre-Bid Efforts when Awarding Subcontracts

- A. Bidders are required to contact and solicit, in writing, bids from M/WBEs for available subcontracting. In seeking solicitations, bidders are to identify the portion(s) of work to be subcontracted and offer to break down any portion(s) of work into economically feasible units in order to facilitate M/WBE participation. Bidders also are to provide the name of a specific contact person in their notice to the M/WBEs. Contact shall be made prior to bid opening. The name of each company contacted, the date and method must be submitted with bid documents.

The low bidder shall provide to the City of Peoria, upon request, copies of faxes, letters, and e-mails sent to M/WBEs

- B. Bidders who are a MBE or WBE are not exempt from soliciting bids for available subcontracting. The bidder is required to contact, in writing, firms that will help the bidder meet the participation goal for the targeted group opposite to which the bidder belongs. If the bidder is identified as both a MBE and WBE, the participation goals shall be deemed to have been met.

In seeking solicitations, bidders are to identify the portion(s) of work

to be subcontracted and offer to break down any portion(s) of work into economically feasible units in order to facilitate M/WBE participation. Bidders also are to provide the name of a specific contact person in their notice to the M/WBEs. Contact shall be made prior to bid opening. A list containing the name of each company contacted, the date and method must be submitted with bid documents.

The low bidder shall provide to the City of Peoria, upon request, copies of faxes, letters, and e-mails sent to M/WBEs.

III. Good-Faith Efforts Documentation when Utilizing Subcontractors

- A. All Bidders must provide proof of its compliance with the pre-bid requirements and good-faith efforts to the City. Both the pre-bid documentation and the support documentation requested below must be submitted with bid documents.
 - 1. All Bidders must submit a properly completed “**Subcontractor Utilization Statement.**” All Bidders must provide the scope of work to be performed, the dollar amount to be paid, and the percentage amount of the contract for each company listed.
 - 2. All Bidders must submit a list of qualified M/WBE’s who submitted proposals but will not be utilized. This list must include a justification for not accepting the proposed bid.
- B. Disputes arising from the enforcement of these requirements will be resolved by the Equal Opportunity Office.

IV. Waiver Requirements When Self-Performing All Work

- A. All bidders will make every effort to make subcontract opportunities available to M/WBEs. However, if such an opportunity cannot be made available, the Bidder must seek a waiver by submitting “**M/WBE Participation Waiver Request.**” The waiver request must be submitted to the City of Peoria with bid documents.
- B. For the M/WBE waiver request to receive consideration, the following supportive documentation that applies must accompany the form:
 - 1. A narrative describing the Bidder’s good faith efforts to secure M/WBE participation prior to bid opening.
 - 2. A notarized affidavit attesting the Bidder did not receive inquiries or proposals from qualified M/WBEs in response to the required notification prior to bid opening.

3. A written explanation for why the Bidder believes no subcontracting opportunities exist. ***If the City of Peoria determines that the explanation is insufficient it reserves the right to halt the bid award process to request additional information from the Bidder. The Bidder will receive the request for information in writing.***
4. A written explanation for why the Bidder believes it is impracticable to award any subcontract(s) on the project in question. ***If the Equal Opportunity Office determines that the explanation is insufficient it reserves the right to halt the bid award process to request additional information from the Bidder. The Bidder will receive the request for information in writing.***

V. Change In Use of Subcontractors or Self-Performance Status

Before the General Contractor can deviate from utilizing any of the subcontractors listed on the Subcontractor Utilization Statement or its declared intent to self-perform, it must submit a completed **Notification of Change in Participation** form to the City of Peoria. Upon notification construction on the project may be delayed or halted until a review is conducted by the Equal Opportunity Office.

Regarding a self-performance change, if a subcontracting opportunity has been made available, the General Contractor must identify all good faith efforts made to meet the M/WBE participation goals, unless the change was due to an emergency.

VI. Procedures for Counting M/WBE Participation toward Goals (based upon Department of Transportation regulations)

- i. When an M/WBE participates in a contract, count only the value of the work actually performed by the M/WBE toward M/WBE participation goals.
 1. Count the entire amount of that portion of a construction contract (or other contract not covered by paragraph (i)(2) of this section) that is performed by the M/WBE's own forces. Include the cost of supplies and materials obtained by the M/WBE for the work of the contract including supplies purchased or equipment leased by the M/WBE (except supplies and equipment the M/WBE subcontractor purchases or leases from the prime contractor or its affiliate).
 2. Count the entire amount of fees or commissions performed by an M/WBE firm towards M/WBE goals if that firm provides the

Apparent Low Bidder a bona fide professional, technical, consultant, or managerial service or provides bonds or insurance specifically required in a City of Peoria contract.

3. If an M/WBE subcontracts a portion of its work to an M/WBE, 100% of the value of the subcontracted work may be counted toward the M/WBE goal, but any portion of the work the M/WBE subcontracts to a non-M/WBE does not count toward the M/WBE goal.
- ii. When an M/WBE participates in a joint venture on a City contract, only count the dollar value of the portion of the work that the M/WBE performs with its own forces toward M/WBE goals.
 - iii. Count expenditures to an M/WBE contractor toward M/WBE goals if, and only if, the M/WBE is performing a commercially useful function on that contract.
 1. An M/WBE performs a commercially useful function when it is responsible for performing, managing, and supervising its contracted work; moreover, with respect to materials and supplies used on the contract, it must also be responsible for negotiating its price, and purchasing and managing those supplies.
 2. An M/WBE does not perform a commercially useful function if its role is limited to that of an extra participant in a transaction, contract, or project through which funds are passed in order to obtain the appearance of M/WBE participation. It should be noted that an effort contrived to give the appearance of M/WBE participation is not considered a good faith effort and is considered an ethical violation that is subject to sanctions outlined in section V.
 3. If an M/WBE does not perform or exercise responsibility for at least 30% of the total cost of its contract with its own work force, you must presume that it is not performing a commercially useful function and the dollar amount of that work will not count toward the M/WBE goals.
 4. When an M/WBE is presumed the City of Peoria not to be performing a commercially useful function as provided in paragraph (iii)(3) of this section, the M/WBE may present evidence to rebut this presumption. Your rebuttal is subject to review by the City of Peoria.

- iv. Use the following factors in determining if an M/WBE trucking company is performing a commercially useful function:
 1. The M/WBE trucking company must manage and supervise the trucking work it is being paid to perform. A contrived arrangement for the purpose of giving the appearance of meeting M/WBE goals is not considered a good faith effort.
 2. The M/WBE trucking company must own and operate at least one fully licensed, insured, and operational truck used on the contract.
 3. The M/WBE trucking company receives credit for the total dollar value of the transportation services it provides on the contract using trucks it owns, insures, and operates.
 4. The M/WBE trucking company may lease trucks from another M/WBE trucking firm, including an owner-operator who is certified as an M/WBE. The M/WBE who leases trucks from another M/WBE receives total credit for the dollar value of the transportation services the M/WBE trucking lessee provides on the contract.
 5. The M/WBE trucking company may also lease trucks from a non-M/WBE trucking firm, including an owner-operator. The M/WBE who leases trucks from a non-M/WBE is only entitled to credit for the fee or commission it receives as a result of the lease arrangement. The M/WBE does not receive credit for the total dollar value of the transportation services provided by the lessee since these services are not provided by an M/WBE.
 6. A lease agreement with an M/WBE trucking firm must indicate that the M/WBE has exclusive use of and control over the truck. This does not preclude the leased truck from working for others during the term of the lease with the consent of the M/WBE, so long as the lease gives the M/WBE absolute priority for use of the leased truck. Leased trucks must display the name and identification number of the M/WBE.
- v. Count expenditures with M/WBEs for materials and supplies toward M/WBE goals in the following manner:
 1. If the materials or supplies are obtained from an M/WBE manufacturer, count 100% of the cost of the materials or supplies toward M/WBE goals.

Note: For purposes of this paragraph (v)(1), a manufacturer is a firm that operates or maintains a factory or establishment that produces, on the premises, the materials, supplies, articles, or equipment required under the contract and of the general character described by the specifications.

2. If the materials or supplies are purchased from an M/WBE regular dealer, count 60% of the cost of the materials or supplies toward M/WBE goals.

Note: For purposes of this section, a regular dealer is a firm that owns, operates or maintains a store, warehouse, or other establishment in which the materials, supplies, articles or equipment of the general character described by the specifications and required under the contract are brought, kept in stock, and regularly sold or leased to the public in the usual course of business.

(A) To be a regular dealer, the firm must be an established, regular business that engages, as its principal business and under its own name, in the purchase and sale or lease of the products in question.

(B) A person may be a regular dealer in such bulk items as petroleum products, steel, cement, gravel, stone, or asphalt without owning, operating, or maintaining a place of business as provided in this paragraph (v)(2), if the person both owns and operates distribution equipment for the products. Any supplementing of regular dealers' own distribution equipment shall be by a long-term lease agreement and not on an ad hoc or contract-by-contract basis.

(C) Packagers, brokers, manufacturers' representatives, or other persons who arrange or expedite transactions are not regular dealers within the meaning of the paragraph (v)(2).

3. If materials or supplies are purchased from an M/WBE which is neither a manufacturer nor a regular dealer, count only 5% of the contract amount toward the M/WBE goals.

VII. Record Keeping and Reporting

- A. The General Contractor and subcontractors agree to maintain records demonstrative of its good faith efforts to comply with the participation goals attached to the project. This would include, but not limited to, names of M/WBEs and non-minority firms awarded subcontracts, including dollar amount of the contract, payments to subcontractors, and weekly certified payroll reports. These records shall be made available to the City of Peoria.

- B. All information will be provided through ePrismSoft, an electronic web based compliance tracking software. Access to ePrismSoft has been furnished by the City of Peoria. To activate access, the General Contractor and subcontractors must contact Human Capital Development at webinfo@eprismsoft.com or 309/692-6400.

VIII. Sanctions

- A. The Equal Opportunity Office may recommend the rejection of the apparent low bid where the information submitted by the Apparent Low Bidder fails to objectively demonstrate compliance with the M/WBE Good-Faith Efforts requirements. The Apparent Low Bidder will be notified of this decision and the reasons in writing. The Apparent Low Bidder may request a hearing within five (5) business days of this notice. The request must be submitted to the Equal Opportunity Office. The hearing will be held no later than seven (7) business days after receipt of request. The City Manager or designee will conduct all hearings.
- B. Upon a finding that any party has not complied with the provisions of this clause, any one or a combination of the following actions may be taken:
 - 1. Declare the Apparent Low Bidder non-responsive and therefore ineligible for contract award.
 - 2. Declare the Apparent Low Bidder ineligible for further contracts for a calendar year.
 - 3. File a formal complaint against Apparent Low Bidder, and/or subcontractor with the Fair Employment and Housing Commission.

org. 05/08/08
rev. 04/17/12

HUMAN RIGHTS ACT

The contract will be subject to and governed by the rules and regulations of the Illinois Human Rights Act, including Public Act 87-1257 (effective July 1, 1993) which requires that every bidder shall have a written sexual harassment policy that includes, at a minimum, the following information:

- a. The illegality of sexual harassment;
- b. The definition of sexual harassment under State law;
- c. A description of sexual harassment, utilizing examples;
- d. The bidder's internal complaint process including penalties;
- e. The legal recourse, investigative and complaint process available through the Illinois Department of Human Rights and the Illinois Human Rights Commission;
- f. Directions on how to contact the Department and the Commission;
- g. Protection against retaliation as provided in the Act.

Bidders are hereby placed on notice, a copy of its policy shall be provided to the Department upon request.

SAXI-93
effective 7-1-93
per Legal Dept.

ROADWORK SPECIAL PROVISIONS

SALVAGING EXISTING MATERIAL

All existing municipally owned street castings, millings and pavement brick, in usable condition within the limits of the improvement shall, if not required for further use in the construction of the improvement, be carefully excavated and preserved by the Contractor. Sidewalk brick shall not be considered pavement brick and the contractor will have the salvage rights to the sidewalk brick removed. Said street castings, millings, and pavement brick shall be separated from other removal materials and hauled by the Contractor to the City's yard on Darst Street. The Contractor shall contact Sie Maroon at 309-645-5139, in advance of hauling salvaged materials to the City's yard on Darst Street.

The cost of salvaging and hauling existing municipally owned street castings, millings and pavement brick, as outlined herein, will not be paid for separately, but the cost shall be included in the contract unit price for the item of construction involved.

CONSTRUCTION DEBRIS

In accordance with Public Act 90-761, the following shall be added to the third paragraph of Article 202.03 of the "Standard Specifications for Road and Bridge Construction":

The Contractor shall not conduct any generation, transportation, or recycling of construction or demolition debris, clean or general or uncontaminated soil generated during construction, remodeling, repair, and demolition of utilities, structures, and roads that is not commingled with any waste, without the maintenance of documentation identifying the hauler, generator, place of origin of the debris or soil, the weight or volume of the debris or soil, and the location, owner, and operator of the facility where the debris or soil was transferred, disposed, recycled or treated. This documentation must be maintained by the Contractor for 3 years.

This documentation shall be included in applicable item of construction and shall not be paid for separately.

EROSION CONTROL

The Contractor shall install erosion control systems as necessary or as directed by the Engineer to prevent sediment from entering the City's storm drainage system or exiting the construction area. Erosion control systems shall be installed as necessary or as directed by the Engineer prior to stockpiling of material on the project site. The Contractor shall be responsible for the cost of cleanup and damages resulting from failure to comply with this provision. This work shall be considered incidental to the affected items of work and no additional compensation will be allowed.

The Contractor shall sweep and return to the work site any soil tracked onto the street by the end of the workday or before four (4) hours has elapsed, whichever is sooner. This work shall be considered incidental to the affected items of work and no additional compensation will be allowed.

EARTH EXCAVATION

This work shall be performed in accordance with the applicable sections of the Standard Specifications for Road and Bridge Construction except for the following:

Where topsoil placement is needed, the contractor shall provide and place material suitable for growing grass. The contractor may obtain this material from stockpiled excavation within the project limits or from outside the right-of-way with written property owner approval.

Existing brick sidewalks that are covered by soil and in the removal areas shall be removed and disposed of, paid for as EARTH EXCAVATION to a depth approved by the Engineer.

EARTH EXCAVATION has been provided in the contract quantities for the program to pay for removal of soil at locations where sidewalk does not currently exist. This work will be paid for at the contract unit price per CUBIC YARD for EARTH EXCAVATION; which shall include all labor, tools, and equipment necessary to complete this work as specified.

SIDEWALK REMOVAL

This work shall consist of the removal of all PCC sidewalk as directed by the Engineer. This work shall be done in accordance with Section 440 of the "Standard Specifications for Road and Bridge Construction." Payment for removal and replacement will not be allowed for items removed beyond the limits of construction or those items damaged needlessly by the contractor. The cost of sawing pavement where noted or directed by the engineer shall be incidental to the item of work.

This work will be paid for at the contract unit price per SQUARE FOOT for SIDEWALK REMOVAL; which shall include saw cutting, removing and disposing of said structure, all labor, tools, materials and equipment necessary to complete this work as specified.

SUBBASE GRANULAR MATERIAL

This item shall be in accordance with applicable portions of Section 311 of the "Standard Specifications for Road and Bridge Construction."

Locations where existing curb, combination curb & gutter, gutter flag, sidewalk, or combination curb & PCC sidewalk are being removed and replaced – this work shall consist of placing additional Subbase Granular Material, Type B as directed by the Engineer to prepare the sub-base to the proper elevation. This work shall be performed at the discretion of the Engineer. The thickness of aggregate required will vary. This work will be paid for at the contract unit price per TON for SUBBASE GRANULAR MATERIAL, TYPE B.

Locations where existing Brick Sidewalks are being removed and replaced with PCC sidewalks or where new curb, combination curb & gutter, gutter flag, sidewalk, or combination curb & sidewalk are being constructed for the first time - this work shall consist of providing a minimum of four inches (4") of Subbase Granular Material, Type B having a gradation of CA-6, compacted in place to provide the proper sub-base for curb, combination curb & gutter, gutter flag, sidewalk, and combination curb & sidewalk in accordance with the plans and as directed by the Engineer. This work will be paid for at the contract unit price per TON for SUBBASE GRANULAR MATERIAL, TYPE B.

All excavation required to prepare the sub-grade prior to placement of the granular material will not be paid for separately but included in the cost of the item the granular material is required for.

INLET ADJUSTMENT

This work shall be done in accordance with the applicable portions of Section 602 of the Standard Specifications and in the presence of the Engineer.

The Contractor shall be responsible for assuring that the castings are not damaged during removal. Castings damaged by the Contractor will be replaced at the Contractor's expense.

This work shall be paid for at the contract unit price per EACH for INLET ADJUSTMENT and shall include all labor, materials, tools, and equipment necessary to complete this work.

P.C.C. COMBINATION CURB AND SIDEWALK, 4"

This work shall consist of an integrally poured Portland cement concrete combination curb/sidewalk as in accordance with Section 424 of the "Standard Specifications for Road and Bridge Construction" and the IDOT Standard for Combination Concrete Curb & Sidewalk 4". This work shall also consist of an integrally poured Portland cement concrete side curb on the back or front side of side of the sidewalk.

The basis of payment shall be the area in square feet of the top surface of the curb and sidewalk for each property and will include the front finished face of curb, for that area exposed above the flowline.

This work will be paid for at the contract unit price per SQUARE FOOT for P.C.C. COMBINATION CURB AND SIDEWALK, 4" which shall include all labor, excavation, earth backfill along the back of sidewalk, materials, curing compound, tools and equipment necessary to complete this work as specified.

P.C.C. SIDEWALK, 4"

This work will be performed in accordance with Section 424 of the "Standard Specifications for Road and Bridge Construction" and City Standards.

The method of measurement shall be the total exposed surface area of the walk in square feet for each property.

This work will be paid for at the contract unit price bid per SQUARE FOOT for P.C.C. SIDEWALK, 4"., which shall include all labor, excavation, earth backfill along the sidewalk, seeding, curing compound, tools and equipment necessary to complete this work as specified.

CONCRETE STEP REMOVAL

This work shall consist of the removal of all P.C.C. Steps as directed by the Engineer. This work shall

be done in accordance with Section 440 of the "Standard Specifications for Road and Bridge Construction." Payment for removal and replacement will not be allowed for items removed beyond the limits of construction or those items damaged needlessly by the contractor. The cost of sawing pavement where noted or directed by the engineer shall be incidental to the item of work.

This work will be paid for at the contract unit price per SQUARE FOOT for CONCRETE STEP REMOVAL; which shall include saw cutting, removing and disposing of said structure, all labor, tools, materials and equipment necessary to complete this work as specified. The payment area shall be determined by adding the total height of the rise plus the total length of the run, and taking the sum times the width of the steps, all as indicated on the P.C.C. Step standard detail.

P.C.C. STEPS

This work shall be done in accordance with applicable portions of Section 423 of the "Standard Specifications for Road and Bridge Construction."

This work shall consist of construction steps at locations indicated by the engineer in accordance with the City Standard for P.C.C. Steps. The steps shall be constructed with IDOT Class SI Concrete as shown in Section 1020 of the "Standard Specifications for Road and Bridge Construction".

This work shall be paid for at the contract unit price per square foot determined by adding the total height of the rise plus the total length of the run, and taking the sum times the width of the steps, all as indicated on the P.C.C. Step standard detail.

This work shall be paid for at the contract unit price per SQ FOOT of P.C.C. STEPS which shall include all labor, excavation, earth backfill, granular material, materials including wire, curing compound, tools and equipment necessary to complete this work as specified. The cost will also include rubbing the face of the steps to create a clean finish.

INCIDENTAL HOT-MIX ASPHALT SURFACING (SPECIAL)

This item will be constructed in accordance with section 408 of the "Standard Specifications for Road and Bridge Construction", except that all necessary BITUMINOUS MATERIALS (PRIME COAT) and AGGREGATE (PRIME COAT) will be included in the cost of this item. The work will consist of sawing and milling a minimum of 3" in depth and one foot from the face of curb or outside edge of gutter flag, in the areas disturbed during removal, disposal of asphalt, grading and compacting base if necessary, applying the prime coat, and placing 3" of Hot-Mix Asphalt Surface Course. This work will also consist of placing concrete base course at the direction of the engineer if needed to fill the void between the new sidewalk and existing pavement. This work will not be paid for separately but included in the cost of the Incidental Hot-Mix Asphalt Surfacing (Special).

The work will be paid for at the contract unit price per SQ FT for INCIDENTAL HOT-MIX ASPHALT SURFACING (SPECIAL), which shall include all saw cutting, removal, prime coats, concrete base course, excavation, labor, tools, materials and equipment necessary to complete the work as specified.

WALL REMOVAL

Work includes removing existing timber and concrete retaining walls to the satisfaction of the

Engineer. This work shall be measured for payment in linear length of wall to be removed for the whole, existing structure. For example, existing wood wall at 20 feet long and 2 courses high will be measured along the exposed linear, horizontal length, 20 feet as payable.

Earthen excavation behind the existing wall shall not be measured or paid for separately but shall be incidental to the WALL REMOVAL pay item.

The work will be paid for at the contract unit price per FOOT for WALL REMOVAL, which shall include all saw cutting, removal, excavation, labor, tools, materials and equipment necessary to complete the work as specified.

TIMBER RETAINING WALL

Work includes furnishing and installing timber retaining walls to the satisfaction of the Engineer in accordance with Section 507 of the Standard Specifications for Road and Bridge Construction.

Timber & Galvanized Spikes Specifications

The timbers shall be pressure treated, according to Article 1007 of the Standard Specification for Road and Bridge Construction. Minimum thickness shall be 6". If the wall is greater than 3.5' high, consult a Structural or Geotechnical Engineer. The spike shall be of sufficient length to secure timbers together.

Timber tiebacks shall be placed at 8'O.C. and shall be a minimum of 4' long spiked to the wall.

Permeable backfill shall be placed behind the wall. One timber shall below finished grade on a compacted and level sub base.

Spikes shall be galvanized in accordance with the applicable sections of Article 1000 of the Standard Specifications. The spikes shall be of sufficient length to secure timbers together.

Backfill and Drainage Specifications

Backfill material to consist of open graded aggregate 1" nominal size. The backfill should be placed to within 4" from the top of wall to the bottom of the subgrade. Backfill shall be placed in accordance with the requirements of Article 502.10.

P.C.C. Sidewalk, 4" will be placed adjacent to the wall and backfill material.

2" Weep hole spacing between timbers shall be placed at sidewalk finished grade.

All equipment and labor required to perform this work will be paid for at the unit price per SQUARE FOOT of TIMBER RETAINING WALL.

CURING COMPOUND

This item shall be furnished and applied in accordance with Article 1020.13 of the "Standard Specifications" except as herein provided.

Curing Compound shall be applied to all exposed Portland Cement Concrete Surfaces.

*This work will **not** be paid for separately but shall be included in the cost of the item of the construction bid.*

CONCRETE FIBERS

The contractor may use micro-fibers in lieu of the welded wire mesh. The micro-fibers and dosage rate shall be approved by the engineer prior to use. The dosage rate shall meet the recommendations of the supplier. The micro-fibers shall be supplied by an IDOT approved supplier of synthetic fibers.

Micro fiber shall be used in all PCC Driveway Pavement 6" and 8" pours. Dosage rate shall be no less than 1 pound per cubic yard of PCC mix.

Concrete fibers will not be paid for separately but shall be included in the cost of the concrete item.

SEEDING AND MULCHING

This work shall consist of broadcasting Class I (Lawn Mixture) seed over all earthen areas disturbed by construction in accordance with Article 250 of the Standard Specifications. All seeded areas shall immediately be mulched using Method 1 in accordance with Article 251 of the Standard Specifications.

Seeding and Mulching will **not** be paid for separately, but shall be considered incidental to the construction contract.

SIDEWALK RAMPS FOR THE DISABLED

Sidewalk ramps shall be constructed per ADA and PROWAG requirements. Details of ramps are per Highway Standard 424001-07, 424006-01, 424011-01, 424016-02, 424021-01, 424026-01, and 424031-01. Any variation in the shape of curbs and sidewalk or needed landscaping of dirt at a corner to accommodate ramps for the handicapped shall not be paid for separately, but shall be considered incidental to the item of construction involved.

This work will be paid for at the contract unit price per SQUARE FOOT of P.C.C. COMBINATION CURB & SIDEWALK, 4" or P.C.C. SIDEWALK 4."

Any side curb poured integrally with a ramp will be paid for at the contract unit price per SQUARE FOOT OF P.C.C. COMBINATION CURB & SIDEWALK 4". The square footage will include the exposed vertical surface areas of the side curbs.

Concrete Curb, Type B & Combination Concrete Curb & Gutter along the roadway will be paid for at the contract unit price per FOOT. Detectable warnings will be paid for at the contract unit price per SQUARE FOOT. There shall be a minimum of four inches of concrete placed below the detectable

warning panels.

DETECTABLE WARNINGS

This work shall consist of a 24-inch strip of the Federal Standard color 22144, brick red, as its standard of detectable warning in the direction of travel and shall extend the full width of the curb ramp or flush surface. This work shall conform to the details given in the plans and in accordance with Section 424 of the "Standard Specifications for Road and Bridge Construction".

Detectable warnings shall be installed at all designated ADA ramps per the appropriate IDOT curb ramp standard.

The following will be the acceptable construction techniques.

1. Cast-in-Place truncated dome ramps must be formed with a rigid mold. Every area of the tool shall be tamped directly above the stamp to form a uniform appearance. The concrete used shall be Class X (SI) concrete that has the Federal Standard color 22144, brick red, the entire depth. Broadcasting brick red dye or painting the sidewalk brick red **will not** be acceptable methods.
2. DetecTile PFC Composite truncated dome panels. Panels must be the Federal Standard color 22144, brick red. Panels shall be placed within the Class X (SI) concrete. They shall have a minimum of four anchors per ceramic panel to secure the panels to the concrete ramp.
3. Armor-Tile Tactile Systems manufactured Diamond-Hard Vitrified Polymer truncated panels. Panels must be the Federal standard color 22144, brick red, unless otherwise approved by the Engineer.
4. Pre-Cast concrete truncated dome ramp panels. The panels shall be a minimum of 2-inches thick with the entire depth consisting of Class X (SI) concrete that is Federal Standard color 22144, brick red. The pre-cast panels shall have wire mesh or fiber mesh reinforcement. Tapered edges or holes so that dowel reinforcement rod can be placed within the insert shall be acceptable methods. These shall be placed before placing the rest of the ramp so that they are tightly secured into place.
5. TufTile Polymer detectable warning surfaces. Panels must be the Federal standard color 22144, brick red, unless otherwise approved by the Engineer.

Final determination of acceptability shall be the responsibility of the Engineer.

THESE FIVE METHODS ARE THE ONLY ACCEPTABLE MEANS FOR TRUNCATED DOME RAMPS WITHIN THE CITY OF PEORIA.

Detectable Warnings will be paid for at the contract unit price per square foot of surfacing, which shall include all labor, tools, materials and equipment necessary to complete the work as specified.

TIE BARS & DOWEL BARS

All tie bars required for sidewalk, curb, or pavement will not be paid for separately but included in the cost of the item the tie bars are required for. Any dowel bars required will not be paid for separately but included in the cost of the item required for.

APPENDIX A

EEO DOCUMENTS



OFFICE OF EQUAL OPPURTUNITY

READ THESE INSTRUCTIONS BEFORE FILLING OUT THE EMPLOYER REPORT CC-1

Who needs to file? Any business providing a good or service for remuneration to the City of Peoria, the County of Peoria, or the Greater Peoria Sanitary District and any business receiving financial assistance from the City of Peoria.

What needs to be submitted? A completed Employer Report Form CC-1 to obtain for the first time, or renew an EEO Certification Number.

First Time Applicant: Complete the form. Check the appropriate box to indicate "initial registration" status. Supply a copy of your company's Sexual Harassment Policy (for specific instructions on the sexual harassment policy, see the Sexual Harassment Policy Information Sheet).

Renewal Applicant: Complete the form. Check the appropriate box to indicate "renewal registration" status. If known, enter expired or expiring EEO Certification Number in space provided. **You do not need to submit the Sexual Harassment Policy as it is already on file.**

Processing Fee: A fifty-dollar (\$50.00) processing fee will be charged with each submission of the Employer Report Form CC-1

Method of Processing Fee Payment: The City of Peoria Treasurer's office will accept checks (payable to the City of Peoria) money order, cash payment, OR online thru Illinois E-Pay.

Submittal Instructions: Either mail, hand deliver, or email (eeo@peoriagov.org) your completed materials.

Business Address:

City of Peoria
Office of Equal Opportunity
419 Fulton Street, Room 403
Peoria, IL 61602-1276

Online Payment:

Visit www.illinoisepay.com

Workforce Profile Definitions

Definition of employee - For purposes of this form, an "employee" is an individual performing services for remuneration for the employer. Only full-time employees are to be reported.

Description of Race/Ethnic - Race/ethnic designations as used by the Department do not denote scientific definitions of anthropological origins. For the purposes of this report, an employee may be included in the group to which he or she appears to belong, identifies with, or is regarded in the community as belonging. However, no person should be counted in more than one race/ethnic group. They are:

"White (Not of Hispanic Origin)" All persons having origins in any of the original peoples of Europe, North Africa, or the Middle East.

"Black or African-American" (Not of Hispanic Origin). All persons having origins in any of the Black racial groups of Africa. "

"Hispanic or Latino" All persons of Mexican, Puerto Rican, Cuban, Central or South American, or other Spanish culture or origin, regardless of race.

“Asian or Pacific Islander” All persons having origins in any of the original peoples of the Far East, Southeast Asia, the Indian Subcontinent, or the Pacific Islands. This area includes, for example, China, India, Japan, Korea, the Philippine Islands, and Samoa.

“American Indian or Alaskan Native” All persons having origins in any of the original peoples of North America, and who maintain

Definition of categories - Each employee should be counted in only one job category. Select the category containing the jobs most similar to that performed by the employee. The jobs listed in each category are intended to provide examples, not a complete list, of all job titles falling into that category.

“Officials and Managers” Occupations requiring administrative and managerial personnel who set broad policies, exercise overall responsibility for execution of these policies, and direct individual departments or special phases of a firm's operations. Includes: officials, executives, middle management, plant managers, etc.

“Professionals” Occupations requiring either college graduation or experience of such kind and amount as to provide a comparable background. Includes: accountants and auditors, airplane pilots and navigators, architects, artists, scientists, designers, dietitians, editors, engineers, lawyers, librarians, mathematicians, registered professional nurses, etc.

“Technicians” Occupations requiring a combination of basic scientific knowledge and manual skill which can be obtained through 2 years of post high school education, such as is offered in many technical institutes and union colleges, or through equivalent on-the-job training. Includes: computer programmers, drafters, engineering/mathematical/scientific aides, licensed/practical/vocational nurses, photographers, radio operators, etc.

“Sales” Occupations engaging wholly or primarily in direct selling. Includes: advertising agents and sales workers, insurance agents and brokers, real estate agents and brokers, stock and bond sales workers, demonstrators, sales workers and sales clerks, grocery clerks, and cashiers/checkers, etc.

“Office and Clerical” Includes all clerical-type work regardless of level of difficulty, where the activities are predominantly non-manual though some manual work not directly involved with altering or transporting the products is included. Includes: bookkeepers, collectors (bills and accounts), messengers and office helpers, office machine operators (including computer), shipping and receiving clerks, stenographers, typists and secretaries, telegraph and telephone operators, etc.

“Craft Workers (skilled)” Manual workers of relatively high skill level having a thorough and comprehensive knowledge of the processes involved in their work. Exercise considerable independent judgment and usually receive an extensive period of training. Includes: the building trades, hourly paid supervisors/lead operators not members of management, mechanics, skilled machinists, electricians, compositors/typesetters/engravers, etc.

“Operatives (semiskilled)” Workers who operate machine or processing equipment or perform other factory-type duties of intermediate skill level which can be mastered in a few weeks and require only limited training. Includes: apprentices (auto/plumbing/bricklaying/carpentry/electrical/machinist/mechanical/building trade/metalworking/printing trades, etc.)

“Laborers (unskilled)” Workers in manual occupations which generally require no special training who perform elementary duties that may be learned in a few days and require the application of little or no independent judgment. Includes: garage laborers, car washers/greasers, gardeners, farm workers, stevedores, wood choppers, lifting/digging/mixing/loading/pulling laborers, etc.

“Service Workers” Workers in both protective and non-protective service occupations. Includes: attendants (hospital/other institutions, professional/personal service, nurses aides/orderlies), barbers, char workers/cleaners, cooks, counter/fountain workers, elevator operators, firefighters/fire protection, guards, doorkeepers, stewards, janitors, etc.

If you have any questions, call the Equal Opportunity Office at (309) 494-8530

KEEP THESE INSTRUCTIONS FOR YOUR RECORDS

Rev.: Feb. 2014

SECTION VI. WORKFORCE INFORMATION (FULL TIME ONLY)

SEE THE INSTRUCTIONS BEFORE COMPLETING THIS SECTION.

JOB CATEGORIES	OVERALL TOTALS		WHITE (Not of Hispanic Origin)		BLACK OR AFRICAN AMERICAN		HISPANIC OR LATINO		ASIAN OR PACIFIC ISLANDER		AMERICAN INDIAN OR ALASKAN NATIVE	
	M	F	M	F	M	F	M	F	M	F	M	F
Office & Managers												
Professionals												
Technicians												
Sales Workers												
Office & Clerical												
Craft Workers (Skilled)												
Operatives (Semi-Skilled)												
Laborers (Unskilled)												
Service Workers												
TOTAL												

M= MALE F=FEMALE

SECTION VII. GENERAL INFORMATION

1. DESCRIBE THE GOODS OR SERVICES PROVIDED BY THE EMPLOYER.		
	YES	NO
2. IS IT THE COMPANY'S POLICY TO RECRUIT, HIRE, TRAIN, UPGRADE, PROMOTE, AND DISCIPLINE PERSONS WITHOUT REGARD TO RACE, COLOR, SEX, RELIGION, NATIONAL ORIGIN, VETERAN STATUS, AGE, MENTAL AND/OR PHYSICAL DISABILITY?		
3. HAS THE COMPANY DEVELOPED A WRITTEN AFFIRMATIVE ACTION PLAN?		
4. HAS THE COMPANY DEVELOPED A WRITTEN SEXUAL HARASSMENT POLICY STATEMENT? ATTACH A COPY IF THIS IS THE FIRST TIME APPLYING FOR AN EEO CERTIFICATION NUMBER.		
5. HAS THE COMPANY NOTIFIED ITS ADVERTISING AND RECRUITMENT SOURCES THAT IT IS AN EQUAL OPPORTUNITY EMPLOYER?		
6. HAS THE COMPANY BEEN CERTIFIED AS A MINORITY, WOMAN OR DISADVANTAGED BUSINESS ENTERPRISE BY A STATE OR FEDERAL AGENCY? CHECK STATUS ___ MBE ___ WBE ___ DBE ATTACH COPY IF NOT PREVIOUSLY SUBMITTED.		
7. DOES THE CONTRACTOR UNDERSTAND AND AGREE THAT IT IS ILLEGAL TO MAINTAIN SEGREGATED FACILITIES FOR ANY OF ITS EMPLOYEES ON THE BASIS OF RACE, RELIGION, COLOR, NATIONAL?		
8. HAS THE COMPANY EVER BEEN DISQUALIFIED FROM CONDUCTING BUSINESS WITH A LOCAL, STATE, OR FEDERAL AGENCY? IF SO, PLEASE PROVIDE DATES AND THE REASONS FOR DISQUALIFICATION		

SECTION VIII. CERTIFICATION

I certify that the information provided in this report, and in any attachments thereto, is true and accurate to the best of my knowledge and belief. The employer filing this report agrees that all applicable ordinances and administrative policies, procedures regulating affirmative action and equal employment opportunity are hereby incorporated by the individual authorized to sign this form on behalf of the employer.

SIGNATURE	PRINT NAME & TITLE	TELEPHONE NUMBER	DATE
-----------	--------------------	------------------	------

MINORITY AND WOMEN BUSINESS ENTERPRISE DIRECTORY

To assist Bidders in their outreach efforts, the City of Peoria has developed a Minority and Women Business Enterprise (M/WBE) directory. Go to the City's website at <http://www.peoriagov.org/equal-opportunity/minority-and-women-business-enterprise-mwbe-directory/> to view the directory.

EQUAL EMPLOYMENT OPPORTUNITY

To be awarded a contract all Suppliers, Vendors and Contractors to the City of Peoria must be registered in the City of Peoria's Contract Compliance Program and have a current EEO Certification Number. This program is unrelated to any State or Federal program. To obtain or renew a number, an Employer Report Form CC-1, a copy of your company's sexual harassment policy statement, if a first time applicant and a Fifty-dollar (\$50.00) processing fee must be submitted to the City of Peoria. Go to the City's website at <http://www.peoriagov.org/equal-opportunity/> to obtain the form and instructions page.

Note: Suppliers, Vendors and Contractors do not need an EEO Certification Number to submit a bid proposal. However, it is required prior to the award of the contract.

MINORITY AND FEMALE WORKFORCE UTILIZATION

The City of Peoria is committed to ensuring our construction projects offer equal employment opportunity to all the citizens we serve. The Prime Contractor and all of its subcontractors are to make a good faith effort to comply with the following goals for minority and female workforce utilization.

1. Eighteen (18) percent of the total hours worked, per trade, should be performed by minority workers.
2. Three (3) percent of the total hours worked, per trade, should be performed by female workers.

Each contractor must maintain certified payroll records verifying the hours worked by minority and female workers. These records must be provided to the City of Peoria. For directions on submitting this information, see Minority and Women's Business Enterprise (M/WBE) Participation Requirements for Good-Faith Efforts, Section VII.

CONTRACT DELIVERABLES

CITY OF PEORIA SUBCONTRACTOR PAYMENT FORM

PRIME CONTRACTOR

Name: _____

Address: _____

Phone: _____

Contact Person: _____

PROJECT

Name:

Pay Estimate No:

Percent Complete: _____ %

Work Period: _____ to

INSTRUCTIONS: Complete the table below. If additional space is needed attach extra pages as needed and included all information listed in the table below; along with project name and prime contractor.

Subcontractor (Name)	Payment Amount	Payment Type (F-full/ P-partial)
	\$	
	\$	
	\$	
	\$	
	\$	
	\$	
Total Payment Amount for Work Completed	\$	

This form is to verify the work completed and the amount paid to a subcontractor utilized on the above listed project. Under penalty of law for perjury or falsification, the undersigned certifies that the payment reported herein was made to the subcontractors listed.

Signature of Prime Contractor

Date

CITY OF PEORIA MONTHLY WORKFORCE ANALYSIS

Check appropriate status

Month Ending _____

Contractor

Subcontractor

Name: _____

Address: _____

Contact Person: _____

Phone: _____

Project: _____

Date Work Started: _____

Percent Complete: _____ %

Job Categories	Number of Employees				Hours of Employment									
	Total # of Employees		Total Minorities		African American		Asian/Pacific Islander		American Indian/Alaskan Native		Hispanic		White	
	M	F	M	F	M	F	M	F	M	F	M	F	M	F
Foremen														
Electricians														
Glaziers														
Iron Workers														
Laborers														
Teamsters														
Millwrights														
Pipe Fitters														
Plumbers														
Plasterers														
Painters														
Roofers														
Operating Engs														
Tile Layers														
Sheet Metal Wkrs														
TOTALS														

Instructions: The total number of hours worked on the project (Hours of Employment), and the total number of individuals working on the project during the reporting period (Number of Employees) should be submitted on this form to the Project Resident Engineer every month. Each contractor and subcontractor should submit with this form certified payroll records for the period covered. The prime contractor is responsible for securing and submitting with his/her report, reports from all subcontractors.

**CITY OF PEORIA
NOTIFICATION OF CHANGE IN PARTICIPATION**

Type of Change _____

Date: _____

_____ Subcontractor. Complete Part 1
_____ Self-Performance. Complete Part 2

PRIME CONTRACTOR

PROJECT

Name: _____
Address: _____
Phone: _____

Name: _____

PART 1

If changing from previously identified subcontractor to another, complete both From and To.

From Name _____

To Name _____

Address _____

Address _____

Phone _____

Phone _____

Status _____ MBE _____ WBE _____ Non-M/WBE

Status _____ MBE _____ WBE _____ Non-M/WBE

Contract Amount _____

Will scope of work change? _____ Yes _____ No

Describe change

Reason for Contractor Change

PART 2

Complete if deviating from intent to self-perform.

Prime Contractor will have to hire another contractor to perform work. _____ Yes _____ No

Change was due to _____ Emergency _____ Non-Emergency

Explain Situation _____

Describe good faith efforts to utilize M/WBE

Name of added Contractor _____

Address _____

Phone _____

Status _____ MBE _____ WBE _____ Non-M/WBE Contract Amount _____

Scope of Work

Signed: _____

Contractor

Title

MISCELLANEOUS

CITY OF PEORIA
SAMPLE CONTRACT

This agreement, made and entered into this _____ day of _____, 2019, by and between the City of Peoria, an Illinois Municipal Corporation, Party of The First Part, and _____, Party of The Second Part for the improvement known as the _____;

WITNESSETH: That for and in consideration of the payments and agreements mentioned in the proposal hereto attached, to be made and performed by the Party of the First Part, and according to the terms expressed in the bond referring to these presents, the Party of The Second Part agrees with said Party of The First Part, at his/their own proper cost and expense to furnish and deliver all the work, materials and supplies in accordance with the specifications contained in said proposal, and in full compliance with all the terms of this agreement, for the amount of _____ (\$_____).

IT IS UNDERSTOOD AND AGREED that the instructions to bidders, proposal, bid, specifications, performance bond and maintenance bond are component parts of this contract and shall be deemed a part hereof. It is also understood and agreed that the contractor shall not assign, transfer, convey or otherwise dispose of this contract, or his right to execute it, or his right, title or interest in or to it or any part thereof, unless the previous written consent of the City Manager of the City of Peoria shall first be obtained thereto.

EMPLOYEE/EMPLOYMENT RESTRICTIONS – THE CONTRACTOR:

THE CONTRACTOR (hereinafter referred to as "SERVICE PROVIDER") agrees, as a condition of accepting this contract with the City of Peoria, that, for a period of one (1) year following completion of this contract, it shall be prohibited from hiring, directly or indirectly, any City employee or official who was involved, directly or indirectly in: (1) the selection and/or recommendation to select the SERVICE PROVIDER for performance of this contract; (2) coordinating the efforts of the SERVICE PROVIDER in the consummation or completion of this contract; or (3) monitoring or determining the performance of the SERVICE PROVIDER. The SERVICE PROVIDER further acknowledges and agrees that, upon the City's determination that a violation of this provision has occurred, the penalty imposed, at the sole discretion of the City, may include one or more of the following: (1) cancellation of any other contract(s) between the City of Peoria and the SERVICE PROVIDER; (2) disqualification of the SERVICE PROVIDER from bidding or being awarded future contracts with the City of Peoria for a period of two [2] years; and/or (3) payment of liquidated damages to the City of Peoria in the amount of TWENTY FIVE THOUSAND DOLLARS (\$25,000.00).

IN WITNESS WHEREOF, the said parties have executed these presents on the date above mentioned.

THE CITY OF PEORIA

BY: _____
City Manager

ATTEST: _____
City Clerk

EXAMINED AND APPROVED:

Corporation Counsel

PARTY OF THE SECOND PART

(name of individual, firm, or corporation)

BY: _____
(member of firm or officer of corporation)

(If a Co-Partnership)

(seal)
(seal)

Partners doing business under the firm name
of _____ (seal)
(Party of the second part)
(If an Individual)

(seal)

(Party of the second part)

**COMMUNITY
DEVELOPMENT BLOCK
GRANT
(CDBG) DOCUMENTS**

CDBG BID INFORMATION

I. General Compliance

The contractor agrees to comply with the requirements of Title 24 of the Code of Federal Regulations, Part 570 (the Housing and Urban Development regulations concerning Community Development Block Grants (CDBG)). The contractor also agrees to comply with any other applicable Federal, State and local laws, regulations and policies governing the funds provided to be awarded under this bid.

II. Administrative Requirements

A. Audits and Inspections

All contractor records with respect to any matters covered by this bid proposal shall be made available to the City, their designee, or the Federal Government, at any time during normal business hours, as often as the City deems necessary, to audit, examine, and make excerpts or transcripts of all relevant data. Any deficiencies noted in audit reports must be fully cleared by the contractor within 30 days after receipt of notification. Failure of the contractor to comply with the above audit requirements will constitute a violation of any awarded contract and may result in the withholding of future payments.

III. Personnel & Participant Conditions

A. Civil Rights

1. Compliance

The contractor agrees to comply with Title VI of the Civil Rights Act of 1964 as amended, Title VIII of the Civil Rights Act of 1968 as amended, Section 104(b) and Section 109 of Title I of the Housing and Community Development Act of 1974 as amended, Section 504 of the Rehabilitation Act of 1973, the Americans with Disabilities Act of 1990, the Age Discrimination Act of 1975, Executive Order 11063, and Executive Order 11246 as amended by Executive Orders 11375 and 12086.

2. Nondiscrimination

The contractor will not discriminate against any employee or applicant for employment because of race, color, creed, religion, ancestry, national origin, sex, disability or other handicap, age, marital/familial status, or status with regard to public assistance. The contractor will take affirmative action to insure that all employment practices are free from such discrimination. Such employment practices include but are not limited to the following: hiring, upgrading, demotion, transfer, recruitment or recruitment advertising, layoff, termination, rates of pay or other forms of compensation, and selection for training, including apprenticeship. The contractor agrees to post in conspicuous places, available to employees and applicants for employment, notices to be provided by the contracting agency setting forth the provisions of this nondiscrimination clause.

3. Section 504

The contractor agrees to comply with any Federal regulations issued pursuant to compliance with Section 504 of the Rehabilitation Act of 1973 (29 USC 706), which prohibits discrimination against the handicapped in any Federally assisted program.

B. Affirmative Action

1. Women/Minority Business Enterprises

The contractor will use its best efforts to afford minority and women owned business enterprises, to the maximum extent practicable, the opportunity to participate in the performance of the scope of work outlined in the bid and corresponding awarded contract. The term "minority and female business enterprise" means a business with at least 51% owned and controlled by minority group members or women. The contractor may rely on written representations by businesses regarding their status as minority and female business enterprises in lieu of an independent investigation.

The prime contractor agrees to take all necessary affirmative steps to assure that:

- Small and minority firms, and women's business enterprises are on subcontractor solicitation lists.
- Small and minority firms, and women's business enterprises are subcontractor solicited whenever they are potential sources.
- That total requirements and delivery schedules are divided into smaller tasks, when economically feasible, to permit maximum participation by small and minority firms, and women's business enterprises.
- The services of the Small Business Administration and Minority Business Development Agency are used.

2. Access to Records

The contractor shall furnish and cause each of its own subcontractors to furnish all information and reports required hereunder and will permit access to its books, records and accounts by the City, HUD or its agent, or other authorized Federal officials for purposes of investigation to ascertain compliance with the rules, regulations and provisions stated herein.

3. Notifications

The contractor will send to each labor union or representative of workers with which it has a collective bargaining agreement or other contract or understanding, a notice advising the labor union or worker's representative of the contractor's commitments hereunder, and shall post copies of the notice in conspicuous places available to employees and applicants for employment.

4. Subcontract Provisions

The contractor will include the civil rights and affirmative action provisions in every subcontract or purchase order, specifically or by reference, so that such provisions will be binding upon each of its own subcontractors.

5. Use of Debarred, Suspended or Ineligible Contractors or Subcontractor

The contractor shall not, either directly or indirectly, employ, award contracts to, or other engage the services of or fund any contractor or subcontractor who is in a period of debarment, suspension, or placement in ineligible status under the provision of 24 CFR part 24.

C. Employment Restrictions

1. Prohibited Activity

The contractor is prohibited from using funds provided herein or personnel employed in the work of the project for: political activities; sectarian or religious activities; lobbying, political patronage, and nepotism activities.

2. Labor Standards

The contractor agrees to comply with the requirements of the Secretary of Labor in accordance with the Davis-Bacon Act as amended, the provisions of Contract Work Hours and Safety Standards Act, the Copeland "Anti-Kickback" Act (40 USC 276a-276a-5; 40 USC 327 and 40 USC 276c) and all other applicable Federal, State and local laws and regulations pertaining to labor standards insofar as those acts apply to the performance of this contract. The contractor shall maintain documentation which demonstrates compliance with hour and wage requirements of this part. Such documentation shall be made available to the City to review upon request.

The contractor agrees that all subcontractors engaged under contracts in excess of \$2,000.00 for construction, renovation or repair work financed in whole or in part with assistance under this contract, shall comply with Federal requirements adopted by the City pertaining to such contracts and with the applicable requirements of the regulations of the Department of Labor, under 29 CFR Parts 1, 3, 5 and 7 governing the payment of wages and ratio of apprentices and trainees to journey workers; provided, that if the wage rates higher than those required under the regulations are imposed by state or local law, nothing hereunder is intended to relieve the contractor of its obligation, if any, to require payment of the higher wage. The contractor shall cause or require to be inserted in full, in all such contracts subject to such regulations, provisions meeting the requirements of this paragraph.

Additional information regarding Davis-Bacon Wage requirements and certified payroll forms can be found on the United States Department of Labor website:
(<http://www.dol.gov/whd/govcontracts/dbra.htm>)

3. Section 3 Clause

1. Compliance

Compliance with the provisions of Section 3, the regulations set forth in 24 CFR 135, and all applicable rules and orders issued hereunder prior to the execution of this contract, shall be a condition of the Federal financial assistance provided under this contract and binding upon the City, the contractor and any of the contractor's subcontractors. Failure to fulfill these requirements shall subject the City, the contractor and any of the contractor's subcontractors, their successors and assigns, to those sanctions specified by the Agreement through which Federal assistance is provided. The contractor certifies and agrees that no contractual or other disability exists which would prevent compliance with these requirements.

The contractor further agrees to comply with these Section 3 requirements and to include the following language in all subcontracts executed under this Agreement: "The work to be performed under this contract is a project assisted under a program providing direct Federal financial assistance from HUD and is subject to the requirements of Section 3 of the Housing and Urban Development Act of 1968, as amended, 12 USC 1701. Section 3 requires that "to the greatest extent feasible opportunities for training and employment be given to low-income residents of the project area and contracts for work in connection with the project be awarded to business concerns that provide economic opportunities for low-income persons residing in the City of Peoria."

The contractor further agrees to ensure that opportunities for training and employment arising in connection with a public construction project are given to low income person residing within the City of Peoria where the CDBG-funded project is located.

The contractor certifies and agrees that no contractual or other legal incapacity exists which would prevent compliance with these requirements.

2. Notifications

The contractor agrees to send to each labor organization or representative of workers with which it has a collective bargaining agreement or other contract of understanding, if any, a notice advising said labor organization or worker's representative of its commitments under this Section 3 clause and shall post copies of the notice in conspicuous places available to employees and applicants for employment or training.

3. Subcontracts

The contractor will include this Section 3 clause in every subcontract and will take appropriate action pursuant to the subcontract upon a finding that the subcontractor is in violation of regulations issues by the City. The contractor will not subcontract with any entity where it has notice or knowledge that the latter has been found in violation of regulations under 24 CFR 135 and will not let any subcontract unless the entity has first provided it with preliminary statement of ability to comply with the requirements of these regulations.

D. Conduct

1. Subcontracts

a. Approvals

The contractor shall not enter into any subcontracts with any agency or individual in the performance of this contract without the written consent of the City prior to the execution of such agreement.

b. Content

The contractor shall cause all of the provisions of this contract in its entirety to be included in and made a part of any subcontract executed in the performance of this Agreement.

c. Selection Process

The contractor shall undertake to insure that all subcontracts let in the performance of this Agreement shall be awarded on a fair and competitive basis. Executed copies of all subcontracts shall be forwarded to the City along with documentation concerning the selection process.

2. Hatch Act

The contractor agrees that no funds provided, nor personnel employed under this contract, shall be in any way or to any extent engaged in the conduct of political activities in violation of Chapter 15 of Title V United States Code.

3. Conflict of Interest

The contractor agrees to abide by the provisions of 24 CFR 570.611 with respect to conflicts of interest, and covenants that it presently has no financial interest and shall not acquire any financial interest, direct or indirect, which would conflict in any manner or degree with the performance of services required under this Agreement.

The contractor further covenants that in the performance of this Agreement no person having such a financial interest shall be employed or retained by the contractor hereunder. These conflict of interest provisions apply to any person who is an employee, agent, consultant, officer, or elected official or appointed official of the City, or of any designated public agencies or contractors which are receiving funds under the CDBG Entitlement program.

4. Lobbying

The contractor shall certify that:

- a. No Federal appropriated funds have been paid or will be paid, by or on behalf of it, to any person for influencing or attempting to influence an officer or employee of any agency, a Member of Congress, an officer or employee of Congress, or an employee of a Member of Congress in connection with the awarding of any Federal contract, the making of any Federal grant, the making of any Federal loan, the entering into of any cooperative agreement, and the extension, continuation, renewal, amendment, or modification of any Federal contract, grant, loan, or cooperative agreement.
- b. If any funds other than Federal appropriated funds have been paid or will be paid to any person for influencing or attempting to influence an officer or employee of any agency, a Member of Congress, an officer or employee of Congress, or an employee of a Member of Congress in connection with this Federal contract, grant, loan, or cooperative agreement, it

- will complete and submit Standard Form- LLL, "Disclosure Form to Report Lobbying," in accordance with its instructions.
- c. It will require that the language of paragraph (d) of this certification be included in the award documents for all subawards at all tiers (including subcontractors) and that all subcontractors shall certify and disclose accordingly; and
 - d. Lobbying Certification - Paragraph d
 - a. This certification is a material representation of fact upon which reliance was placed when this transaction was made or entered into. Submission of this certification is a prerequisite for making or entering into this transaction imposed by section 1352, title 31, U.S. Code. Any person who fails to file the required certification shall be subject to a civil penalty of not less than \$10,000 and not more than \$100,000 for each such failure.

5. Religious Organization

The contractor agrees that funds provided under this contract will not be utilized for religious activities, to promote religious interests, or for the benefit of a religious organization in accordance with the Federal regulations specified in 24 CFR 570.200(j).

CERTIFICATION REGARDING LOBBYING

The undersigned certifies, to the best of his or her knowledge and belief, that:

- (1) No Federal appropriated funds have been paid or will be paid, by or on behalf of the undersigned, to any person for influencing or attempting to influence an officer or employee of an agency, a Member of Congress, an officer or employee of a Member of Congress in connection with the awarding of any Federal contract, the making of any Federal grant, the making of any Federal loan, the entering into of any cooperative agreement, and the extension, continuation, renewal, amendment, or modification of any Federal contract, grant, loan, or cooperative agreement.
- (2) If any funds other than Federal appropriated funds have been paid or will be paid to any person for influencing or attempting to influence an officer or employee of any agency, a member of Congress, an officer or employee of Congress, or an employee of a Member of Congress in connection with this Federal contract, grant, loan, or cooperative agreement, the undersigned shall complete and submit Standard Form-LLL, "Disclosure Form to Report Lobbying," in accordance with its instruction.
- (3) The undersigned shall require that the language of this certification be included in the award documents for all subawards at all tiers (including subcontracts, subgrants and contracts under grants, loans, and cooperative agreements) and that all subrecipients shall certify and disclose accordingly.

This certification is a material representation of fact upon which reliance was placed when this transaction was made or entered into. Submission of this certification is a prerequisite for making or entering into this transaction imposed by Section 1352, Title 31, U.S. Code. Any person who fails to file the required certification shall be subject to a civil penalty of not less than \$10,000 and not more than \$100,000 for each such failure.

C&G Concrete Construction Co, Inc 1906 Meadow Ave East Peoria, IL 61611

Contractor Organization



Signature of Certifying Official

7-23-2019

Date

NON-COLLUSION AFFIDAVIT OF PRIME BIDDER

STATE OF ILLINOIS,)
) SS
COUNTY OF TAZEWELL)

Rodney Slusher being first duly sworn, deposes and says that:

- (1) He/She is Vice President of the party (a partner or officer of the firm, etc.) has submitted the attached Bid;
- (2) He/She is fully informed respecting the preparation and contents of the attached Bid and of all pertinent circumstances respecting such Bid;
- (3) Such Bid is genuine and is not a collusive or sham Bid;
- (4) Neither the said Bidder nor any of its officers, partners, owners, agents, representatives, employees or parties in interest, including this affidavit, has in any way colluded, conspired, connived or agreed, directly or indirectly with any other Bidder, firm or person to submit a collusive or sham Bid in connection with the Contract for which the attached Bid has been submitted or to refrain from bidding in connection with such Contract, or has in any manner, directly or indirectly, sought by agreement or collusion or communication or conference with any other Bidder, firm or person to fix the price or prices in the attached Bid or of any other Bidder, or to fix any overhead, profit or cost element of the Bid price of the Bide price of any other Bidder, or to secure through any collusion, conspiracy, connivance or unlawful agreement any advantage against the City of Peoria or any person interested in the proposed Contract; and
- (5) The price or prices quoted in the attached Bid are fair and proper and are not tainted by any collusion, conspiracy, connivance or unlawful agreement on the part of the Bidder or any of its agents, representatives, owners, employees, or parties in interest, including this affiant.

(Signed) *Rodney Slusher*

I, the undersigned, a Notary Public in and for said County, in the State aforesaid, DO HEREBY CERTIFY that Rodney Slusher, personally know to me to be the same person whose name is subscribed to the foregoing instrument, appeared before me this day in person, and acknowledged that he/she/they signed, sealed, and delivered the said instrument as a free and voluntary act, for the uses and purposes therein set forth.

GIVEN under my hand and notarial seal, this 23rd day of July 2019.
Patricia A Slusher
Notary Public



CERTIFICATION OF BIDDER REGARDING EQUAL EMPLOYMENT OPPORTUNITY

Instructions

This certification is required pursuant to Executive Order 11246 (30 F.R. 12319-25). The implementing rules and regulations provide that any bidder or prospective contractor, or any of their proposed subcontractors, shall state as an initial part of the bid or negotiations of the contract whether it has participated in any previous contract or subcontract subject to the equal opportunity clause, and if so, whether it has filed all compliance reports due under applicable instructions.

Where the certification indicates that the bidder has not filed a compliance report due under applicable instructions, such bidder shall be required to submit a compliance report within seven (7) calendar days after bid opening. No contract shall be awarded unless such report is submitted.

Certification by Bidder

Name and Address of Bidder (include zip code)

C&G Concrete Construction Co, Inc 1906 Meadow Ave East Peoria, IL 61611

1. Bidder has participated in a previous contract or subcontract subject to the Equal Opportunity Clause.

Yes X No _____

2. Compliance reports were required to be filed in connection with such contract or subcontract.

Yes X No _____

3. Have you ever been or are you being considered for sanction due to violation of Executive Order 11246, as amended?

Yes _____ No X

Patricia Slusher

Name and Title of Signer (print or type)

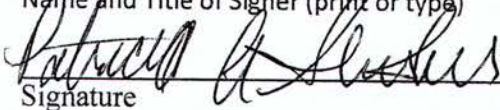

Signature

7-23-2019

Date

**CERTIFICATION OF BIDDER REGARDING
SECTION 3 AND SEGREGATED FACILITIES**

C&G Concrete Construction Co, Inc.

Name of Prime Contractor

Harrison Impact Zone

Project Name

The undersigned hereby certifies that:

- a. Section 3 provisions are included in the Contract.
- b. A written Section 3 plan was prepared and submitted as part of the bid proceedings (if bid equals or exceeds \$10,000).
- c. No segregated facilities will be maintained.

Patricia Slusher

Name and Title of Signer (print or type)

Signature

7/23/19
Date

CONTRACTOR SECTION 3 PLAN FORMAT

(if bids equals or exceeds \$10,000)

C&G Concrete Construction Co. (Name of Contractor) agrees to implement the following specific affirmative action steps directed at increasing the utilization of lower income residents and businesses within the City/County of Peoria.

- A. To ascertain from the locality's CDBG program official the exact boundaries of the Section 3 covered project area and where advantageous, seek the assistance of local officials in preparing and implementing the affirmative action plan.
- B. To attempt to recruit from within the city/county the necessary number of lower income residents through: Local advertising media, signs placed at the proposed site for the project, and community organizations and public or private institutions operating within or serving the project area such as Service Employment and Redevelopment (SER), Opportunities Industrialization Center (OIC), Urban League, Concentrated Employment Program, Hometown Plan, or the U.S. Employment Service.
- C. To maintain a list of all lower income residents who have applied either on their own or on referral from any source, and to employ such persons, if otherwise eligible and if a vacancy exists.
- *D. To insert this Section 3 plan in all bid documents, and to require all bidders on subcontracts to submit a Section 3 affirmative action plan including utilization goals and the specific steps planned to accomplish these goals. **Loan, grants contracts and subsidies for less than \$10,000 will be exempt*
- *E. To insure that subcontracts which are typically let on a negotiated rather than a bid basis in areas other than Section 3 covered project areas, are also let on a negotiated basis, whenever feasible, when let in a Section 3 covered project area. **Loan, grants contracts and subsidies for less than \$10,000 will be exempt*
- F. To formally contact unions, subcontractors and trade associations to secure their cooperation for this program.
- G. To insure that all appropriate project area business concerns are notified of pending sub-contractual opportunities.
- H. To maintain records, including copies of correspondence, memoranda, etc., which document that all of the above affirmative action steps have been taken.
- I. To appoint or recruit an executive official of the company or agency as Equal Opportunity Officer to coordinate the implementation of this Section 3 plan.
- J. To list on **Table A**, information related to subcontracts to be awarded.
- K. To list on **Table B**, all projected workforce needs for all phases of this project by occupation, trade, skill level and number of positions.

As officers and representatives of C&G Concrete Construction Co, Inc. (Name of Contractor) We the undersigned have read and fully agree to this Affirmative Action Plan, and become a party to the full implementation of this program.

Patricia A. Slusher
Signature

PRESIDENT

Title

7-23-2019

Date

Rodney Slusher
Signature

VICE PRESIDENT

Title

7-23-2019

Date

PROPOSED SUBCONTRACTS BREAKDOWN TABLE A

FOR THE PERIOD COVERING _____, 2019 THROUGH _____, 20____
(Duration of the CDBG-Assisted Project)

COLUMN 1	COLUMN 2	COLUMN 3	COLUMN 4	COLUMN 5
TYPE OF CONTRACT (BUSINESS OF PROFESSION)	TOTAL NUMBER OF CONTRACTS	ESTIMATED NUMBER TOTAL APPROXIMATE DOLLAR AMOUNT	CONTRACTS TO PROJECT AREA BUSINESSES	ESTIMATED DOLLAR AMOUNT TO PROJECT AREA BUSINESSES
	NA		NA	
	NA			

*The Project Area is coextensive with the City of Peoria's boundaries.

Company

Signature of Certifying Official

Date

CONTRACTOR SECTION 3 PLAN FORMAT (continued)

ESTIMATED PROJECT WORKFORCE BREAKDOWN TABLE B

Job Category	Total Estimate Positions	No. Positions by Permanent Employees	No. Positions NOT Currently Occupied	No. Positions to be Filled with L.I.P.A.R*
Officers/Supervisors	1	1		
Professionals	1	1		
Technicians				
Management				
Office Clerical	1	1		
Service Workers				
Others				
TRADE POSITIONS:				
Journeyman	10	10		
Helpers				
Apprentices	1	1		
Max. No. Trainees				
Others				
TRADE POSITIONS:				
Journeyman				
Helpers				
Apprentices				
Max. No. Trainees				
Others				
TRADE POSITIONS:				
Journeyman				
Helpers				
Apprentices				
Max. No. Trainees				
Others				
TOTALS:	14	14	0	0

*L.I.P.A.R. = Lower Income Project Area Residents. Individuals residing within the City/County of Peoria whose family income does not exceed 80% of the area median income of Peoria County.

C&G Concrete Construction Co, Inc.
 COMPANY NAME

DAVIS BACON ACT ACKNOWLEDGEMENT

The undersigned will be performing work for the City of Peoria. The work will be paid for with funds from the City's CDBG program. The undersigned has been informed that any work paid for entirely or in part with CDBG funds requires compliance with the Davis-Bacon Act, 40USC Section 276a et seq., (the "Act").

The undersigned hereby agrees to comply with the Act and will ensure that all subcontractors performing work shall also comply with all provisions of the Act.

The undersigned hereby acknowledges that the Act, inter alia, requires that he/she and his/her subcontractors pay workers employed directly upon the site of the work no less than the locally prevailing wages and fringe benefits paid on projects of a similar character. Such local prevailing wage rates will be determined by the U.S. Department of Labor.

By execution of this acknowledgment, the undersigned acknowledges that he/she and all subcontractors and suppliers will comply with all requirements of the Act. Additionally, the undersigned shall hold harmless from and indemnify the City of Peoria, its subrecipients and their respective officials, officers, employees, agents, and representatives against all claims, suits, actions, costs, counsel fees, expenses, damages, judgments or decrees, by reason by the undersign's failure or the failure of any subcontractor, suppliers, or any other person employed by the undersigned to comply with the requirements of the Act.

C&G Concrete Construction Co, Inc.
(print or type name of business)

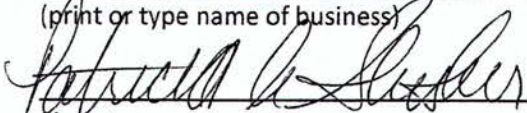
Signature

PRESIDENT
Title

7-23-2019
Date

DAVIS BACON ACT ACKNOWLEDGEMENT

The undersigned will be performing work for the City of Peoria. The work will be paid for with funds from the City's CDBG program. The undersigned has been informed that any work paid for entirely or in part with CDBG funds requires compliance with the Davis-Bacon Act, 40USC Section 276a et seq., (the "Act").

The undersigned hereby agrees to comply with the Act and will ensure that all subcontractors performing work shall also comply with all provisions of the Act.

The undersigned hereby acknowledges that the Act, inter alia, requires that he/she and his/her subcontractors pay workers employed directly upon the site of the work no less than the locally prevailing wages and fringe benefits paid on projects of a similar character. Such local prevailing wage rates will be determined by the U.S. Department of Labor.

By execution of this acknowledgment, the undersigned acknowledges that he/she and all subcontractors and suppliers will comply with all requirements of the Act. Additionally, the undersigned shall hold harmless from and indemnify the City of Peoria, its subrecipients and their respective officials, officers, employees, agents, and representatives against all claims, suits, actions, costs, counsel fees, expenses, damages, judgments or decrees, by reason by the undersign's failure or the failure of any subcontractor, suppliers, or any other person employed by the undersigned to comply with the requirements of the Act.

(print or type name of business)

Signature

Title

Date

See previous

FEDERAL LABOR STANDARDS PROVISIONS

U.S. Department of Housing and Urban Development (HUD)

Applicability

The Project or Program to which the construction work covered by this bid is being assisted by the United States of America and the following Federal Labor Standards Provisions are included in this Contract pursuant to the provisions applicable to such Federal assistance.

1. (i) Minimum Wages. All laborers and mechanics employed or working upon the site of the work (or under the United States Housing Act of 1937 or under the Housing Act of 1949 in the construction or development of the project), will be paid unconditionally and not less often than once a week, and without subsequent deduction or rebate on any account (except such payroll deductions as are permitted by regulations issued by the Secretary of Labor under the Copeland Act(29 CFR Part 3), the full amount of wages and bona fide fringe benefits (or cash equivalents thereof) due at time of payment computed at rates not less than those contained in the wage determination of the Secretary of Labor which is attached hereto and made a part hereof, regardless of any contractual relationship which may be alleged to exist between the contractor and such laborers and mechanics. Contributions made or costs reasonably anticipated for bona fide fringe benefits under Section 1(b) (2) of the Davis-Bacon Act on behalf of laborers or mechanics are considered wages paid to such laborers or mechanics, subject to the provisions of 29 CFR 5.5(a) (1) (iv); also, regular contributions made or costs incurred for more than a weekly period (but not less often than quarterly) under plans, funds, or programs, which cover the particular weekly period, are deemed to be constructively made or incurred during such weekly period.

Such laborers and mechanics shall be paid the appropriate wage rate and fringe benefits on the wage determination for the classification of work actually performed, without regard to skill, except as provided in 29 CFR Part 5.5(a) (4). Laborers or mechanics performing work in more than one classification may be compensated at the rate specified for each classification for the time actually worked therein: Provided that the employer's payroll records accurately set forth the time spent in each classification in which work is performed. The wage determination (including any additional classification and wage rates conformed under 29 CFR Part 5.5(a) (1) (ii) and the Davis-Bacon poster (WH-1321) shall be posted at all times by the contractor and its subcontractors at the site of the work in a prominent and accessible place where it can be easily seen by the workers.

(ii) (a) Any class of laborers or mechanics which is not listed in the wage determination and which is to be employed under the contract shall be classified in conformance with the wage determination. HUD shall approve an additional classification and wage rate and fringe benefits therefore only when the following criteria have been met.

(1) The work to be performed by the classification requested is not performed by a classification in the wage determination; and

(2) The classification is utilized in the area by the construction industry; and

(3) The proposed wage rate, including any bona fide fringe benefits, bears a reasonable relationship to the wage rates contained in the wage determination.

(4) As a prerequisite for approval of a helper classification, the helper classification must prevail in the area where the work is performed.

If the contractor and the laborers and mechanics to be employed in the classification (if known), or their representatives, and HUD or its designee agree on the classification and wage rate (including the amount designated for fringe benefits where appropriate), a report of the action taken shall be sent by HUD or its designee to the Administration of the Wage and Hour Division, Employment Standards Administration, U.S. Department of Labor, Washington, D.C. 20210. The Administrator, or an authorized representative, will approve, modify, or disapprove every additional classification action within 30 days of receipt and so advise HUD or its designee or will notify HUD or its designee within the 30-day period that additional time is necessary. (Approved by the Office of Management and Budget under OMB control number 1215-0140.)

(c) In the event the contractor, the laborers or mechanics to be employed in the classification or their representatives, and HUD or its designee do not agree on the proposed classification and wage rate (including the amount designated for fringe benefits, where appropriate), HUD or its designee shall refer the questions, including the views of all interested parties and the recommendation of HUD or its designee, to the Administrator for determination. The Administrator, or an authorized representative will issue a determination within 30 days of receipt and so advise HUD or its designee or will notify HUD or its designee within the 30-day period that additional time is necessary.

(Approved by the Office of Management and Budget under OMB Control Number 1215-0140.)

(d) The wage rate (including fringe benefits where appropriate) determined pursuant to subparagraphs (1) (b) or (c) of this paragraph, shall be paid to all workers performing work in the classification under this contract from the first day on which work is performed in the classification.

(iii) Whenever the minimum wage rate prescribed in the contract for a class of laborers or mechanics includes a fringe benefit which is not expressed as an hourly rate, the contractor shall either pay the benefit as stated in the wage determination or shall pay another bona fide fringe benefit or an hourly case equivalent thereof.

(iv) If the contractor does not make payments to a trustee or other third person, the contractor may consider as part of the wages of any laborer or mechanic the amount of any costs reasonably anticipated in providing bona fide fringe benefits under a plan or program, provided, that the Secretary of Labor has found, upon the written request of the contractor, that the applicable standards of the Davis-Bacon Act have been met. The Secretary of Labor may require the contractor to set aside in a separate account assets for the meeting of obligations under the plan or program. (Approved by the Office of Management and Budget under OMB Control Number 1215-0140.)

2. Withholding. HUD or its designee shall upon its own action or upon written request of an authorized representative of the Department of Labor withhold or cause to be withheld from the contractor under this contract or any other Federal contract with the same prime contractor, or any other Federally-assisted contract subject to Davis-Bacon prevailing wage requirements, which is held by the same prime contractor so much of the accrued payments or advances as may be considered necessary to pay laborers and mechanics, including apprentices, trainees and helpers, employed by the contractor or any subcontractor the full amount of wages required by the contract. In the event of failure to pay any laborer or mechanic, including any apprentice, trainee or helper, employed or working on the site of the work (or under the United States Housing Act of 1937 or under the Housing Act of 1949 in the construction or development of the project), all or part of the wages required by the contract, (HUD or its designee may, after written notice to the contractor, sponsor, applicant, or owner, take such action as may be necessary to cause the suspension of any further payment, advance, or guarantee of funds until such violations have ceased. HUD or its designee may, after written notice to the contractor, disburse such amounts withheld for and on account of the contractor or subcontractor to the respective employees to whom they are due. The Comptroller General shall make such disbursements in the case of direct Davis—Bacon Act contracts.

3. (i) Payrolls and basic records. Payrolls and basic records relating thereto shall be maintained by the contractor during the course of the work preserved for a period of three years thereafter for all laborers and mechanics working at the site of the work (or under the United States Housing Act of 1937, or under the Housing Act of 1949, in the construction or development of the project). Such records shall contain the name, address, and social security number of each such worker, his or her correct classification, hourly rates or wages paid (including rates of contributions or costs anticipated for bona fide fringe benefits or cash equivalents thereof of the types described in Section 1(b)(2)(B) of the Davis-Bacon Act), daily and weekly number of hours worked, deductions made and actual wages paid. Whenever the Secretary of Labor has found under 29 CFR 5.5(1) (1) (iv) that the wages of any laborer or mechanic include the amount of any costs reasonably anticipated in providing benefits under a plan or program described in Section 1 (b) (2) (B) of the Davis-Bacon Act, the contractor shall maintain records which show that the commitment to provide such benefits is enforceable, that the plan or program is financially responsible, and that the plan or program has been communicated in writing to the laborers or mechanics affected, and records which show the costs anticipated or the actual cost incurred in providing such benefits. Contractors employing apprentices or trainees under approved programs shall maintain written evidence of the registration of apprenticeship programs and certification of trainee programs, the registration of the apprentices and trainees, and the ratios and wage rates prescribed in the applicable programs. (Approved by the Office of Management and Budget under OMB Control Numbers 1215-0140 and 1215-0017.)

(ii) (a) The contractor shall submit weekly for each week in which any contract work is performed a copy of all payrolls to HUD or its designee if the agency is a party to the contract, but if the agency is not such a party, the contractor will submit the payrolls to the applicant,

sponsor, or owner, as the case may be, for transmission to HUD or its designee. The payrolls submitted shall set out accurately and completely all of the information required to be maintained under 29 CFR Part 5.5(a) (3) (i). This information may be submitted in any form desired. Optional Form WH-347 is available for this purpose and may be purchased from the Superintendent of Documents (Federal Stock Number 029-005-00014-1), U.S. Government Printing Office, Washington, D.C. 20402. The prime contractor is responsible for the submission of copies of payrolls by all subcontractors. (Approved by the Office of Management and Budget under OMB Control Number 1215-0149).

(b) Each payroll submitted shall be accompanied by a "Statement of Compliance," signed by the contractor or subcontractor or his or her agent who pays or supervises the payment of the persons employed under the contract and shall certify the following:

(1) That the payroll for the payroll period contains the information required to be maintained under 29 CFR Part 5.5(a) (3) (i) and that such information is correct and complete;

(2) That each laborer or mechanic (including each helper, apprentice, and trainee) employed on the contract during the payroll period has been paid the full weekly wages earned, without rebate, either directly or indirectly, and that no deductions have been made either directly or indirectly from the full wages earned, other than permissible deductions as set forth in 29 CFR Part 3;

(3) That each laborer or mechanic has been paid not less than the applicable wage rates and fringe benefits or cash equivalents for the classification of work performed, as specified in the applicable wage determination incorporated into the contract.

(c) The weekly submission of a properly executed certification set forth on the reverse side of Optional Form WH-347 shall satisfy the requirement for submission of the "Statement of Compliance" required by paragraph A.3.(ii)(b) of this section.

(d) The falsification of any of the above certifications may subject the contractor or subcontractor to civil or criminal prosecution under Section 1001 of Title 18 and Section 231 of Title 31 of the United States Code.

(iii) The contractor or subcontractor shall make the records required under paragraph A.3. (i) of this section available for inspection, copying, or transcription by authorized representatives of HUD or its designee or the Department of Labor, and shall permit such representatives to interview employees during working hours on the job. If the contractor or subcontractor fails to submit the required records or to make them available, HUD or its designee may, after written notice to the contractor, sponsor, applicant, or owner, take such action as may be necessary to cause the suspension of any further payment, advance, or guarantee of funds. Furthermore, failure to submit the required records upon request or to make such records available may be grounds for debarment action pursuant to 29 CFR Page 5.12.

4. (i) Apprentices and Trainees. Apprentices will be permitted to work at less than the predetermined rate for the work they performed when they are employed pursuant to and individually registered in a bona fide apprenticeship program registered with the U.S. Department of Labor, Employment and Training Administration, Bureau of Apprenticeship and

Training, or with a State Apprenticeship Agency recognized by the Bureau, or if a person is employed in his or her first 90 days of probationary employment as an apprentice in such an apprenticeship program, who is not individually registered in the program, but who has been certified by the Bureau of Apprenticeship and Training or a State Apprenticeship Agency (where appropriate) to be eligible for probationary employment as an apprentice. The allowable ratio of apprentices to journeymen on the job site in any craft classification shall not be greater than the ratio permitted to the contractor as to the entire work force under the registered program. Any worker listed on a payroll at an apprentice wage rate, who is not registered or otherwise employed as stated above, shall be paid not less than the applicable wage rate on the wage determination for the classification of work actually performed. In addition, any apprentice performing work on the job site in excess of the ratio permitted under the registered program shall be paid not less than the applicable wage rate on the wage determination for the work actually performed. Where a contractor is performing construction on a project in a locality other than that in which its program is registered, the ratios and wage rates (expressed in percentages of the journeyman's hourly rate) specified in the contractor's or subcontractor's registered program shall be observed. Every apprentice must be paid at not less than the rate specified in the registered program for the apprentice's level of progress, expressed as a percentage of the journeymen hourly rate specified in the applicable wage determination. Apprentices shall be paid fringe benefits in accordance with the provisions of the apprenticeship program. If the apprenticeship program does not specify fringe benefits, apprentices must be paid the full amount of fringe benefits listed on the wage determination for the applicable classification. If the Administrator determines that a different practice prevails for the applicable apprentice classification, fringes shall be paid in accordance with that determination. In the event the Bureau of Apprenticeship and Training, or a State Apprenticeship Agency recognized by the Bureau, withdraws approval of an apprenticeship program, the contractor will no longer be permitted to utilize apprentices at less than the applicable predetermined rate for the work performed until an acceptable program is approved.

(ii) Trainees. Except as provided in 29 CFR 5.16, trainees will not be permitted to work at less than the predetermined rate for the work performed unless they are employed pursuant to and individually registered in a program which has received prior approval, evidenced by formal certification by the U.S. Department of Labor, Employment and Training Administration. The ratio of trainees to journeymen on the job site shall not be greater than permitted under the plan approved by the Employment and Training Administration. Every trainee must be paid at not less than the rate specified in the approved program for the trainee's level of progress, expressed as a percentage of the journeyman hourly rate specified in the applicable wage determination. Trainees shall be paid fringe benefits in accordance with the provisions of the trainee program. If the trainee program does not mention fringe benefits, trainees shall be paid the full amount of fringe benefits listed on the wage determination unless the Administrator of the Wage and Hour Division determines that there is an apprenticeship program associated with the corresponding journeyman wage rate on the wage determination which provides for less than full fringe benefits for apprentices. Any employee listed on the payroll at a trainee rate who is not registered and

participating in a training plan approved by the Employment and Training Administration shall be paid not less than the applicable wage rate on the wage determination for the work actually performed. In addition, any trainee performing work on the job site in excess of the ratio permitted under the registered program shall be paid not less than the applicable wage rate on the wage determination for the work actually performed. In the event the Employment and Training Administration withdraws approval of a training program, the contractor will no longer be permitted to utilize trainees at less than the applicable predetermined rate for the work performed until an acceptable program is approved.

(iii) Equal employment opportunity. The utilization of apprentices, trainees and journeymen under this part shall be in conformity with the equal employment opportunity requirements of Executive Order 11246, as amended, and 29 CFR Part 30.

(iv) Helpers. The permissible ratio of helpers to journeymen on a project is up to two helpers for every three journeymen. If the helper classification is specified on a contract wage determination or is approved pursuant to the conformance procedure. To ensure that this ratio does not disrupt existing established local practices in areas where wage determinations have previously contained helper classifications without any limitation on the number permitted, DOL will consider requests for variances from the ratio limitation prior to bid opening on a contract. The variance request will be approved if supported by a showing that the Davis-Bacon wage determination in effect for the type of construction in the area before the effective date of the final helper regulations contained a helper classification, and that there was a practice in the area of utilizing such helpers in excess of the two-to-three ratio on projects to which the Davis-Bacon and Related Acts applied.

5. Compliance with Copeland Act Requirements. The contractor shall comply with the requirements of 29 CFR Part 3 which are incorporated by reference in this contract.

6. Subcontracts. The contractor or subcontractor will insert in any subcontracts the clauses contained in 29 CFR 5.5(a) (1) through (10) and such other clauses as HUD or its designee may by appropriate instructions require, and also a clause requiring the subcontractors to include these clauses in any lower tier subcontracts. The prime contractor shall be responsible for the compliance by any subcontractor or lower tier subcontractor with all the contract clauses in 29 CFR Part 5.5.

7. Contracts termination; debarment. A breach of the contract clauses in 29 CFR 5.5 may be grounds for termination of the contract, and for debarment as a contractor and a subcontractor as provided in 29 CFR 5.12.

8. Compliance with Davis-Bacon and Related Act Requirements. All rulings and interpretations of the Davis-Bacon and Related Acts contained in 29 CFR Parts 1, 3, and 5 are herein incorporated by reference in this contract.

9. Disputes concerning labor standards. Disputes arising out of the labor standards provisions of this contract shall not be subject to the general disputes clause of this contract. Such disputes shall be resolved in accordance with the procedures of the Department of Labor set forth in 29 CFR Parts 5, 6, and 7. Disputes within the meaning of this clause include disputes between the contractor (or any of its subcontractors) and HUD or its designee, the U.S. Department of Labor, or the employees or their representatives.

10. (i) Certification of Eligibility. By entering into this contract, the contractor certifies that neither it (nor he or she) nor any person or firm who has an interest in the contractor's firm is a person or firm ineligible to be awarded Government contracts by virtue of Section 3(a) of the Davis-Bacon Act or 29 CFR 5.12(a) (1) or to be awarded HUD contracts or participate in HUD programs pursuant to 24 CFR Part 24.

(ii) No part of this contract shall be subcontracted to any person or firm ineligible for award of a Government contract by virtue of Section 3(a) of the Davis-Bacon Act of 29 CFR or 29 CFR 5.12(a) (1) or to be awarded HUD contracts or participate in HUD program pursuant to 24 CFR Part 24.

The penalty for making false statements is prescribed in the U.S. Criminal Code, 18 U.S.C. 1001. Additionally, U.S. Criminal Code, Section 1010, Title 18, U.S.C., "Federal Housing Administration transactions," provides in part "Whoever, for the purpose of... influencing in any way the action of such Administration... makes, utters or publishes any statement, knowing the same to be false... shall be fined not more than \$5,000 or imprisoned not more than two years, or both."

11. Complaints, Proceedings, or Testimony by Employees. No laborer or mechanic to whom the wage, salary, or other labor standards provisions of this Contract are applicable shall be discharged or in any other manner discriminated against by the Contractor or any subcontractor because such employee has filed any complaint or instituted or caused to be instituted any proceeding or has testified or is about to testify in any proceeding under or relating to the labor standards applicable under this Contract to his employer.

12. Contract Work Hours and Safety Standards Act. As used in this paragraph, the terms "laborers" and "mechanics" include watchmen and guards.

(i) **Overtime requirements.** No contractor or subcontractor contracting for any part of the contract work which may require or involved the employment of laborers, or mechanics shall require or permit any such laborer or mechanic in any workweek in which he or she is employed on such work to work in excess of forty hours in such workweek unless such laborer or mechanic receives compensation at a rate not less than one and one-half times the basic rate of pay for all hours worked in excess of forty hours in such workweek.

(ii) **Violation; liability for unpaid wages; liquidated damages.** In the event of any violation of the clause set forth in subparagraph (i) of this paragraph, the contractor and any subcontractor responsible therefore shall be liable for the unpaid wages. In addition, such contractor and subcontractor shall be liable to the United States (in the case of work done under contract for the District of Columbia or a territory, to such District or to such territory), for liquidated

damages. Such liquidated damages shall be computed with respect to each individual laborer or mechanic, including watchmen and guards, employed in violation of the clause set forth in subparagraph (i) of this paragraph, in the sum of \$10 for each calendar day on which such individual was required or permitted to work in excess of the standard workweek of forty hours without payment of the overtime wages required by the clause set forth in subparagraph (i) of this paragraph.

(iii) Withholding for unpaid wages and liquidated damages. HUD or its designee shall upon its own action or upon written request of an authorized representative of the Department of Labor withhold or cause to be withheld, from any monies payable on account or work performed by the contractor or subcontractor under any such contract or any other Federal contract with the same prime contract, or any other federally-assisted contract subject to the Contract Work Hours and Safety Standards Act, which is held by the same prime contractor such sums as may be determined to be necessary to satisfy any liabilities of such contractor or subcontractor for unpaid wages and liquidated damages as provided in the clause set forth in subparagraph (ii) of this paragraph.

(iv) Subcontracts. The contractor or subcontractor shall insert in any subcontracts the clauses set forth in subparagraph (i) through (iv) of this paragraph and also a clause requiring the subcontractors to include these clauses in any lower tier subcontracts. The prime contractor shall be responsible for compliance by any subcontractor or lower tier subcontractor with the clauses set forth in subparagraphs (i) through (iv) of this paragraph.

13. Health and Safety.

(i) No laborer or mechanic shall be required to work in surroundings or under working conditions which are unsanitary, hazardous, or dangerous to his health and safety as determined under construction safety and health standards promulgated by the Secretary of Labor by regulation.

(ii) The Contractor shall comply with all regulations issued by the Secretary of Labor pursuant to Title 29 Part 1926 (formerly part 1518) and failure to comply may result in imposition of sanctions pursuant to the Contract Work Hours and Safety Standards Act (Public Law 91-54, 83 Stat.96).

(iii) The Contractor shall include the provisions of this Article in every subcontract so that such provisions will be binding on each subcontractor. The Contractor shall take such action with respect to any subcontract as the Secretary of Housing and Urban Development or the Secretary of Labor shall direct as a means of enforcing such provisions.

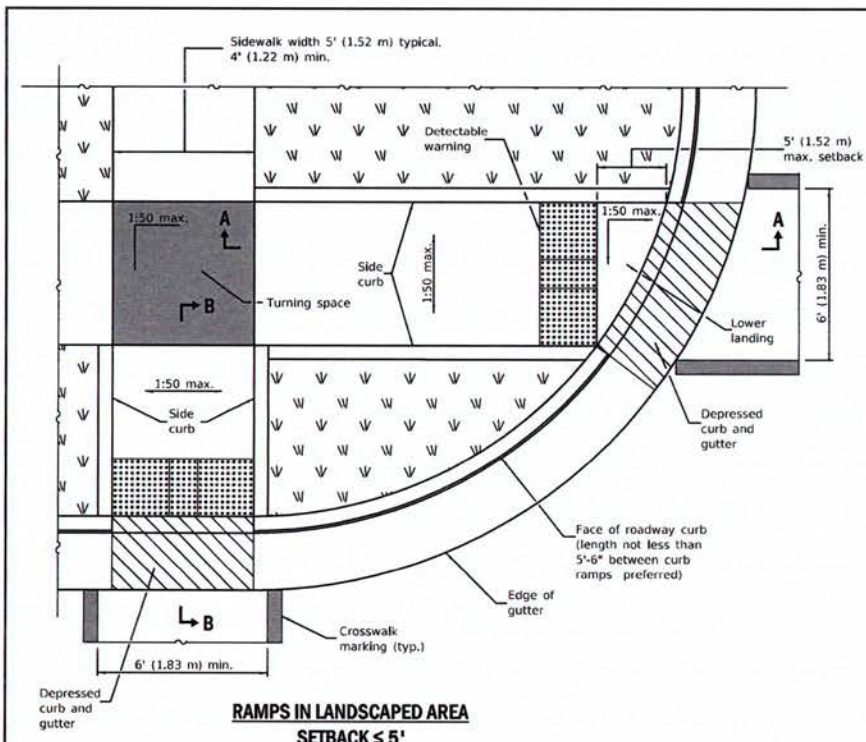

**RAMPS IN LANDSCAPED AREA
SETBACK ≤ 5'**

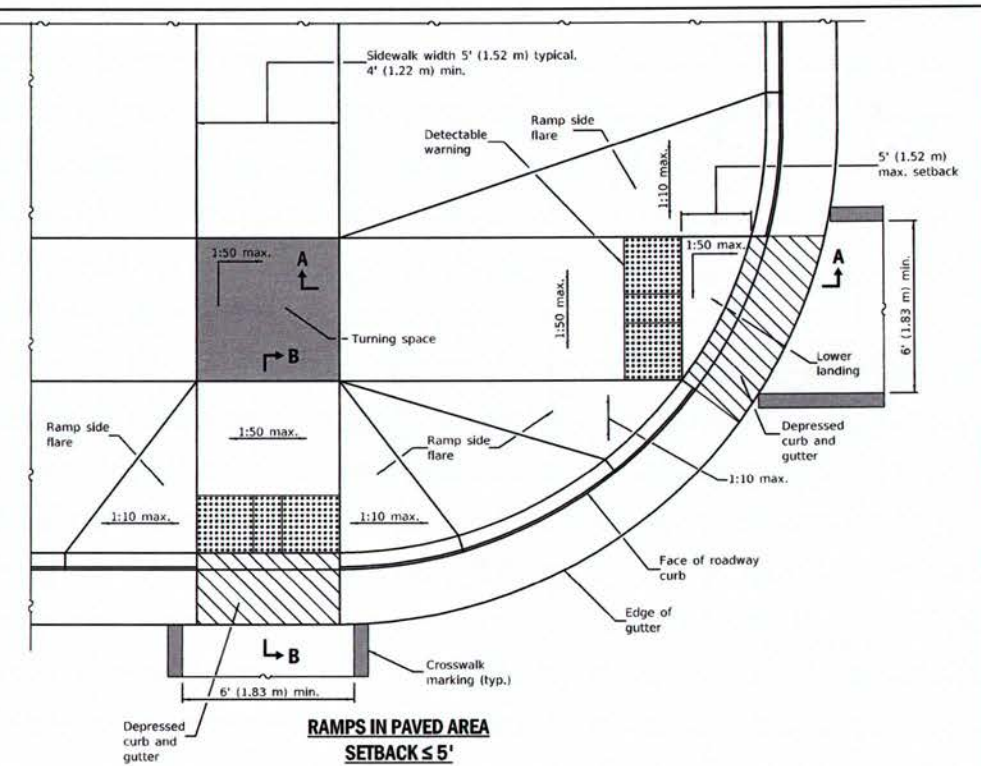

**RAMPS IN PAVED AREA
SETBACK ≤ 5'**

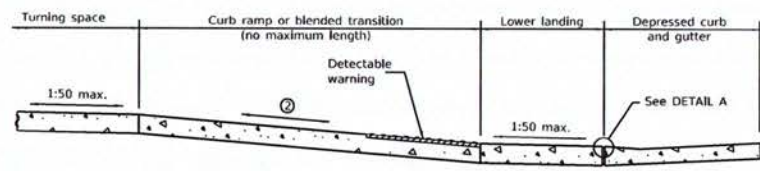

SECTION A-A

② The running slope of a curb ramp shall be 1:20 min. and 1:12 max. The running slope of a blended transition shall be 1:20 max.

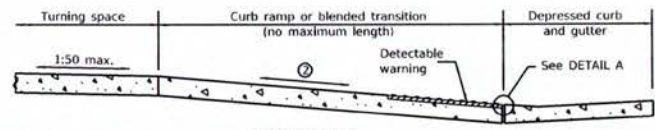

SECTION B-B

② The running slope of a curb ramp shall be 1:20 min. and 1:12 max. The running slope of a blended transition shall be 1:20 max.

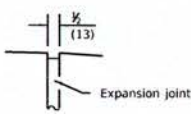

DETAIL A

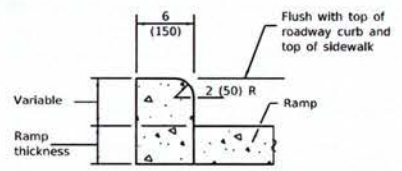

SIDE CURB DETAIL

100

See Sheet 2 for GENERAL NOTES.

PASSED	January 1, 2019
ENGINEER OF POLICY AND PROCEDURES	
APPROVED	January 3, 2019
ENGINEER OF DESIGN AND ENVIRONMENT	
ISSUED	1-6-19

DATE	REVISIONS
1-1-19	Removed "15-foot rule", added "blended transitions" and placement tolerances for detectable warnings.
1-1-18	Omitted diagonal slope at turning spaces and lower landings.

PERPENDICULAR CURB RAMPS FOR SIDEWALKS (Sheet 1 of 2)

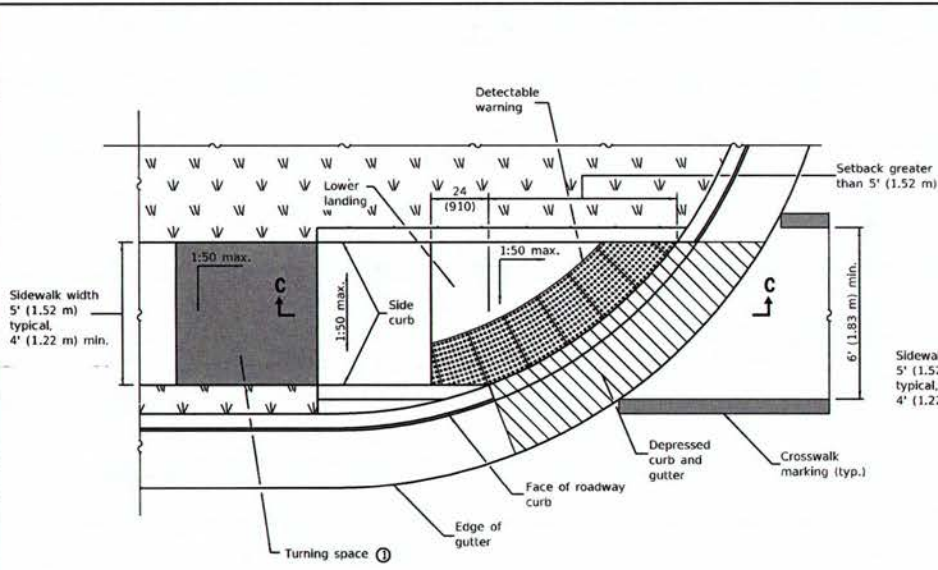

**RAMP IN LANDSCAPED AREA
SETBACK > 5'**

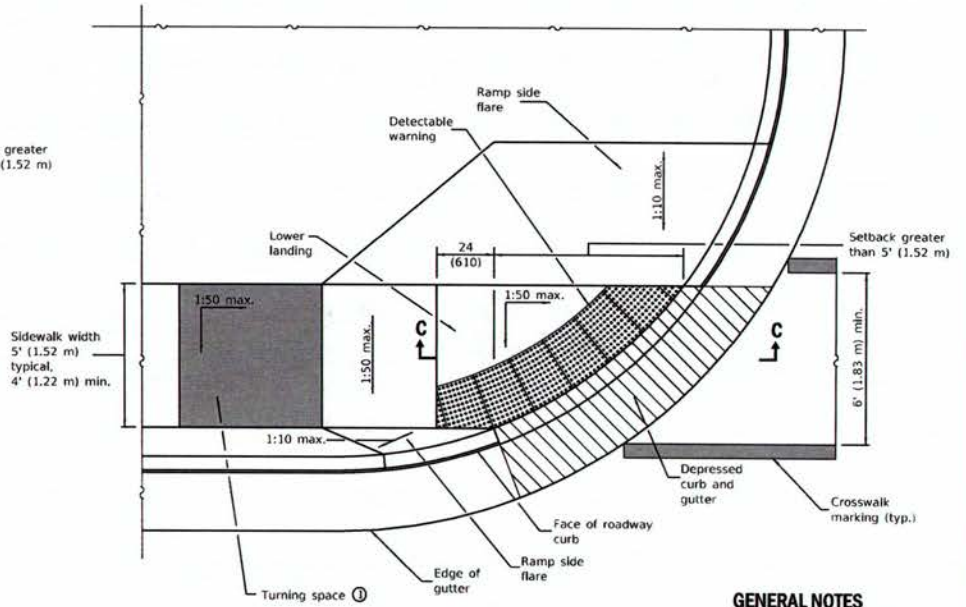

**RAMP IN PAVED AREA
SETBACK > 5'**

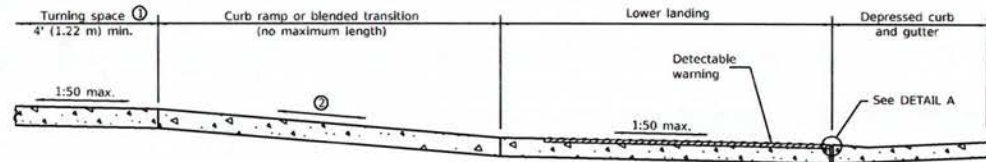

SECTION C-C

- ① This turning space not required for blended transitions.
- ② The running slope of a curb ramp shall be 1:20 min. and 1:12 max. The running slope of a blended transition shall be 1:20 max.

GENERAL NOTES

All slope ratios are expressed as units of vertical displacement to units of horizontal displacement (V:H).

Where the turning space is constrained on a side opposite a ramp, the minimum length of the turning space in the direction of the ramp-run shall be 5' (1.52 m).

Where 1:50 maximum slope is shown, 1:64 is preferred.

Detectable warnings are shown in their ideal locations but the following placement tolerances are allowed.

Side Border - Detectable warnings should extend the full width of the walking surface (excluding flared sides) but a border along each side up to 2 in. (50 mm) in width is allowed.

Curb Set-Back - Detectable warnings located at the back of curb should closely align with the curb but a gap up to 6 in. (150 mm) behind the curb is allowed.

See Standard 606001 for details of depressed curb adjacent to curb ramp.

All dimensions are in inches (millimeters) unless otherwise shown.

Illinois Department of Transportation

PASSED January 1, 2019
 ENGINEER OF POLICY AND PROCEDURES

APPROVED January 1, 2019
 ENGINEER OF DESIGN AND ENVIRONMENT

DATE: 1-8-19

**PERPENDICULAR CURB RAMPS
FOR SIDEWALKS**

(Sheet 2 of 2)

STANDARD 424001-11

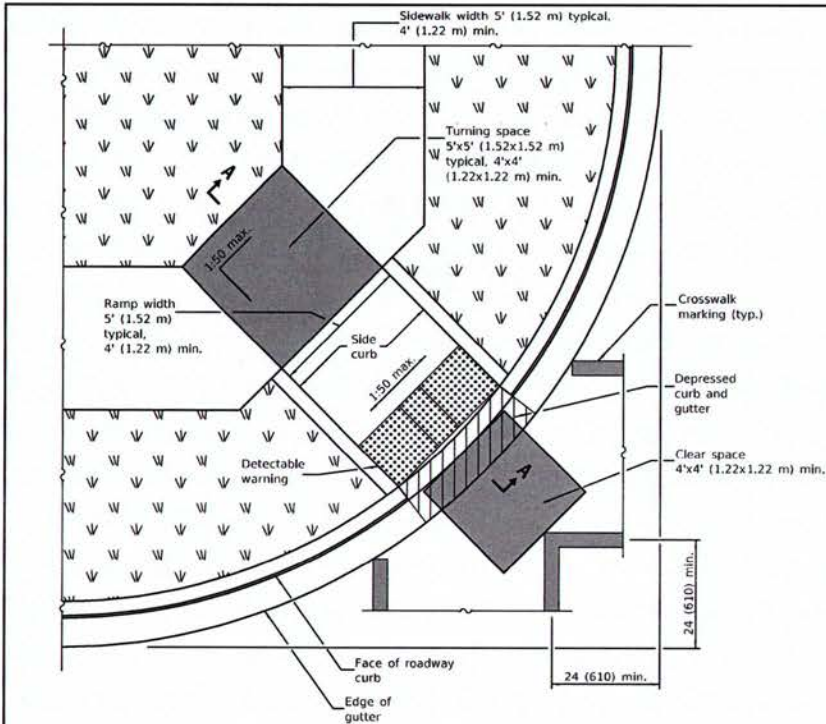

RAMP IN LANDSCAPED AREA

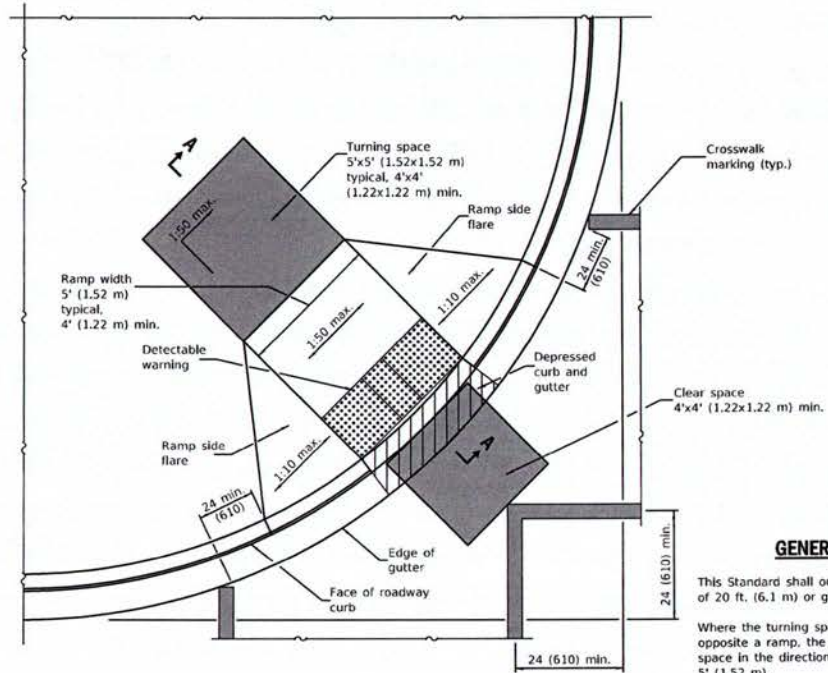

RAMP IN PAVED AREA

GENERAL NOTES

This Standard shall only be used for curb radii of 20 ft. (6.1 m) or greater.

Where the turning space is constrained on a side opposite a ramp, the minimum length of the turning space in the direction of the ramp-run shall be 5' (1.52 m).

Where 1:50 maximum slope is shown, 1:64 is preferred.

Detectable warnings are shown in their ideal locations but the following placement tolerances are allowed.

Side Border - Detectable warnings should extend the full width of the walking surface (excluding flared sides) but a border along each side up to 2 in. (50 mm) in width is allowed.

Curb Set-Back - Detectable warnings located at the back of curb should closely align with the curb but a gap up to 6 in. (150 mm) behind the curb is allowed.

All slope ratios are expressed as units of vertical displacement to units of horizontal displacement (V:H).

See Standard 606001 for details of depressed curb adjacent to curb ramp.

All dimensions are in inches (millimeters) unless otherwise shown.

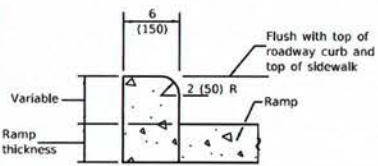

SIDE CURB DETAIL

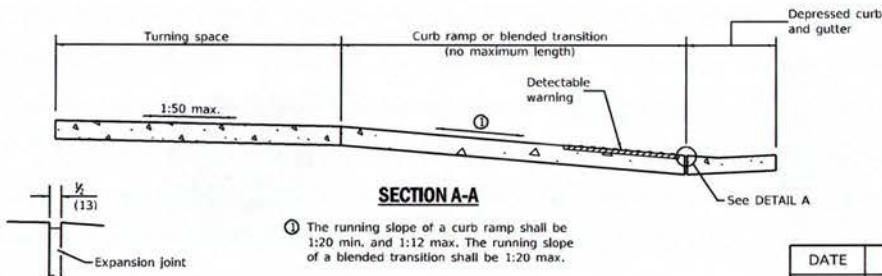

SECTION A-A

① The running slope of a curb ramp shall be 1:20 min. and 1:12 max. The running slope of a blended transition shall be 1:20 max.

DETAIL A

Illinois Department of Transportation	
PASSED	January 1, 2019
M. R. D. ENGINEER OF POLICY AND PROCEDURES	
APPROVED	January 1, 2019
S. E. C. ENGINEER OF DESIGN AND ENVIRONMENT	

DATE	REVISIONS
1-1-19	Removed "15-foot rule", added "blended transitions" and placement tolerances for detectable warnings.
1-1-18	Omitted diagonal slope at turning spaces.

DIAGONAL CURB RAMPS FOR SIDEWALKS

STANDARD 424006-04

- ② Detectable warning shall only be installed at entrances/alleys with permanent traffic control devices (i.e. stop signs, signals).
- ③ Where possible, maintain the grade of the sidewalk across the entrance/alley to avoid the need for ramps and turning spaces.

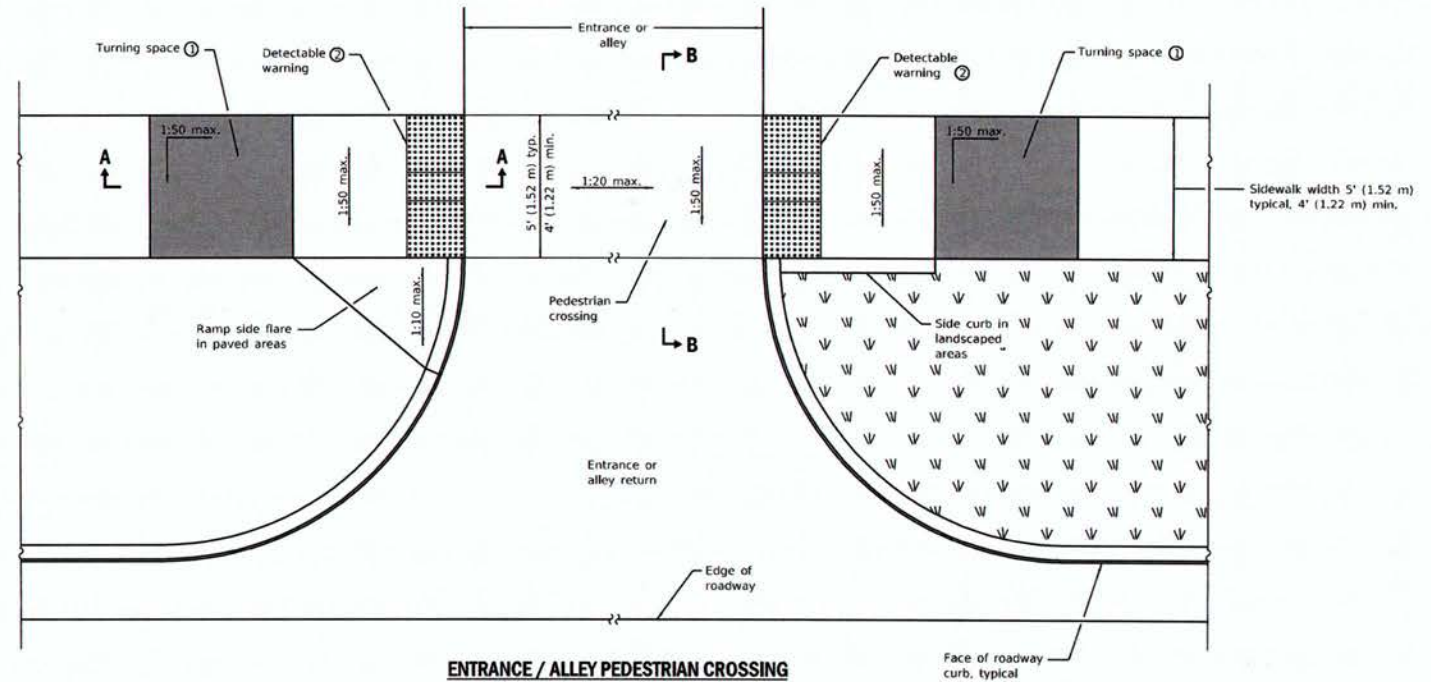

ENTRANCE / ALLEY PEDESTRIAN CROSSING

GENERAL NOTES

All slope ratios are expressed as units of vertical displacement to units of horizontal displacement (V:H).

Where 1:50 maximum slope is shown, 1:64 is preferred.

Detectable warnings are shown in their ideal locations but the following placement tolerances are allowed.

Side Border - Detectable warnings should extend the full width of the walking surface (excluding flared sides) but a border along each side up to 2 in. (50 mm) in width is allowed.

Curb Set-Back - Detectable warnings located at the back of curb should closely align with the curb but a gap up to 6 in. (150 mm) behind the curb is allowed.

All dimensions are in inches (millimeters) unless otherwise shown.

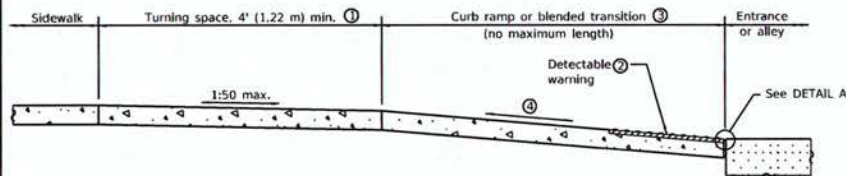

SECTION A-A

- ① Turning space not required for blended transitions.
- ③ The running slope of a curb ramp shall be 1:20 min and 1:12 max. The running slope of a blended transition shall be 1:20 max.

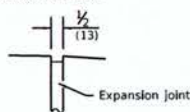

DETAIL A

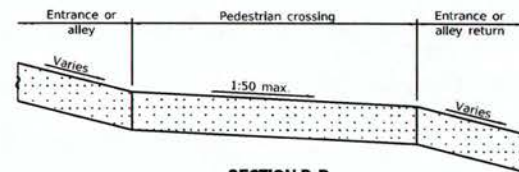

SECTION B-B

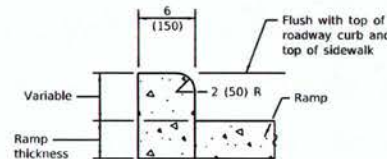

SIDE CURB DETAIL

103

Illinois Department of Transportation

PASSED *M. J. B. D.* January 1, 2019
 ENGINEER OF POLICY AND PROCEDURES

APPROVED *S. J. E. K.* January 1, 2019
 ENGINEER OF DESIGN AND ENVIRONMENT

21-117 (08/15)

DATE	REVISIONS
1-1-19	Added blended transitions and placement tolerances for detectable warnings.
1-1-18	Omitted diagonal slope at upper landings.

ENTRANCE / ALLEY PEDESTRIAN CROSSINGS

STANDARD 424026-03

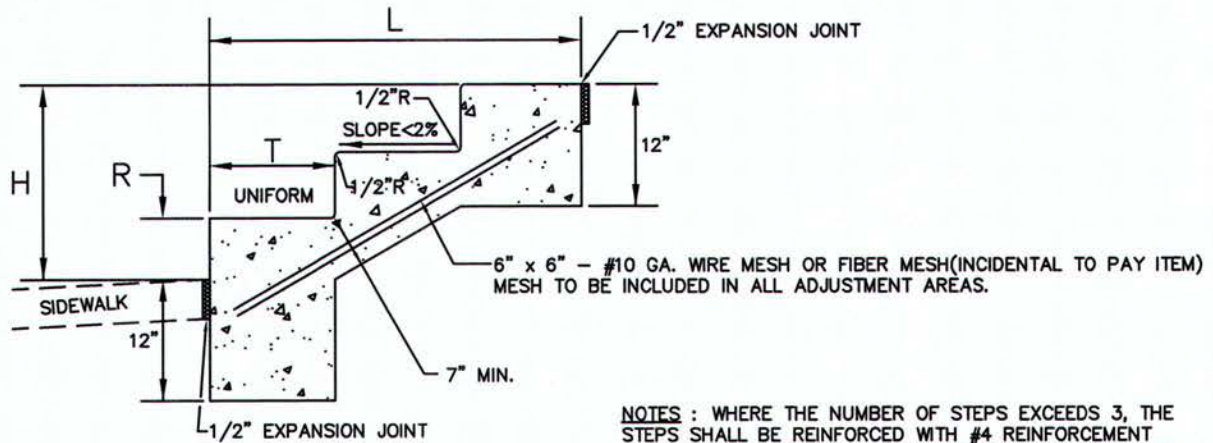

T = TREAD = 12"
 R = RISER = 4" MINIMUM TO 7" MAXIMUM
 ALL RISERS SHALL BE CONSTRUCTED TO EQUAL HEIGHT PER SET OF STEPS.

PAYMENT AREA = (L+H) x WIDTH = SQ. FT.

NOTES : WHERE THE NUMBER OF STEPS EXCEEDS 3, THE STEPS SHALL BE REINFORCED WITH #4 REINFORCEMENT BARS AT SPACINGS NOT TO EXCEED 12" COMMENCING 3" FROM THE SIDES OF THE STEPS IN ADDITION TO THE WIRE MESH REINFORCEMENT INDICATED.

THE TREADS SHALL BE FINISHED WITH A ROUGHER BROOM FINISH THAN SIDEWALKS OR DRIVEWAYS

HANDRAIL SHALL BE INSTALLED AT ITS SEPARATE UNIT PRICE FOR AREAS DETERMINED TO NEED HANDRAIL.

NOTE:
 ALL FOAM/FELT EXPANSION JOINTS SHALL BE CAULKED WITH SELF LEVELING CAULK, COVERING THE SURFACE OF THE JOINT.
 RUBBERIZED EXPANSION JOINTS ARE NOT REQUIRED TO BE CAULKED.

P.C.C. STEPS	
DRAWN BY:	BY: SML
DATE:	REVISED: 04/06/16

DESIGNER NOTES:
 THIS DRAWING SHOULD BE USED IN CONJUNCTION WITH STATE STANDARD 424001 AND DISTRICT CADD STDS.
 1. "CURB RAMPS ACCESSIBLE TO THE DISABLED" AND "COMBINATION CONCRETE CURB & SIDEWALK 4" (100mm).

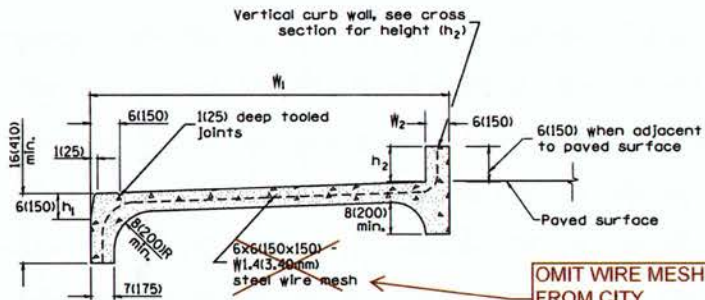

**COMBINATION CONCRETE CURB-SIDEWALK 4" (100mm)
 (SPECIAL)**

Measurement formula: $(W_1 + W_2 + h_1 + h_2) \times \text{length constructed} =$
 Payment area in square feet (square meters)

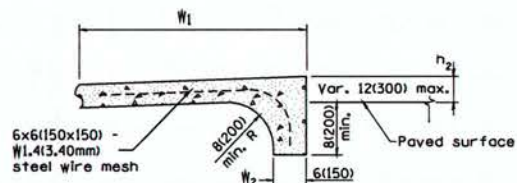
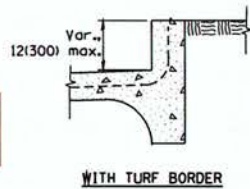

ALTERNATE BACK DETAIL
 WHEN SIDEWALK GRADE ABOVE EXISTING GRADE

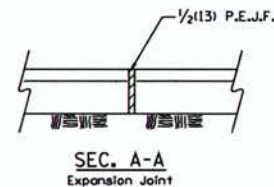
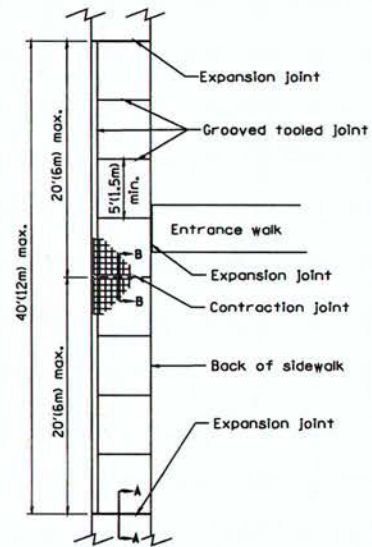

SEC. A-A
 Expansion Joint

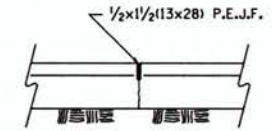

SEC. B-B
 Contraction Joint

GENERAL NOTES:

- All provisions in Section 424 of the Standard Specifications shall apply, unless otherwise shown.

All dimensions are in inches (millimeters) unless otherwise noted.

01-01-97	REVISION A-SUBS. NEW REVISION BOX	T.P.	
10-16-04	REVISED TO 2007 SPEC.	W.A.	

STATE OF ILLINOIS
 DEPARTMENT OF TRANSPORTATION

COMBINATION CONCRETE CURB-SIDEWALK 4" (100mm), (SPECIAL)
 NOT TO SCALE

CADD STD. 424106-D4

S.A. SHEET	SECTION	COUNTY	TOTAL SHEETS	SHEET NO.
				CONTRACT NO.

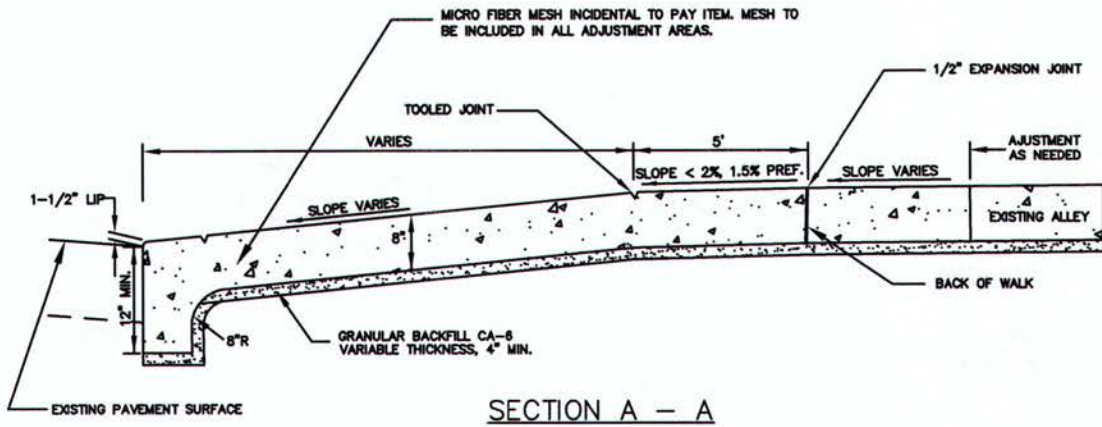

SECTION A - A

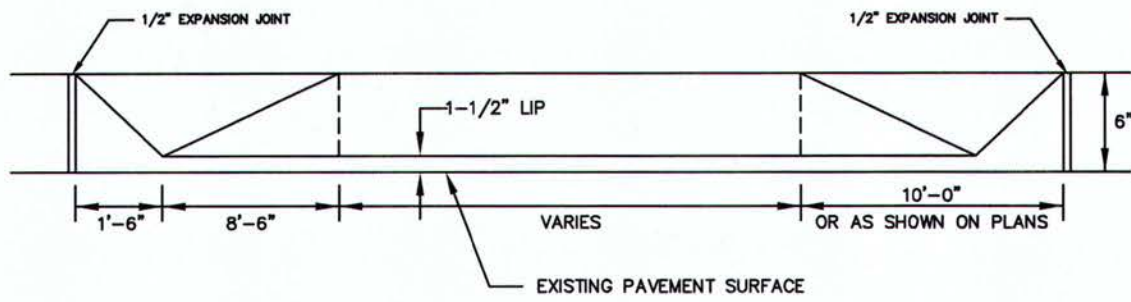

CURB LINE PROFILE

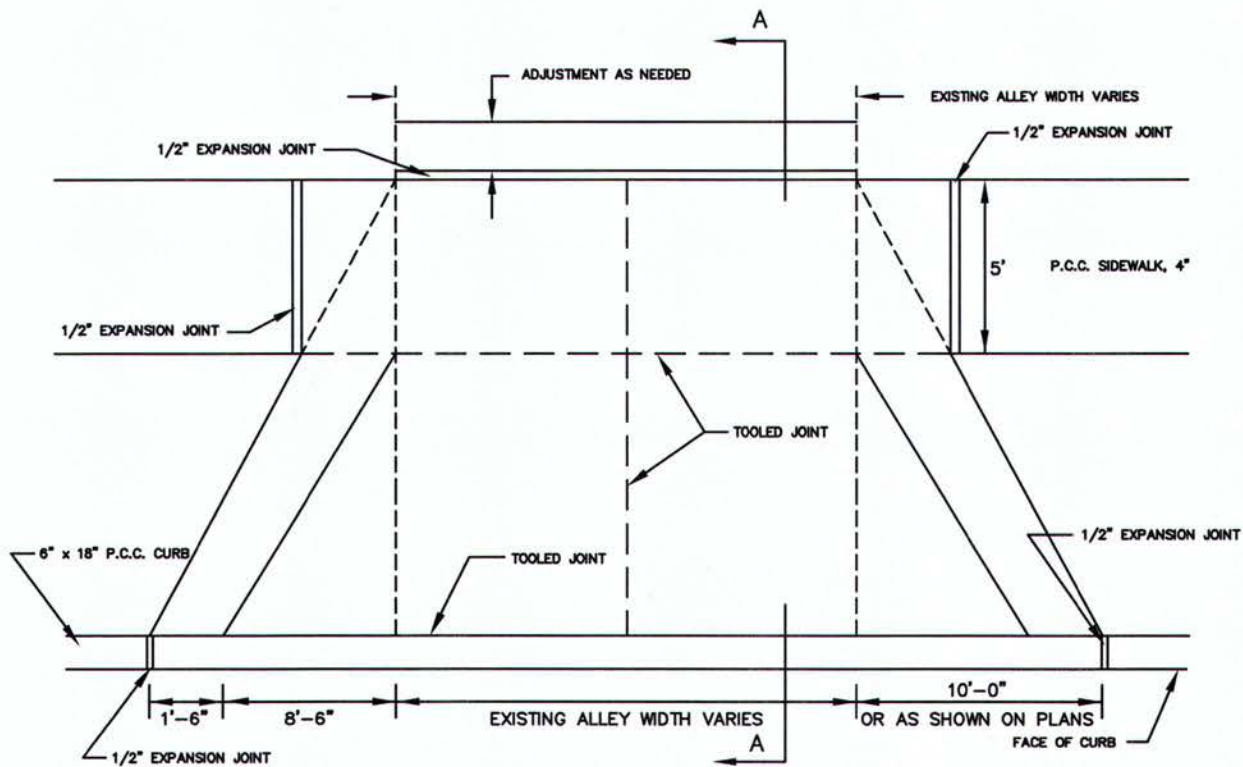

P.C.C. COMMERCIAL DRIVEWAY/ALLEY APPROACH, 8"
ADJACENT TO PROPERTY LINE SIDEWALK

NOTE:
ALL FOAM/FELT EXPANSION JOINTS SHALL BE CAULKED WITH SELF LEVELING CAULK, COVERING THE SURFACE OF THE JOINT.
RUBBERIZED EXPANSION JOINTS ARE NOT REQUIRED TO BE CAULKED.
IF A COMBINATION CURB & GUTTER IS INSTALLED PRIOR TO THE DRIVEWAY APPROACH, THEN AN EXPANSION JOINT SHALL BE PLACED BETWEEN THE BACK OF CURB AND THE PROPOSED DRIVEWAY APPROACH.



CITY OF PEORIA

PUBLIC WORKS DEPT. - ENGINEERING DIV.

P.C.C. COMMERCIAL DRIVEWAY/ALLEY APPROACH, 8"

DRAWN BY:

BY: SML

DATE:

REVISED: 04/06/16

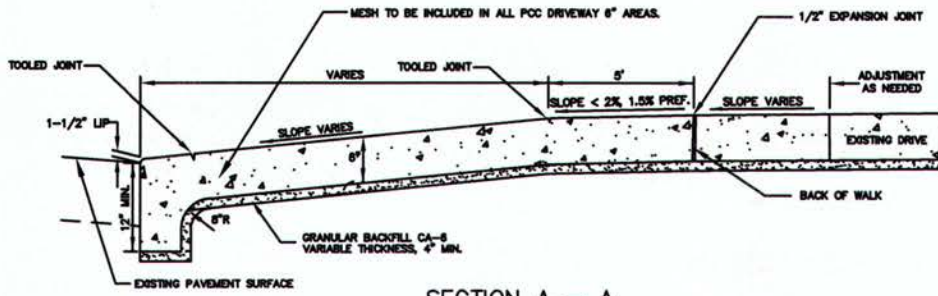

SECTION A - A

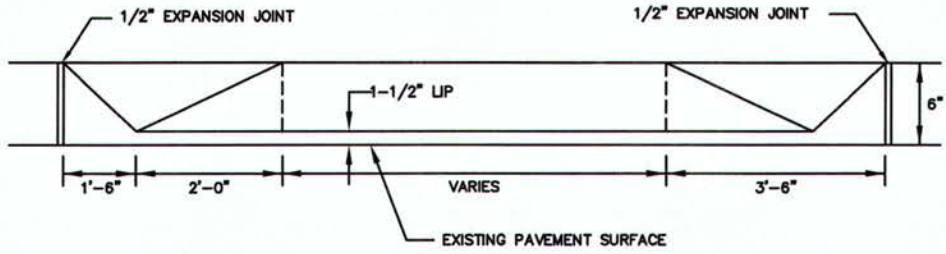

CURB LINE PROFILE

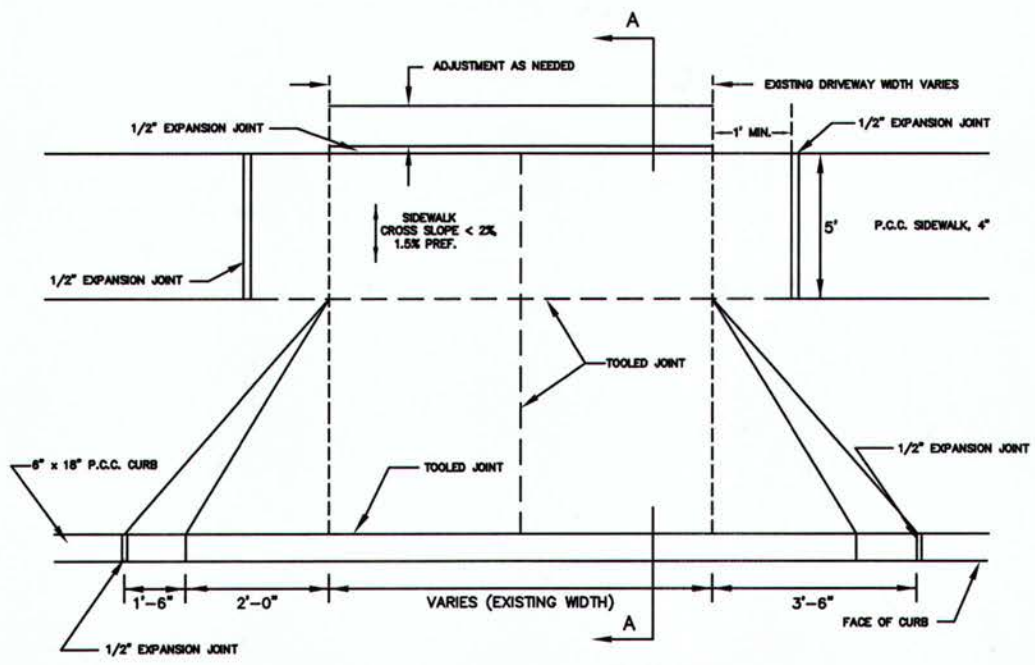

P.C.C. DRIVEWAY PAVEMENT, 6"
ADJACENT TO PROPERTY LINE SIDEWALK

NOTE:
ALL FOAM/FELT EXPANSION JOINTS SHALL BE CAULKED WITH SELF LEVELING CAULK, COVERING THE SURFACE OF THE JOINT.
RUBBERIZED EXPANSION JOINTS ARE NOT REQUIRED TO BE CAULKED.

IF A COMBINATION CURB & GUTTER IS INSTALLED PRIOR TO THE DRIVEWAY APPROACH, THEN AN EXPANSION JOINT SHALL BE PLACED BETWEEN THE BACK OF CURB AND THE PROPOSED DRIVEWAY APPROACH.

P.C.C. DRIVEWAY PAVEMENT	
DRAWN BY:	BY: SML
DATE:	REVISED: 10/04/16